

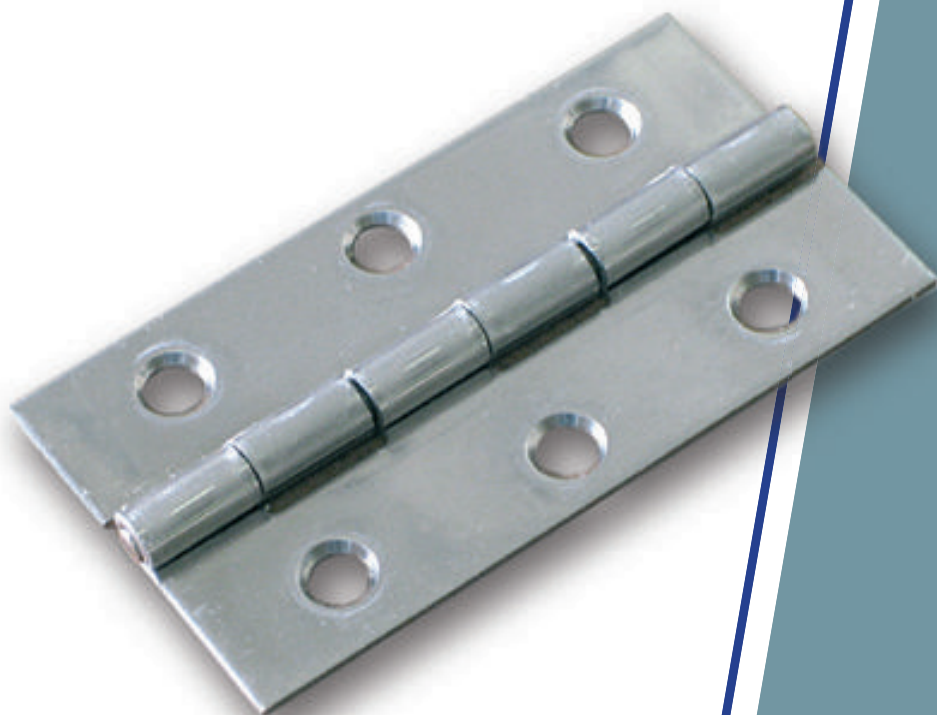































STAINLESS STEEL RANGE



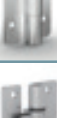

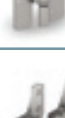

























HINGES













		Undrilled continuous hinge with one cranked leaf	349
		Rolled knuckle continuous hinge - 20 mm width	344
NEW		Rolled knuckle continuous hinge - 25 mm width	344
NEW		Rolled knuckle continuous hinge - 30 mm width	344
		Rolled knuckle continuous hinge - 32 mm width	345
NEW		Rolled knuckle continuous hinge - 40 mm width	345
NEW		Rolled knuckle continuous hinge - 50 mm width	346
		Rolled knuckle continuous hinge - 57 mm width	346
NEW		Rolled knuckle continuous hinge - 60 mm width	346
		Rolled knuckle continuous hinge - 63 mm width	347
		Rolled knuckle continuous hinge - 70 mm width	347
		Rolled knuckle continuous hinge - 76 mm width	347
NEW		Rolled knuckle continuous hinge - 80 mm width	348
		Rolled knuckle continuous hinge - 100 mm width	348
		Rolled knuckle continuous hinge - 120 mm width	348
		Drilled continuous hinge with one cranked leaf	349
		Continuous hinge with two cranked leaves	350
		Rolled knuckle continuous hinge "Imperial" dimension	350
		Concealed hinges A - 120° opening	351
		Concealed hinges B - 120° opening	351
		Concealed hinges with retractable pin	352
		Concealed pin hinges - 100° opening	352
		Concealed pin hinges - 120° opening	353
		Concealed hinge with friction - 90° opening	353
NEW		Concealed hinges with spring - 95° opening	354
NEW		Concealed hinges without spring - 95° opening	354
		Concealed hinge - 180° opening	355
		Concealed heavy duty hinge for flush doors - 90° opening	355
		Concealed heavy duty hinge for flush doors - 90° opening	356
		Concealed heavy duty hinge for flush doors - 90° opening	356
		Concealed springloaded pin hinges A	357

	Concealed springloaded pin hinges B	357
NEW 	Concealed hinges - 90° opening	358
NEW 	Concealed hinges - 125° opening	359
	Spring loaded concealed hinges - 90° opening	360
	Spring loaded concealed hinges - 150° opening	360
NEW 	Concealed hinges with two cranked leaves - undrilled - 120° opening - version A	361
NEW 	Concealed hinges with two cranked leaves - drilled - 120° opening - version A	361
NEW 	Concealed hinges with two cranked leaves - undrilled - 120° opening - version B	362
NEW 	Concealed hinges with two cranked leaves - drilled - 120° opening - version B	362
	Opening spring hinges 120 mm long	363
	Closing spring hinges 120 mm long	363
	Opening spring hinges 180 mm long	364
	Closing spring hinges 180 mm long	364
	Opening spring hinges 240 mm long	365
	Closing spring hinges 240 mm long	365
	Spring hinges 50 mm long	366

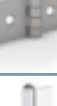

	Spring hinge 60 mm long - with 4 holes	366
	Spring hinges 75 mm long - drilled	367
	Spring hinges 75 mm long - undrilled	367
	Spring hinges 80 mm long	368
	Spring hinges 160 mm long	368
	Spring hinges 170 mm long	369
	Cranked spring hinge 66 mm long	369
	Cranked spring hinge 60 mm long	370
NEW 	Lift-off rising hinge in stainless steel	370
NEW 	Friction hinge in stainless steel - friction torque 3 N.m	371
NEW 	Friction hinge in stainless steel - friction torque 5 N.m	371
	Stainless steel friction hinge - friction torque 1.9 N.m	372
	Stainless steel friction hinge - friction torque 5.8 N.m	372
	Dual axis torque hinge - 30 x 60 mm	373
	Dual axis torque hinge - 50 x 76 mm	374
NEW 	Swivel torque hinge - torque 2 N.m	375

NEW		Swivel torque hinge with hole diameter 21.5 mm - torque 5 N.m	375		Headed pin BT for Modulo system	383
NEW		Swivel torque hinge with hole diameter 34 mm - torque 7 N.m	376		Plug (VA) for Modulo system	383
		Hinge with stop at 115°	376		Heavy duty hinges - 65 x 230 mm	384
		Hinge with stop at 60°	377		Flat top weld-on stainless steel hinges - stainless steel pin - brass washer	384
		Soft-close dampening hinge in stainless steel	378		Square hinges with two offset leaves and removable pin - with 4 holes	385
NEW		Forged hinges - 3 knuckles	379		Square hinges with two offset leaves and removable pin - with 6 holes	385
		Forged hinges with reversed leaves - 3 knuckles	379		Square hinges with two offset leaves and riveted pin - with 4 holes	386
NEW		Forged hinges - 5 knuckles	380		Square hinges with two offset leaves and riveted pin - with 6 holes	386
		Heavy duty pin hinges	380		Square hinges with no offset leaf and riveted pin - no holes	387
		Half leaves for Modulo hinges - thickness 3 mm	381		Square hinges with no offset leaf and riveted pin - with 4 holes	387
		Half leaves for Modulo hinges - thickness 4 mm	381		Square hinges with no offset leaf and riveted pin - with 6 holes	388
		Half leaves for Modulo hinges - thickness 5 mm	381		Hinge 30 x 30 mm	388
		Half leaves for Modulo pin hinges - thickness 3 mm	382		Hinge with nylon washers	389
		Half leaves for Modulo pin hinges - thickness 4 mm	382		Hinge 50 x 30 mm	389
		Half leaves for Modulo pin hinges - thickness 5 mm	382		Hinges 50 x 40 mm	390
		Expanded pin BG for Modulo system	383		Hinges 60 x 35 mm	390



















	Hinge 75 x 40 mm	391
	Lift-off hinges 80 x 60 mm - stainless steel	391
	Lift-off hinges 80 x 80 mm - stainless steel with 6 holes	392
	Lift-off hinges 100 x 82 mm - stainless steel with 8 holes	392
	Hinge for marine applications - 36.5 x 38 mm	393
	Hinge for marine applications - 36.5 x 56.5 mm	393
	Hinge for marine applications - 36.5 x 76 mm	394
	Hinges for marine applications - 36.5 x 65.5 mm	394
	Hinge for marine applications - 38.1 x 71.1 mm	395
	Hinge for marine applications - 52 x 70 mm	395
	Hinge for marine applications - 30 x 101 mm	396
	Hinge for marine applications - 38 x 178 mm	396
	Hinge for marine applications - 40.1 x 137.3 mm	397
	Small butt hinges with one cranked leaf 38 mm	397
	Small butt hinge with one cranked leaf 50 mm	398
	Small butt hinge with one cranked leaf and removable pin 50 mm	398

	Small butt hinge with one cranked leaf 60 mm	399
	Small butt hinge with one cranked leaf 66 mm	399
	Pin hinge with one cranked leaf	400
	Stainless steel hinge with removable pin	400
	Removable pin hinges with nylon washers	401
	Hinges 62 x 74 mm	401
	Hinge 20 x 65 mm	402
	Flag hinge without washer with two offset leaves	402
	Flag hinge with washer with two offset leaves	403
NEW 	Flag hinge without washer - drilled - flat knuckle	403
NEW 	Glass door hinge in brushed stainless steel	404
	Glass door hinge in stainless steel	404

LATCHING SYSTEMS

NEW 	Slam latch in stainless steel - bolt "nose-up"	405
NEW 	Slam latch in stainless steel - bolt "nose-down"	405
	Springloaded bolt - reversible bolt	406





	Paddle latches 68.5 x 84 mm	406		Padlockable rotary toggle latches	416
	Concealed springloaded pin hinges A	407		Lockable toggle latch without strike	416
	Concealed springloaded pin hinges B	407		Strike for part number 16-1-4257	417
NEW 	Springloaded bolt with locking system B	408		Toggle latches without strike - 50 mm	417
	Push barrel bolt	408		Strikes for part numbers 16-7-3525 and 16-7-3527	418
	Budget latch - square 6x6 - stainless steel	409		Toggle latches with strike - 52 mm	418
	Budget latches - square 8x8	409		Toggle latch without strike - 58.1 mm	419
	Spring budget latch	410		Strike for part number 16-7-3876	419
	Strike for spring budget latch 16-1-4031	410		Toggle latch without strike - 80.2 mm	420
	Barrel bolt in stainless steel	411		Strike for part number 16-7-3526	420
NEW 	Stainless steel dual ball catches	412		Toggle latches without strike - 88.5 mm	421
NEW 	Compact magnetic catch	413		Strike for part number 16-7-3829	421
NEW 	Screw-on magnetic catch without counter plate - force 14 kg	413		Other strike for part number 16-7-3829	422
NEW 	Screw-on magnetic catch without counter plate - force 7 and 14 kg - high temperature resistance	414		Toggle latch without strike (consistent tension)	423
	Rotary toggle latches	415		Strike for part number 16-7-3891	423
	Spring loaded rotary toggle latches	415		Padlockable toggle latch - 80.2 mm	424

	Strike for part number 16-7-3724	424		Spring loaded toggle latch without strike - with push button	432
	Padlockable toggle latch - 97.6 mm	425		Strike for part numbers 16-7-3911, 16-7-3918 and 16-7-3920	432
	Strike for part number 16-7-3884	425		Spring loaded toggle latch without strike - 52 mm	433
	Spring loaded and padlockable toggle latch - 52 mm	426		Strikes for part number 16-7-3736	433
	Strikes for part number 16-7-3760	426		Spring loaded toggle latches without strike - 74 mm	434
	Spring loaded and padlockable toggle latch - 74 mm	427		Strikes for part numbers 16-7-3745 and 16-7-3748	434
	Strikes for part number 16-7-3766	427		Adjustable toggle latch with secondary lock and strike	435
	Spring loaded and padlockable toggle latch - 70.9 mm	428		Adjustable toggle latch without strike 70.6 mm	436
	Strike for part number 16-7-3917	428		Strike for part number 16-7-3933	436
	Adjustable toggle latch - padlockable - 70.6 mm	429		Adjustable toggle latches with strike 82 mm and 103 mm long	437
	Strike for part number 16-7-3938	429		Adjustable toggle latch with strike 118 mm	437
	Adjustable toggle latches with strike - padlockable - 82 mm to 118 mm	430		Adjustable toggle latch with strike 88 mm	438
	Adjustable toggle latch with strike - padlockable - 174 mm	430		Adjustable toggle latch with strike 138 mm	438
	Spring loaded toggle latch without strike 35.8 mm	431		Adjustable toggle latch with secondary lock without strike	439
	Strike for part number 16-7-3906	431		Strike for part number 16-1-4231	439
	Spring loaded toggle latches without strike - 70.8 mm	432		Other strikes for part number 16-1-4231	440

	Toggle latch without strike 62.5 mm	440
	Toggle latch without strike - 64 mm	441
	Toggle latch without strike - 67.6 mm	441
	Toggle latch without strike - 93.2 mm	442
NEW 	Hooked toggle latch without strike	442
	Alternative strike for toggle latches	443







HANDLES

	Front mounted grab handle 88 mm	444
	Front mounted grab handles 107 mm in steel or stainless steel	444
	Front mounted grab handles 106 and 126 mm	445
	Rear mounted grab handles 110 mm	445
	Rear mounted grab handles 95 to 150 mm	446
	Rear mounted grab handles 92 to 200 mm	446
	Drop handle with chamfered angles - load 35 kg	447
	Spring loaded handles - load 34 kg - 180° opening	447
	Spring loaded handles 130.3 mm - load 45 kg	448

	Spring loaded handle 130 mm - load 54 kg	448
NEW 	Retractable flush handles in stainless steel	449
	Bolt-on flush handle 120 x 60 mm	449
	Bolt-on flush handle 120 x 62 mm	450
NEW 	Bolt-on flush handle 138 x 88 mm	450

ACCESSORIES

	Support stays with automatic release - small size	451
	Support stays with automatic release in stainless steel	451
	Support stays with manual release	452
	Bracket	452
	Multi-angle lid stay with lock	453
	Support stay	453
	Heavy duty spring loaded stay	454
	Stay with safety stop	455
	Stays without bracket	455
NEW 	Folding bracket	456

	Door holders	457
	3/4 extension ball-bearing slide (2 pieces), front disconnect	458
	Full extension ball-bearing slide (3 pieces), front disconnect and positive lock	459
	Full extension ball-bearing slide (3 pieces), front disconnect and positive stop	460
	Heavy duty, full extension ball-bearing slide (3 pieces), front disconnect and positive stop	461
NEW 	Full extension ball-bearing slide (3 pieces), soft-closing	462



Stainless steel range - Hinges

Continuous hinges

Rolled knuckle continuous hinge - 20 mm width

Opening angle 270°. Other lengths and pin materials are available on request.
Specific drilling requirements are also available on request.



Part number	Material	Finish	A	B	C	D	E	F	G	S	Pin material	Note	Weight (g)
42-1-3664	304 stainless steel	raw	2040	20	0.8	2	15				stainless steel	undrilled	320
42-1-4195	304 stainless steel	raw	2040	20	0.8	2	15	11.5	60	2.8	stainless steel	drilled	310



Rolled knuckle continuous hinge - 25 mm width

Opening angle 270°. Other lengths and pin materials are available on request.
Specific drilling requirements are also available on request.



Part number	Material	Finish	A	B	C	D	E	F	G	S	Pin material	Note	Weight (g)
NEW 42-1-3910	304 stainless steel	raw	1020	25	0.8	2	15				stainless steel	undrilled	224
42-1-3767	304 stainless steel	raw	2040	25	0.8	2	15				stainless steel	undrilled	448
42-1-4196	304 stainless steel	raw	2040	25	0.8	2	15	14	60	3.6	stainless steel	drilled	420
42-1-4096	304 stainless steel	raw	1800	25	1	2	15				stainless steel	undrilled	500
42-1-3949	304 stainless steel	raw	2040	25	1	2	15				stainless steel	undrilled	558
NEW 42-1-4546	316L stainless steel	raw	1980	25	0.8	2	15				stainless steel	undrilled	385



Rolled knuckle continuous hinge - 30 mm width

Opening angle 270°. Other lengths and pin materials are available on request.
Specific drilling requirements are also available on request.



Part number	Material	Finish	A	B	C	D	E	F	G	S	Pin material	Note	Weight (g)
NEW 42-1-3909	304 stainless steel	raw	1020	30	0.8	2	15				stainless steel	undrilled	255
42-1-3580	304 stainless steel	raw	2040	30	0.8	2	15				stainless steel	undrilled	510
42-1-4089	304 stainless steel	raw	1800	30	1	2	15				stainless steel	undrilled	500
42-1-3300	304 stainless steel	raw	2040	30	1	2	15				stainless steel	undrilled	670
42-1-4197	304 stainless steel	raw	2040	30	1	2	15	16.8	60	3.9	stainless steel	drilled	640
42-1-3950	304 stainless steel	raw	1995	30	1.5	4	30				stainless steel	undrilled	1283
42-1-3948	304 stainless steel	raw	2000	30	2	6	25				stainless steel	undrilled	1800
NEW 42-1-4082	316L stainless steel	raw	1020	30	1	2	15				stainless steel	undrilled	335
42-1-4000	316L stainless steel	raw	2040	30	1	2	15				stainless steel	undrilled	670

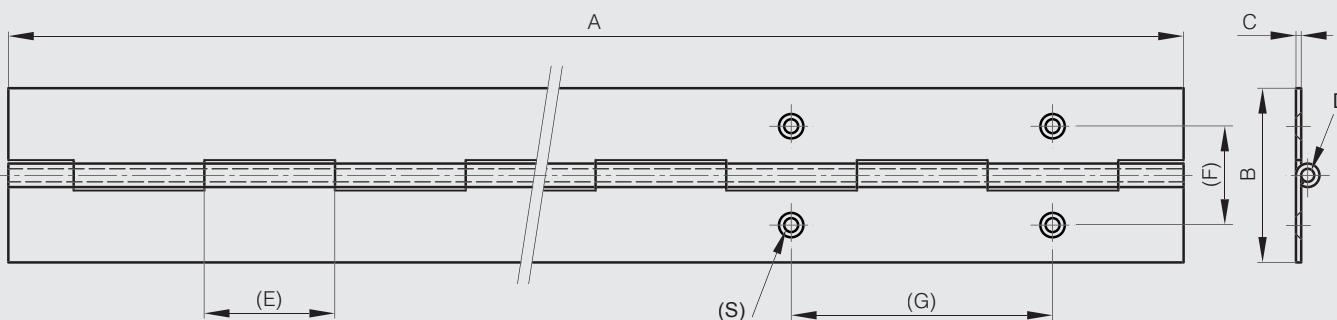



Rolled knuckle continuous hinge - 32 mm width

Opening angle 270°. Other lengths and pin materials are available on request.
Specific drilling requirements are also available on request.



Part number	Material	Finish	A	B	C	D	E	Pin material	Note	Weight (g)
42-1-4346	304 stainless steel	raw	1800	32	1.2	3	30	stainless steel	undrilled	790
42-1-4460	304 stainless steel	raw	1950	32	1.5	3	12.5	stainless steel	undrilled	1030



Rolled knuckle continuous hinge - 40 mm width

Opening angle 270°. Other lengths and pin materials are available on request.
Specific drilling requirements are also available on request.



Part number	Material	Finish	A	B	C	D	E	F	G	S	Pin material	Note	Weight (g)
NEW 42-1-4257	304 stainless steel	raw	1020	40	1.2	3	30				stainless steel	undrilled	500
42-1-4347	304 stainless steel	raw	1800	40	1.2	3	30				stainless steel	undrilled	940
42-1-4350	304 stainless steel	raw	2040	40	1.2	3	30				stainless steel	undrilled	1000
42-1-4349	304 stainless steel	raw	2040	40	1.2	3	30	22.7	60	4.2	stainless steel	drilled	1000
42-1-4461	304 stainless steel	raw	1950	40	1.5	3	12.5				stainless steel	undrilled	1230
42-1-3301	304 stainless steel	raw	2040	40	1.5	4	15				stainless steel	undrilled	1400
42-1-4199	304 stainless steel	raw	2040	40	1.5	4	15	22.7	60	4	stainless steel	drilled	1400
42-1-3770	304 stainless steel	raw	2040	44	2	6	30				stainless steel	undrilled	2463
NEW 42-1-4083	316L stainless steel	raw	1020	40	1.5	4	15				stainless steel	undrilled	700
42-1-4001	316L stainless steel	raw	2040	40	1.5	4	15				stainless steel	undrilled	1400
42-1-3665	430 stainless steel	raw	2040	40	0.8	2	15				stainless steel	undrilled	650

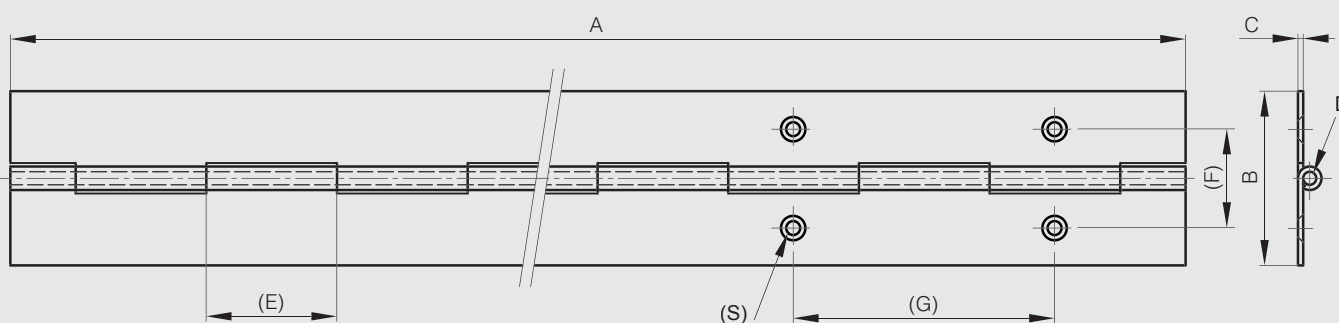



Continuous hinges

Rolled knuckle continuous hinge - 50 mm width



Opening angle 270°. Other lengths and pin materials are available on request.
Specific drilling requirements are also available on request.

	Part number	Material	Finish	A	B	C	D	E	F	G	S	Pin material	Note	Weight (g)
NEW	42-1-4258	304 stainless steel	raw	1020	50	1.2	3	30				stainless steel	undrilled	650
	42-1-4348	304 stainless steel	raw	1800	50	1.2	3	30				stainless steel	undrilled	1100
	42-1-4353	304 stainless steel	raw	2040	50	1.2	3	30				stainless steel	undrilled	1300
	42-1-4352	304 stainless steel	raw	2040	50	1.2	3	30	28	60	4	stainless steel	drilled	1270
	42-1-4462	304 stainless steel	raw	1950	50	1.5	3	12.5				stainless steel	undrilled	1450
	42-1-4219	304 stainless steel	raw	1800	50	1.5	4	15				stainless steel	undrilled	1500
	42-1-3918	304 stainless steel	raw	2000	50	2	4	25				stainless steel	undrilled	2350
NEW	42-1-4259	316L stainless steel	raw	1020	50	1.2	3	20				stainless steel	undrilled	655
	42-1-4354	316L stainless steel	raw	2040	50	1.2	3	30				stainless steel	undrilled	1310



Rolled knuckle continuous hinge - 57 mm width



Opening angle 270°. Other lengths and pin materials are available on request.
Specific drilling requirements are also available on request.

	Part number	Material	Finish	A	B	C	D	E	Pin material	Note	Weight (g)
	42-1-4220	304 stainless steel	raw	2160	57	1.5	4	15	stainless steel	undrilled	2000



Rolled knuckle continuous hinge - 60 mm width



Opening angle 270°. Other lengths and pin materials are available on request.
Specific drilling requirements are also available on request.

	Part number	Material	Finish	A	B	C	D	E	F	G	S	Pin material	Note	Weight (g)
NEW	42-1-4086	304 stainless steel	raw	1020	60	2	6	30				stainless steel	undrilled	1400
	42-1-3302	304 stainless steel	raw	2040	60	2	6	30				stainless steel	undrilled	2800
	42-1-4201	304 stainless steel	raw	2040	60	2	6	30	35	60	4	stainless steel	drilled	2800
NEW	42-1-4085	316L stainless steel	raw	1020	60	2	6	30				stainless steel	undrilled	1400
	42-1-4002	316L stainless steel	raw	2040	60	2	6	30				stainless steel	undrilled	2800

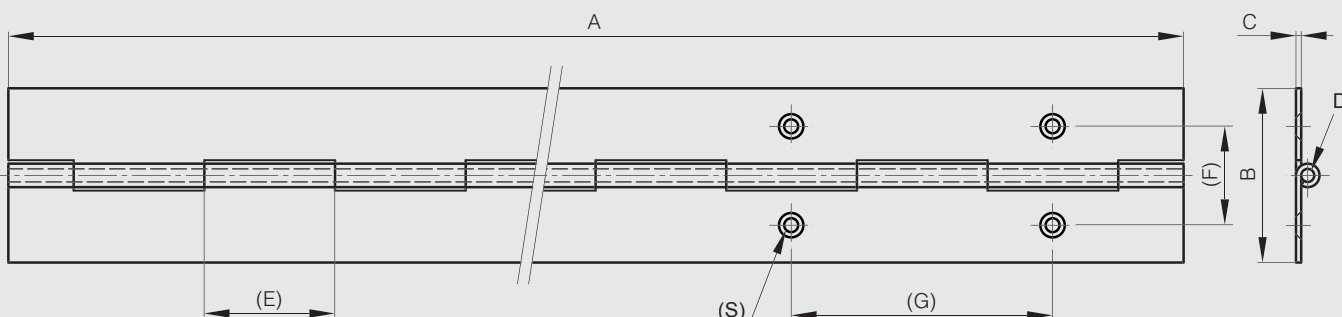



Rolled knuckle continuous hinge - 63 mm width

Opening angle 270°. Other lengths and pin materials are available on request.
Specific drilling requirements are also available on request.



Part number	Material	Finish	A	B	C	D	E	Pin material	Note	Weight (g)
42-1-4221	304 stainless steel	raw	1800	63	1.5	4	15	stainless steel	undrilled	1800



Rolled knuckle continuous hinge - 70 mm width

Opening angle 270°. Other lengths and pin materials are available on request.
Specific drilling requirements are also available on request.



Part number	Material	Finish	A	B	C	D	E	Pin material	Note	Weight (g)
42-1-4097	304 stainless steel	raw	1800	70	1.5	4	15	stainless steel	undrilled	1900
42-1-3859	304 stainless steel	raw	2040	70	2	6	30	stainless steel	undrilled	3120



Rolled knuckle continuous hinge - 76 mm width

Opening angle 270°. Other lengths and pin materials are available on request.
Specific drilling requirements are also available on request.



Part number	Material	Finish	A	B	C	D	E	Pin material	Note	Weight (g)
42-1-4094	304 stainless steel	raw	2160	76	1.5	4	15	stainless steel	undrilled	2400

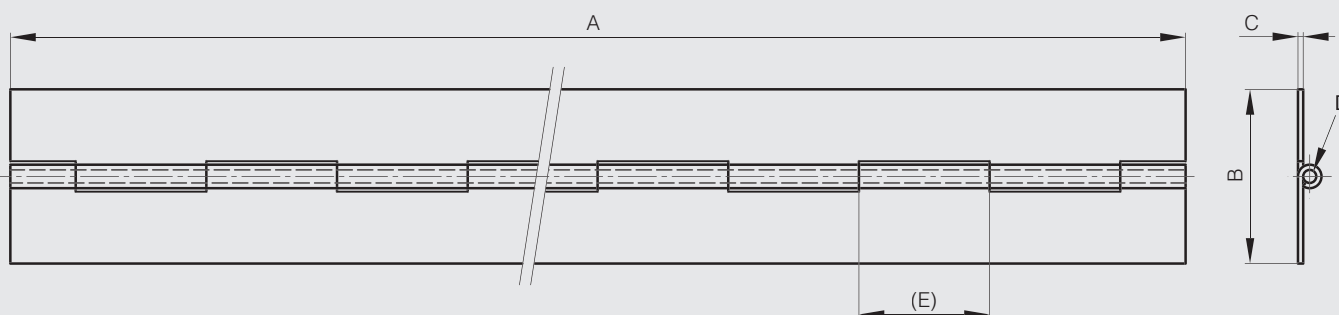



Rolled knuckle continuous hinge - 80 mm width



Opening angle 270°. Other lengths and pin materials are available on request. Specific drilling requirements are also available on request.

Part number	Material	Finish	A	B	C	D	E	F	G	S	Pin material	Note	Weight (g)
42-1-4463	304 stainless steel	raw	1950	80	1.5	3	12.5				stainless steel	undrilled	2170
42-1-3304	304 stainless steel	raw	1000	80	3	6	40				stainless steel	undrilled	2530
42-1-3569	304 stainless steel	raw	2000	80	3	6	40				stainless steel	undrilled	5060
NEW 42-1-4547	304 stainless steel	raw	2000	80	3	6	40	35	60	5.2	stainless steel	drilled	5000
NEW 42-1-4548	316L stainless steel	raw	1980	80	2	6	30				stainless steel	undrilled	3470



Rolled knuckle continuous hinge - 100 mm width



Opening angle 270°. Other lengths and pin materials are available on request. Specific drilling requirements are also available on request.

Part number	Material	Finish	A	B	C	D	E	Pin material	Note	Weight (g)
42-1-4459	304 stainless steel	raw	2000	100	3	6	40	stainless steel	undrilled	5930
42-1-4458	304 stainless steel	raw	1995	100	3	10	40	stainless steel	undrilled	7110



Rolled knuckle continuous hinge - 120 mm width



Opening angle 270°. Other lengths and pin materials are available on request. Specific drilling requirements are also available on request.

Part number	Material	Finish	A	B	C	D	E	Pin material	Note	Weight (g)
42-1-4095	304 stainless steel	raw	2100	120	2	6	30	stainless steel	undrilled	5000

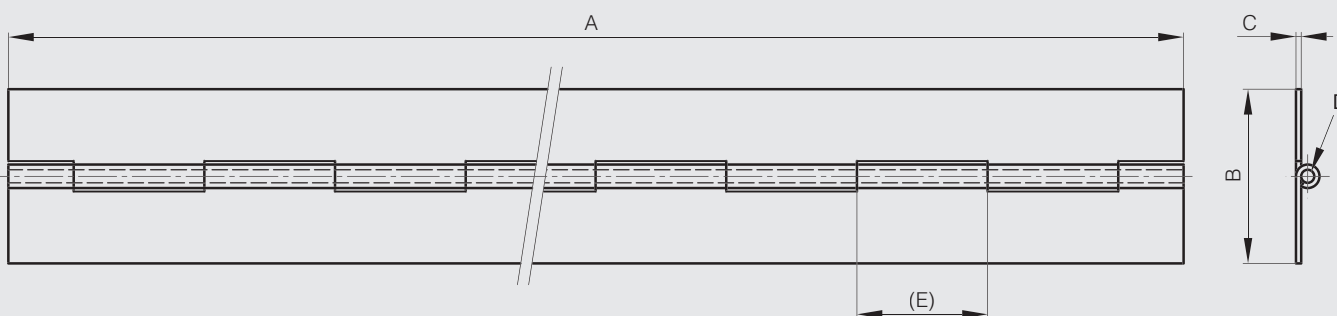



Drilled continuous hinge with one cranked leaf

Opening angle 270°. Other lengths and pin materials are available on request.
Specific drilling requirements are also available on request.



Part number	Material	Finish	A	B	C	D	E	F	G	H	S	Pin material	Note	Weight (g)
39-1-3630	304 stainless steel	raw	1995	31.5	1	2	30	7.5	60	20	3.5	304 stainless steel	drilled	860

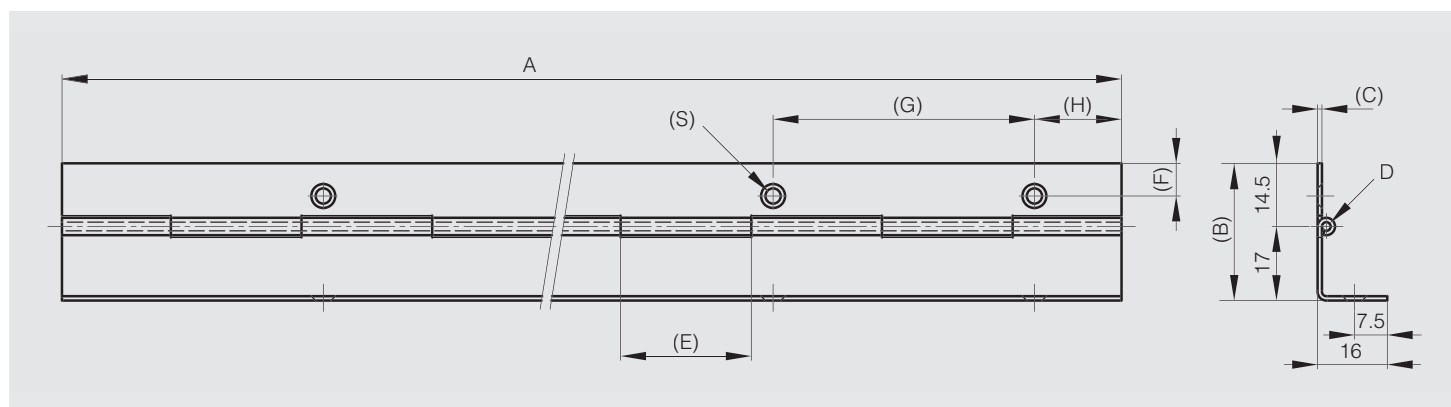

Undrilled continuous hinge with one cranked leaf

Opening angle 270°. Other lengths and pin materials are available on request.
Specific drilling requirements are also available on request.



Part number	Material	Finish	A	B	C	D	E	Pin material	Note	Weight (g)
39-1-3633	304 stainless steel	raw	1995	44	1.5	3	25	304 stainless steel	undrilled	1787
39-1-3300	430 stainless steel	raw	1600	44	1.5	3	25	304 stainless steel	undrilled	1430

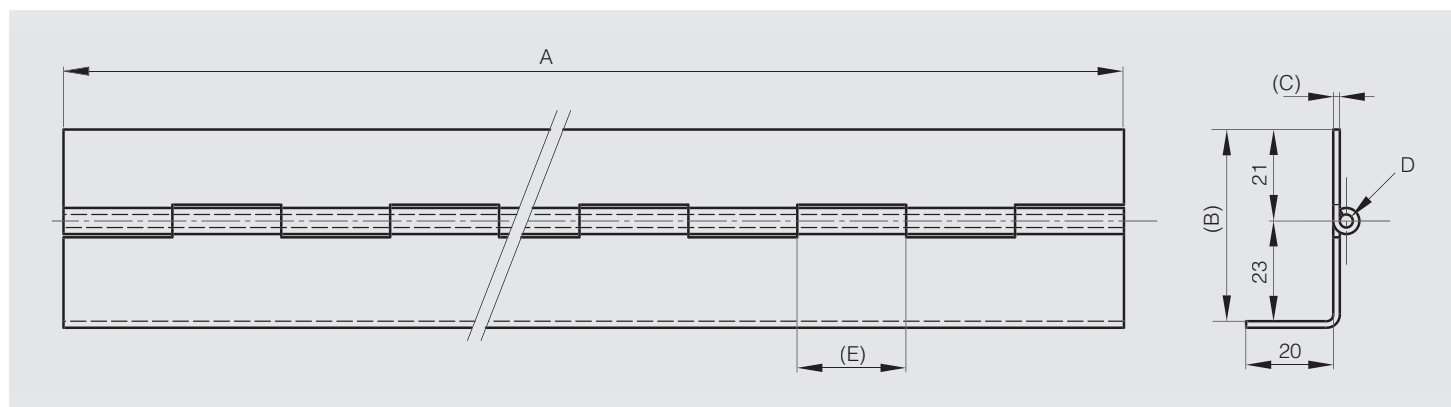



Continuous hinges

Continuous hinge with two cranked leaves

Opening angle 270°. Other lengths and pin materials are available on request.
Specific drilling requirements are also available on request.



Part number	Material	Finish	A	B	C	D	E	Pin material	Note	Weight (g)
39-1-3635	304 stainless steel	raw	2000	46	1.5	3	25	304 stainless steel	undrilled	1944

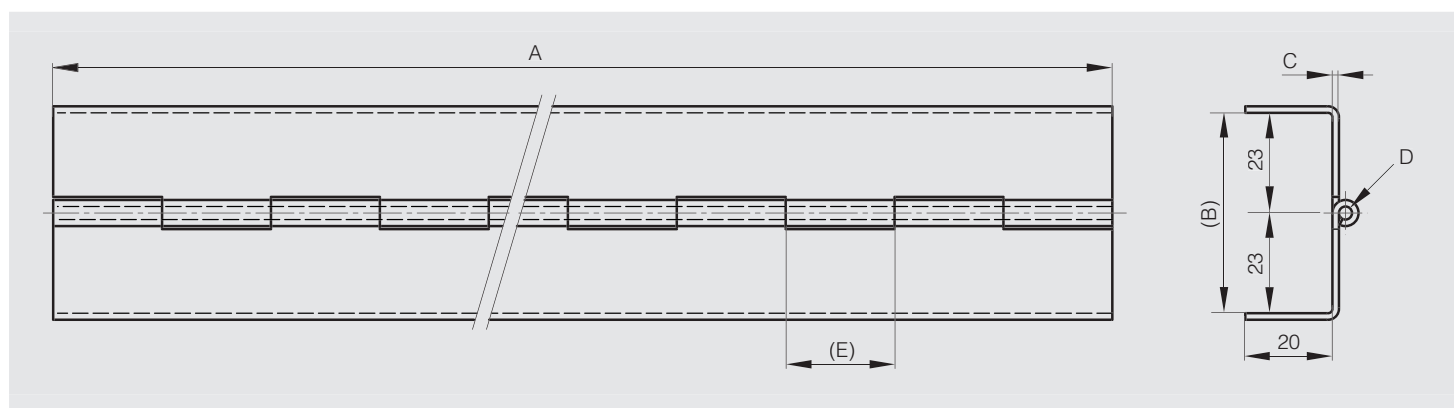

Rolled knuckle continuous hinge "Imperial" dimension



Part number	Material	Finish	A	B	C	D	E	Pin material	Note	Weight (g)
42-1-4096	304 stainless steel	raw	6'	1"	0.04"	0.08"	5/8"	stainless steel	undrilled	500
42-1-4089	304 stainless steel	raw	6'	1" 1/4	0.04"	0.08"	5/8"	stainless steel	undrilled	500
42-1-4346	304 stainless steel	raw	6'	1" 1/4	3/64"	1/8"	3/4"	stainless steel	undrilled	790
42-1-4347	304 stainless steel	raw	6'	1" 1/2	3/64"	1/8"	3/4"	stainless steel	undrilled	940
42-1-4348	304 stainless steel	raw	6'	2"	3/64"	1/8"	3/4"	stainless steel	undrilled	1100
42-1-4219	304 stainless steel	raw	6'	2"	1/16"	5/32"	5/8"	stainless steel	undrilled	1500
42-1-4220	304 stainless steel	raw	7'	2" 1/4	1/16"	5/32"	5/8"	stainless steel	undrilled	2000
42-1-4221	304 stainless steel	raw	6'	2" 1/2	1/16"	5/32"	5/8"	stainless steel	undrilled	1800
42-1-4097	304 stainless steel	raw	6'	2" 3/4	1/16"	5/32"	5/8"	stainless steel	undrilled	1900
42-1-4094	304 stainless steel	raw	7'	3"	1/16"	5/32"	5/8"	stainless steel	undrilled	2400
42-1-4095	304 stainless steel	raw	7'	5"	0.08"	1/4"	1" 1/4	stainless steel	undrilled	5000

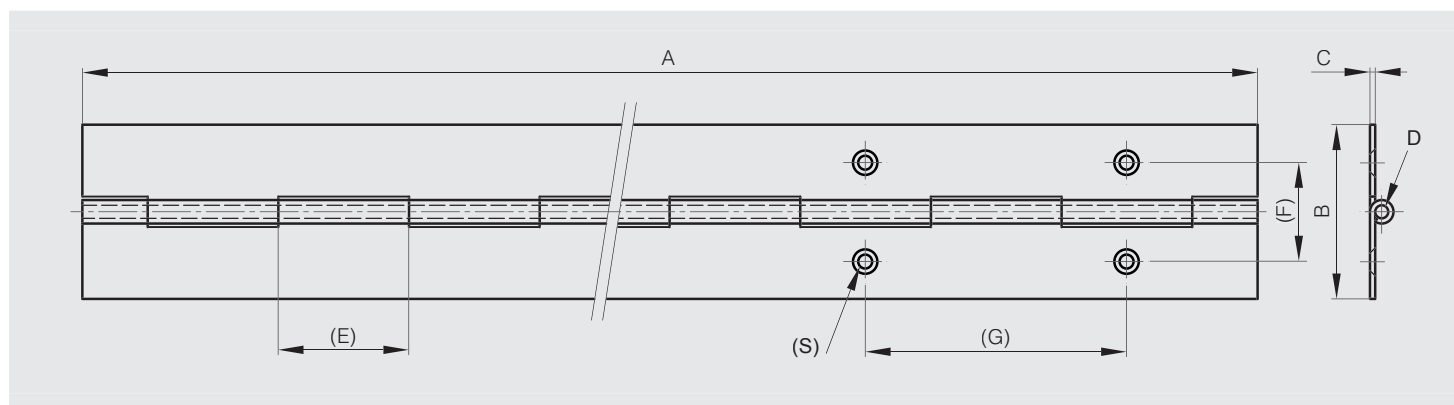



Concealed hinges

Concealed hinges A - 120° opening

Zinc plated steel version: small flat side in raw steel.

Stainless steel version: small flat side in stainless steel.

Natural POM pin diameter 6.

For pin with groove, optimal use of circlips DIN 6799 RS4 or O-ring 99-7-3723 (on request).



Part number	Material	Finish	A	C	D	Pin	Weight (g)
62-1-3570	304 stainless steel	raw	60	2.5	6	304 stainless steel pin	85
62-1-3584	304 stainless steel	raw	60	2.5	6	303 stainless steel grooved pin	85
62-1-3571	304 stainless steel	raw	60	2.5	6	delrin pin	85

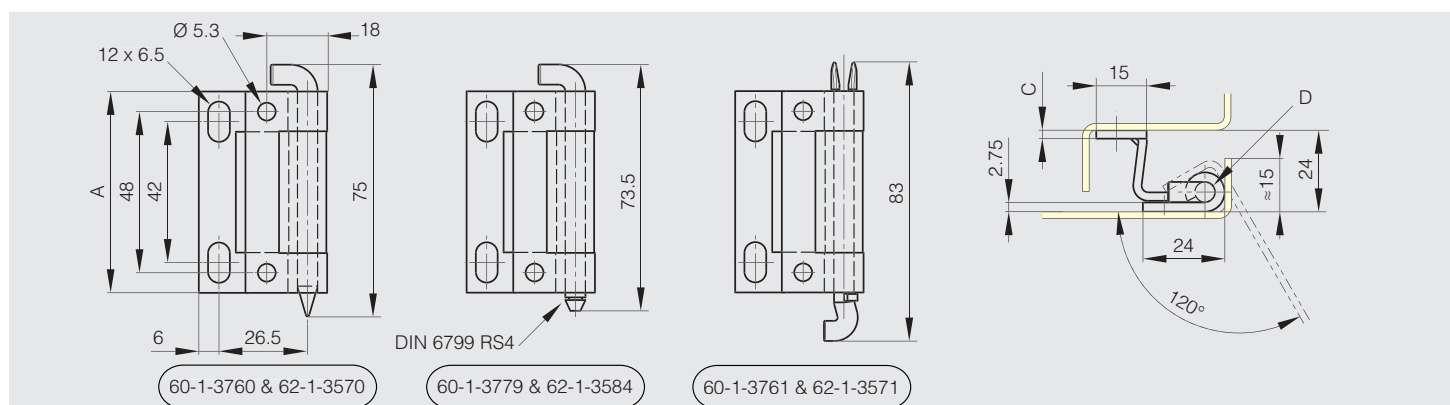

Concealed hinges B - 120° opening

Zinc plated steel version: small flat side in raw steel.

Stainless steel version: small flat side in stainless steel.

Natural POM pin diameter 6.

For pin with groove, optimal use of circlips DIN 6799 RS4 or O-ring 99-7-3723 (on request).



Part number	Material	Finish	A	C	D	Pin	Weight (g)
62-1-3572	304 stainless steel	raw	60	2.5	6	304 stainless steel pin	75
62-1-3585	304 stainless steel	raw	60	2.5	6	303 stainless steel grooved pin	75
62-1-3573	304 stainless steel	raw	60	2.5	6	delrin pin	75

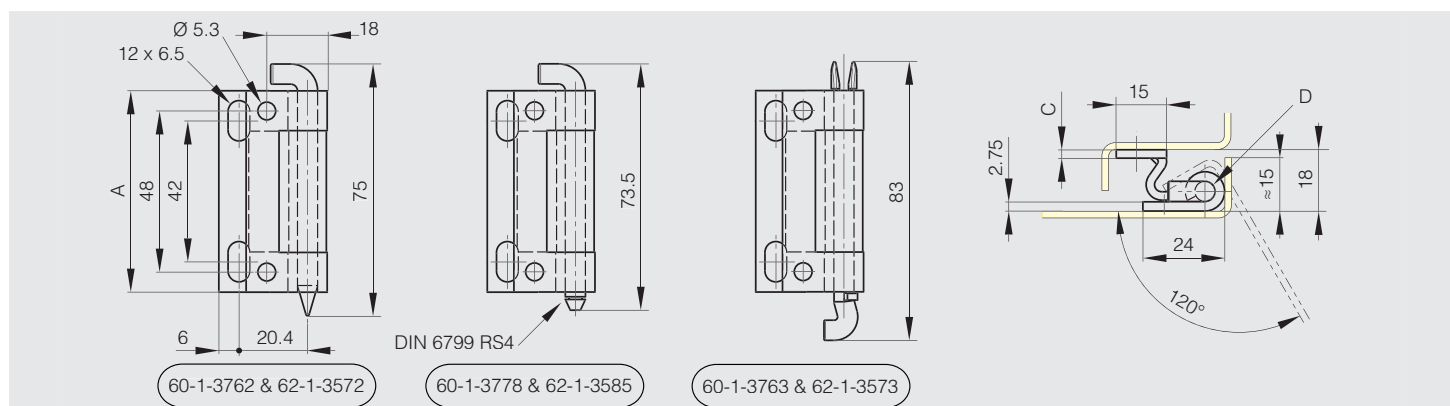



Concealed hinges

Concealed hinges with retractable pin

Quick-release concealed hinge for tool-free door removal with fixed retractable pin.



Part number	Material	Finish	A	B	E	W	Weight (g)
62-1-9000	stainless steel	raw	126	17.5	3	122°	73
62-1-9001	stainless steel	raw	126	20.5	4	117°	84
62-1-9002	stainless steel	raw	126	23.9	4.5	112°	100

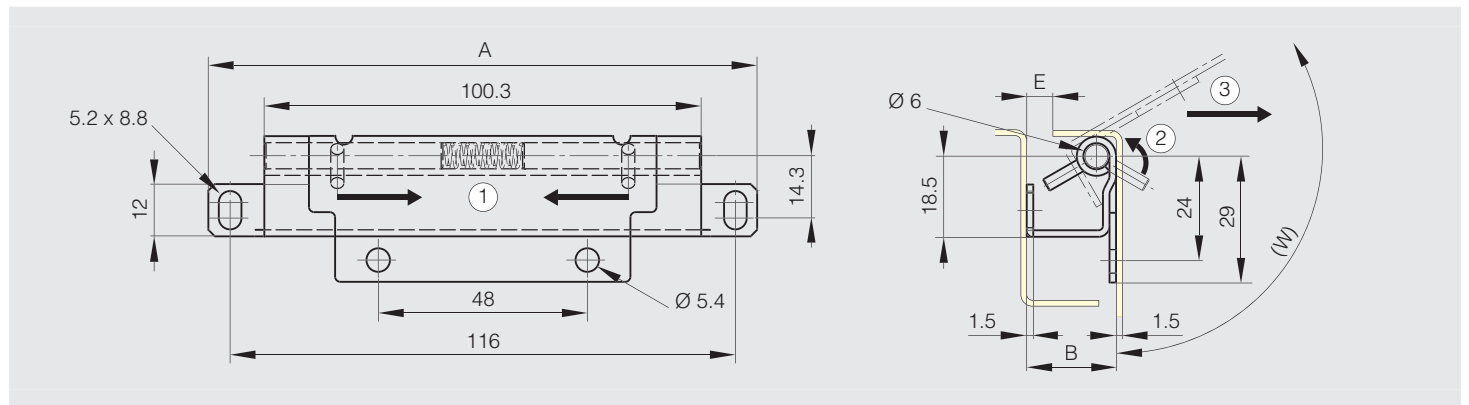

Concealed pin hinges - 100° opening

Non handed fitting.

Removable pin in 304 stainless steel.



Part number	Material	Finish	A	C	D	E	Weight (g)
12-1-3538	304 stainless steel	raw	80	2	4	40	45

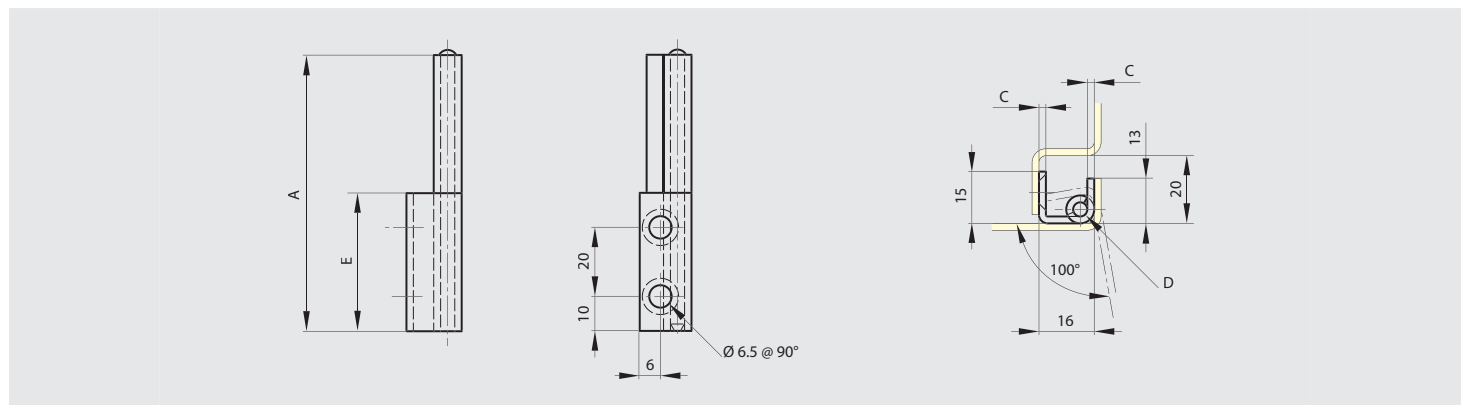



Concealed pin hinges - 120° opening

Non handed fitting.

Removable pin in 304 stainless steel.



Part number	Material	Finish	A	C	D	E	Weight (g)
12-1-3528	304 stainless steel	raw	80	3	6	40	107

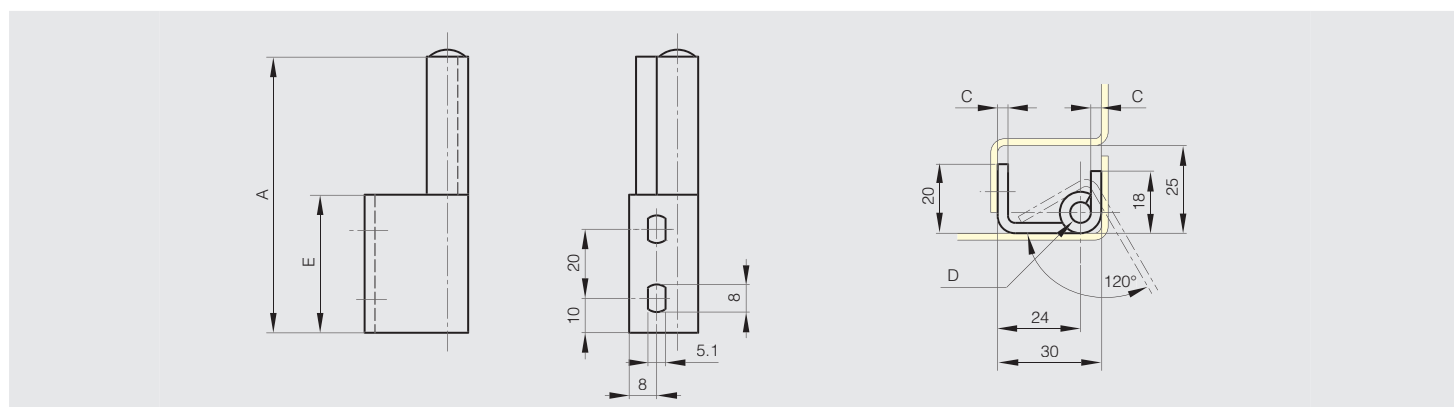

Concealed hinge with friction - 90° opening

Initial torque (0.7 N.m) may vary from -20% to +40%.

For indoor use only.

Can be used both for horizontal and vertical applications.



Part number	Material	Finish	A	B	C	Torque	Weight (g)
70-7-3623	304 stainless steel	polished	40	67	29.5	0.7 N.m	50

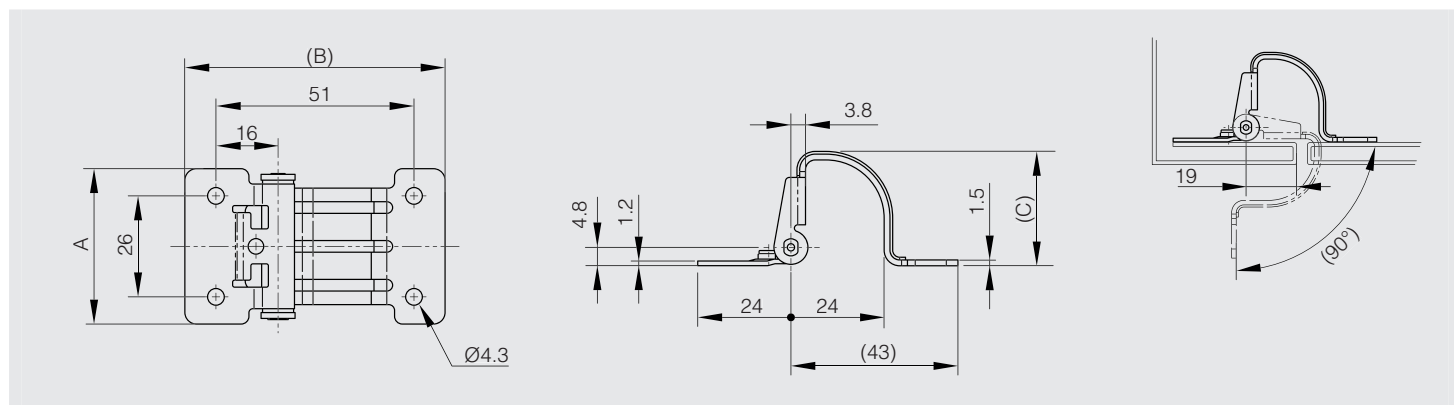



Concealed hinges

Concealed hinges with spring - 95° opening



Concealed hinges with 2 positions:

- Closing position: door remains open with an angle of 10°.
- Opening position: door opens up to 95°.

Closing of door due to spring action and door remains slightly opened.

Applications for parcel box:

- Door automatically opens after code entry.
- Door doesn't remain in opening position.



	Part number	Material	Finish	A	B	C	D	Weight (g)
NEW	71-1-3867	304 stainless steel	raw	51	75	3	6	200

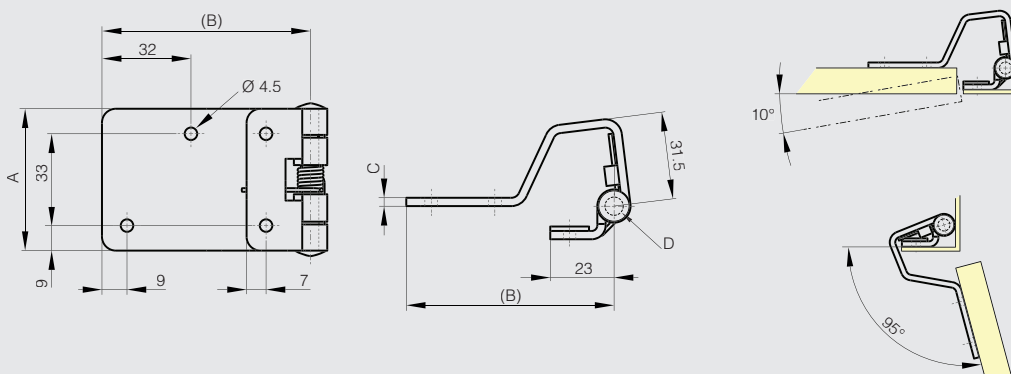

Concealed hinges without spring - 95° opening



	Part number	Material	Finish	A	B	C	D	Weight (g)
NEW	62-1-4008	304 stainless steel	raw	51	75	3	6	210

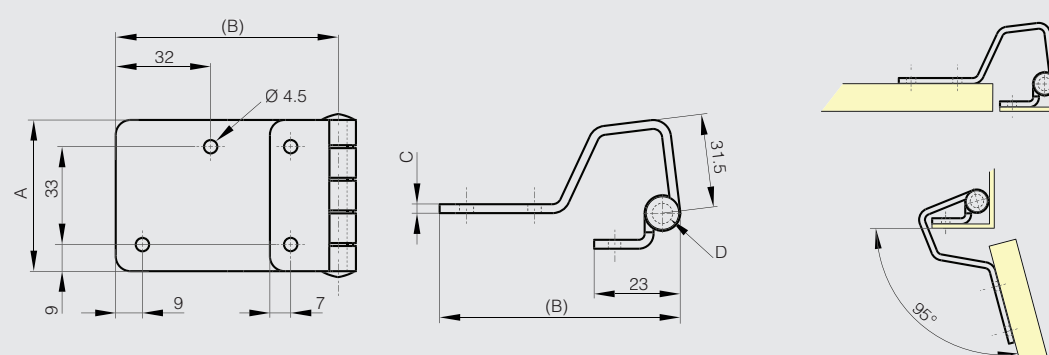



Concealed hinges

Concealed hinge - 180° opening



Part number	Material	Finish	A	B	C	D	E	F	S	Weight (g)
70-7-3544	304 stainless steel	satin	50	19	38	14	18.2	11	2.7	33

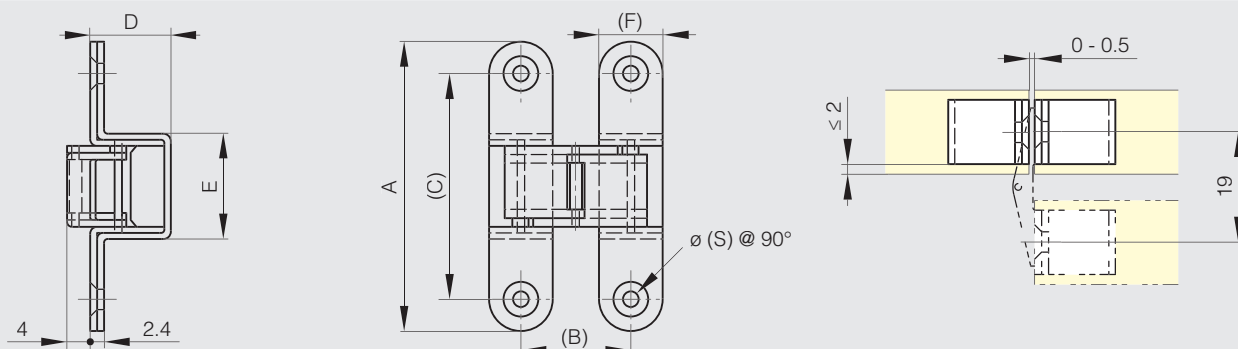

Concealed heavy duty hinge for flush doors - 90° opening

Concealed hinge for LH or RH application. The 2 main hinge parts have a central guide to prevent door from sagging during adjustment.



Part number	Material	Finish	A	B	C	D	Weight (g)
85-7-2331	304 stainless steel	raw	60	48	3	6	189

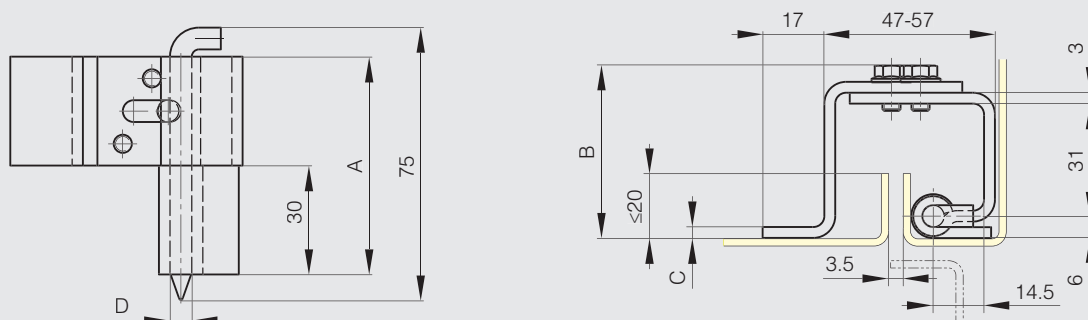



Concealed hinges

Concealed heavy duty hinge for flush doors - 90° opening

Concealed hinge for LH or RH application. The 2 main hinge parts have a central guide to prevent door from sagging during adjustment.



Part number	Material	Finish	A	B	C	D	Weight (g)
85-7-2334	304 stainless steel	raw	80	62	4	8	420

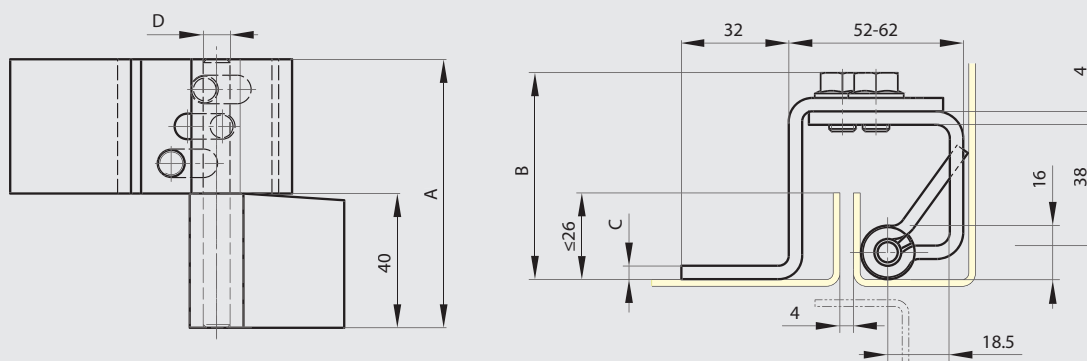

Concealed heavy duty hinge for flush doors - 90° opening

Concealed hinge for LH or RH application. The 2 main hinge parts have a central guide to prevent door from sagging during adjustment.



Part number	Material	Finish	A	B	C	D	Weight (g)
85-7-2332	304 stainless steel	raw	80	61	4	8	412

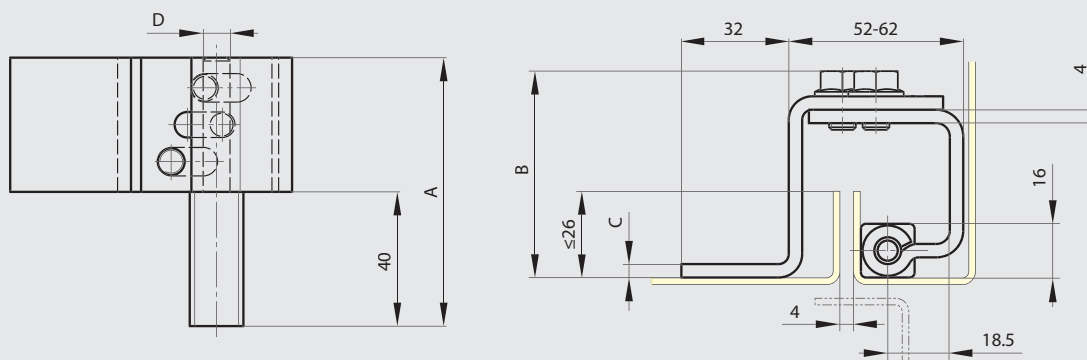



Concealed hinges

Concealed springloaded pin hinges A

Stainless steel spring. Hinges in raw steel and zinc plated steel with a zinc plated pin. Circlip in 1.4122 stainless steel.



Part number	Material	Finish	A	B	C	D	K	Note	Weight (g)
12-1-3858	304 stainless steel	raw	82	18.2	2.8	6	12	type 2	46.4
12-1-3859	304 stainless steel	raw	82	18.2	2.8	6	12	type 1	46.4

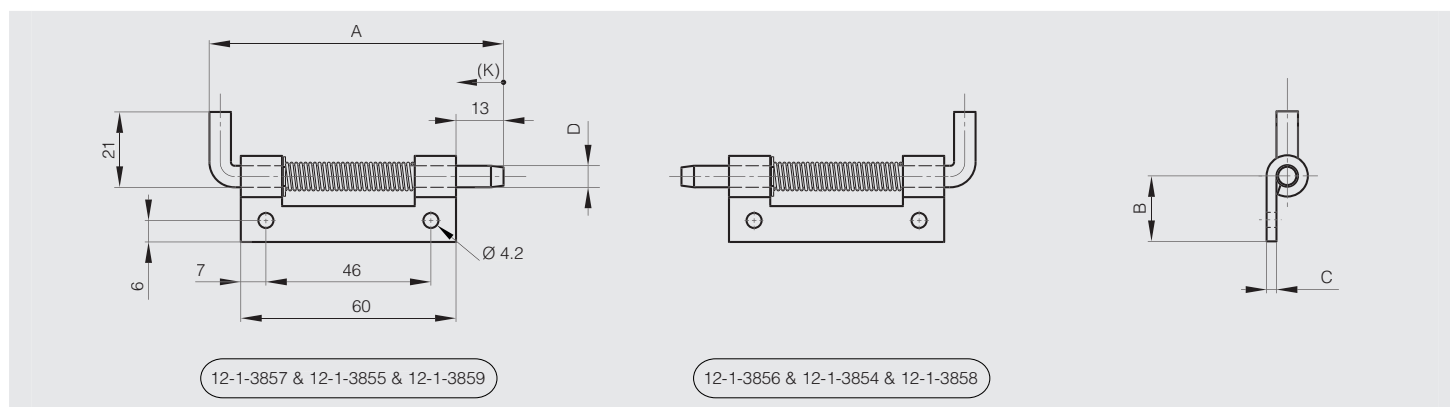

Concealed springloaded pin hinges B

Stainless steel spring. Hinges in raw steel and zinc plated steel with a zinc plated pin. Circlip in 1.4122 stainless steel.



Part number	Material	Finish	A	B	C	D	K	Note	Weight (g)
12-1-3862	304 stainless steel	raw	82	21	14	5	12	type 2	38.5
12-1-3863	304 stainless steel	raw	82	21	14	5	12	type 1	38.5

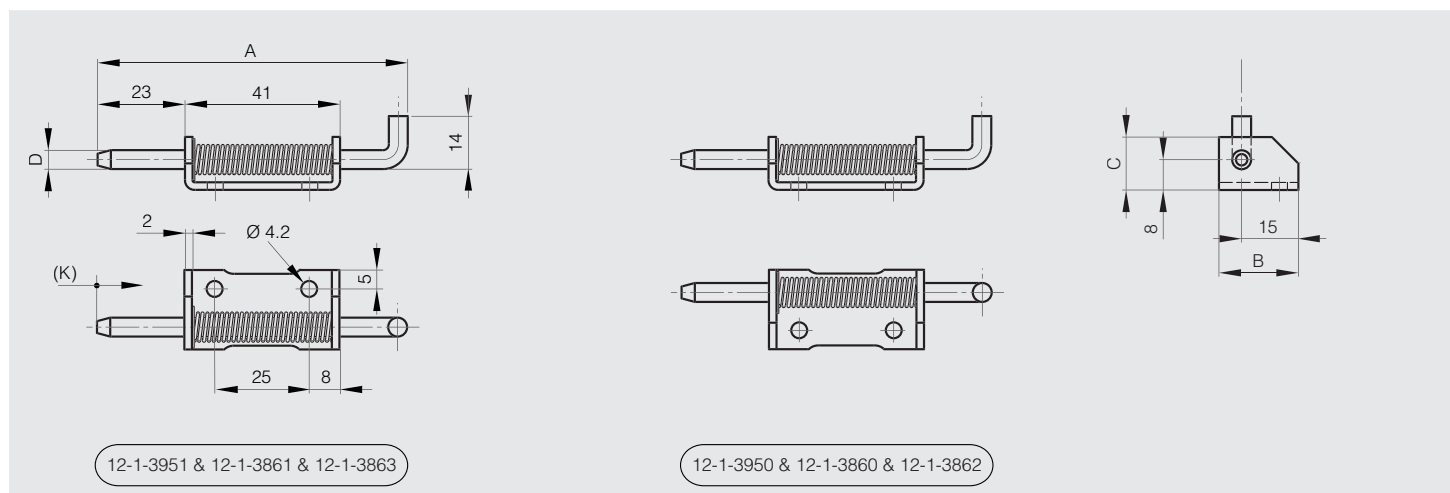



Concealed hinges - 90° opening



Pins and links in 316L stainless steel for 70-1-3625.

Mounting features:

- For nested doors or surface mounted doors.
- LH or RH options.
- For horizontal or vertical applications.

A full product data sheet is available on our website.

Refer to the product data sheet on our website for mounting instructions.



	Part number	Material	Finish	A	B	C	Weight (g)
NEW	70-1-3625	316L stainless steel	raw	44	29	32	64

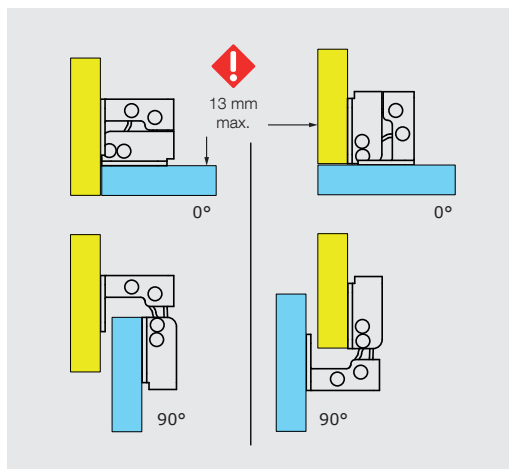
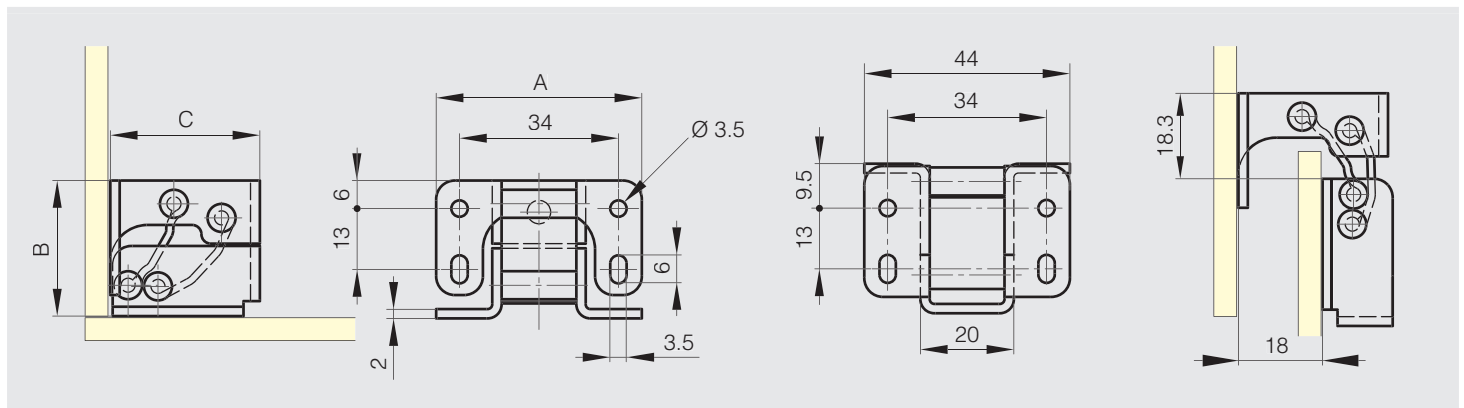

Nested door assembly shown

Surface mounted assembly shown

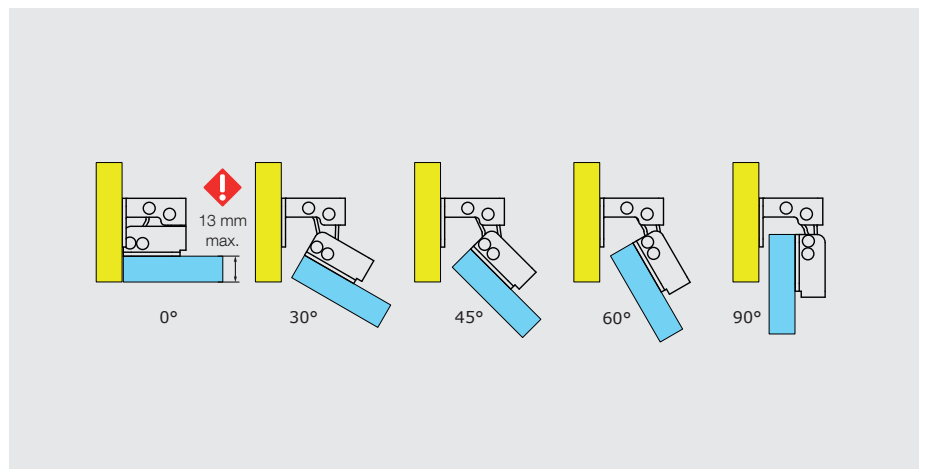

Nested door assembly shown



Concealed hinges - 125° opening



Links in aluminium.

Pins in 304 Cu stainless steel for 70-1-3640.

Mounting features:

- For nested doors or surface mounted doors.
- LH or RH options.
- For horizontal or vertical applications.

Opening angle differs according to door thickness:

- 2 mm thickness: opening angle of 125°.
- 8 mm thickness: opening angle of 110°.
- 13 mm thickness: opening angle of 100°.

Please ask us for bespoke solutions.



	Part number	Material	Finish	A	B	C	Weight (g)
NEW	70-1-3640	316L stainless steel	raw	44	29	32	60

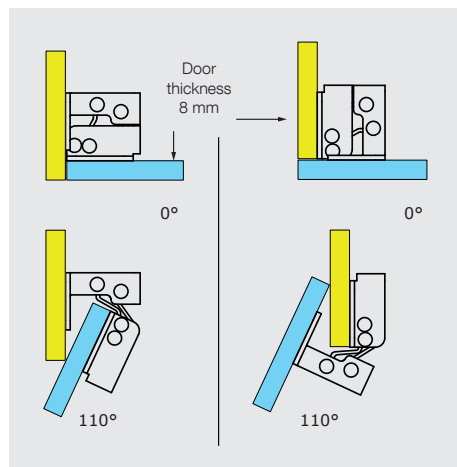
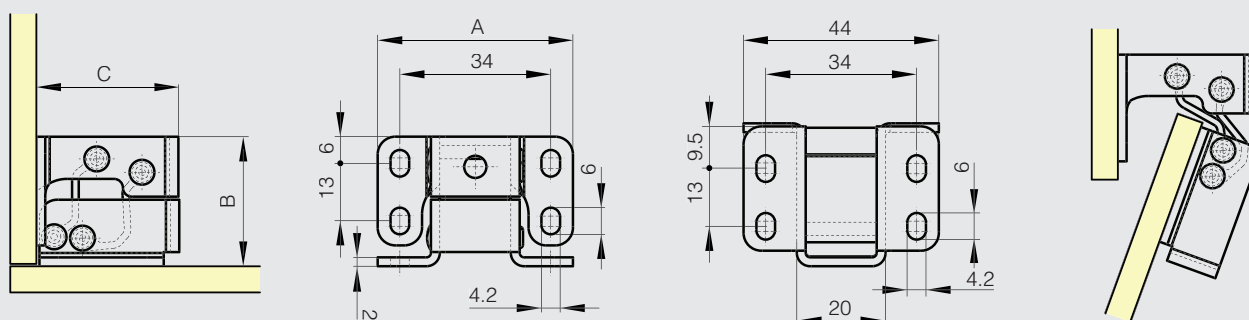

Nested door assembly shown

Surface mounted assembly shown

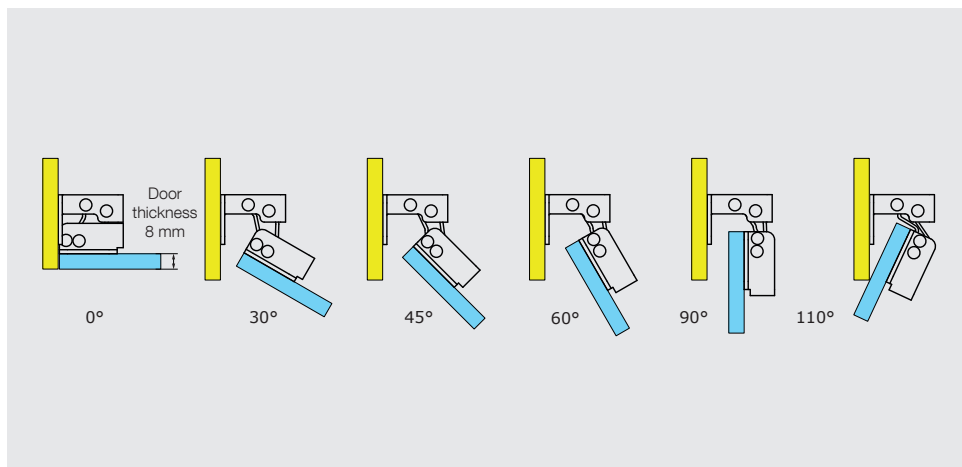

Nested door assembly shown



Concealed hinges

Spring loaded concealed hinges - 90° opening



Part number	Material	Finish	A	B	C	Weight (g)
70-1-9000	316 stainless steel	raw	44	104.5	26	70

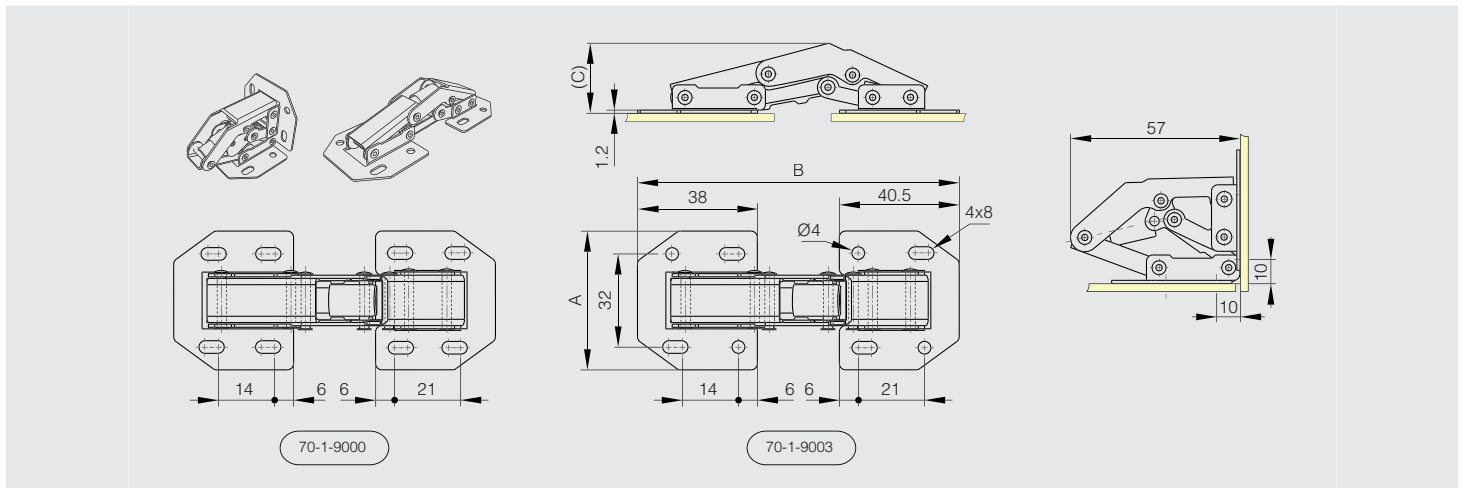

Spring loaded concealed hinges - 150° opening



For door thickness max: 20 mm.

Part number	Material	Finish	A	B	C	Weight (g)
70-1-9002	304 stainless steel	raw	52	121	73.5	140

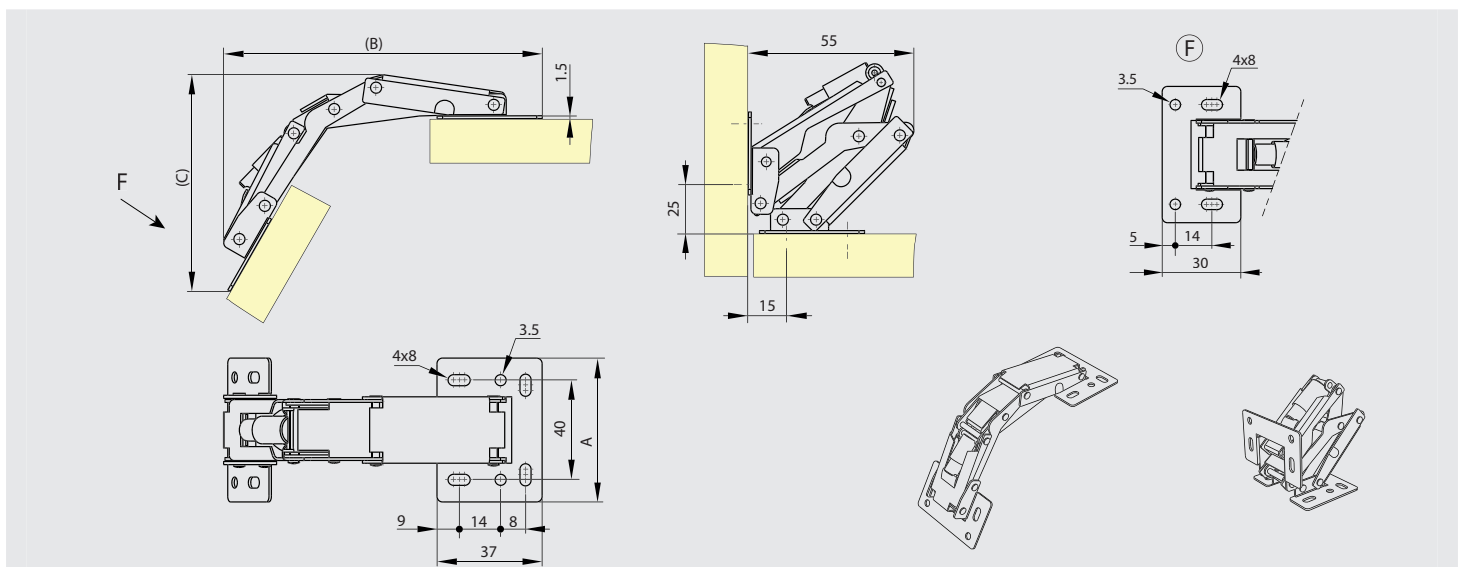



Stainless steel range - Hinges

Concealed hinges

Concealed hinges with two cranked leaves - undrilled - 120° opening - version A

Hinges for side door of baggage compartment (bus and coach, bodywork...)



	Part number	Material	Finish	A	B	C	D	E	Weight (g)
NEW	39-1-3885	304 stainless steel	raw	300	44.1	1.5	3	12.5	440
NEW	39-1-3887	304 stainless steel	raw	600	44.1	1.5	3	12.5	880

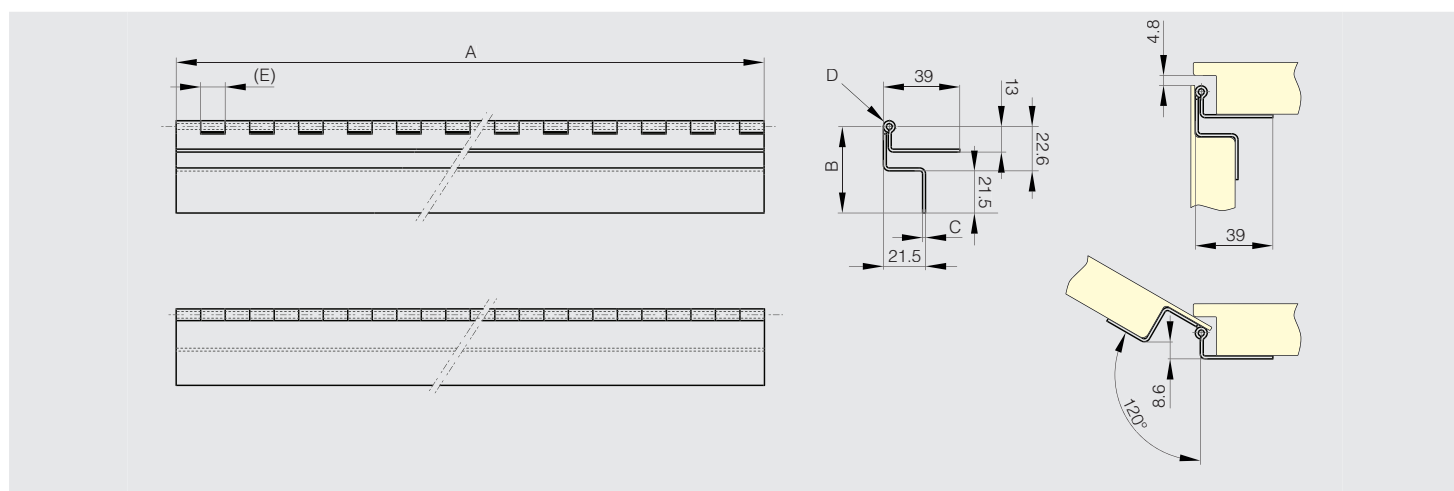

Concealed hinges with two cranked leaves - drilled - 120° opening - version A

Hinges for side door of baggage compartment (bus and coach, bodywork...)

Use rivets for 4.2 diameter holes (door side).

Use self-drilling screws for 12.2 diameter holes (frame side).



	Part number	Material	Finish	A	B	C	D	E	G	H	Weight (g)
NEW	39-1-3886	304 stainless steel	raw	300	44.1	1.5	3	12.5	160	70	430
NEW	39-1-3888	304 stainless steel	raw	600	44.1	1.5	3	12.5	160	60	870

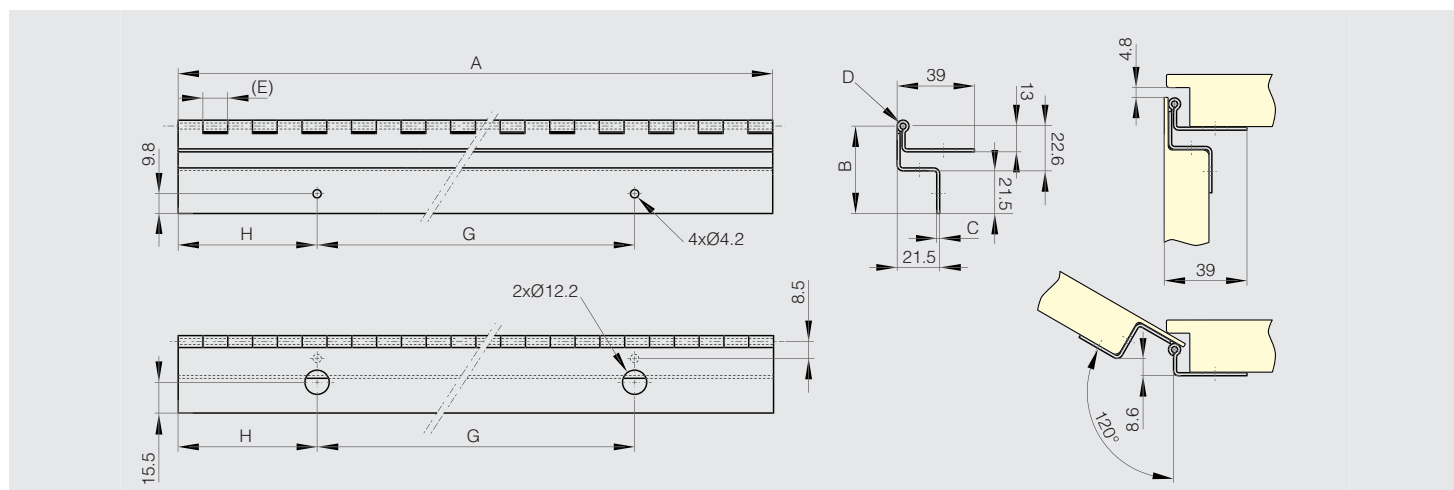



Stainless steel range - Hinges

Concealed hinges

Concealed hinges with two cranked leaves - undrilled - 120° opening - version B

Hinges for side door of baggage compartment (bus and coach, bodywork...)



	Part number	Material	Finish	A	B	C	D	E	Weight (g)
NEW	39-1-3889	304 stainless steel	raw	300	54.1	1.5	3	12.5	410
NEW	39-1-3891	304 stainless steel	raw	600	54.1	1.5	3	12.5	870

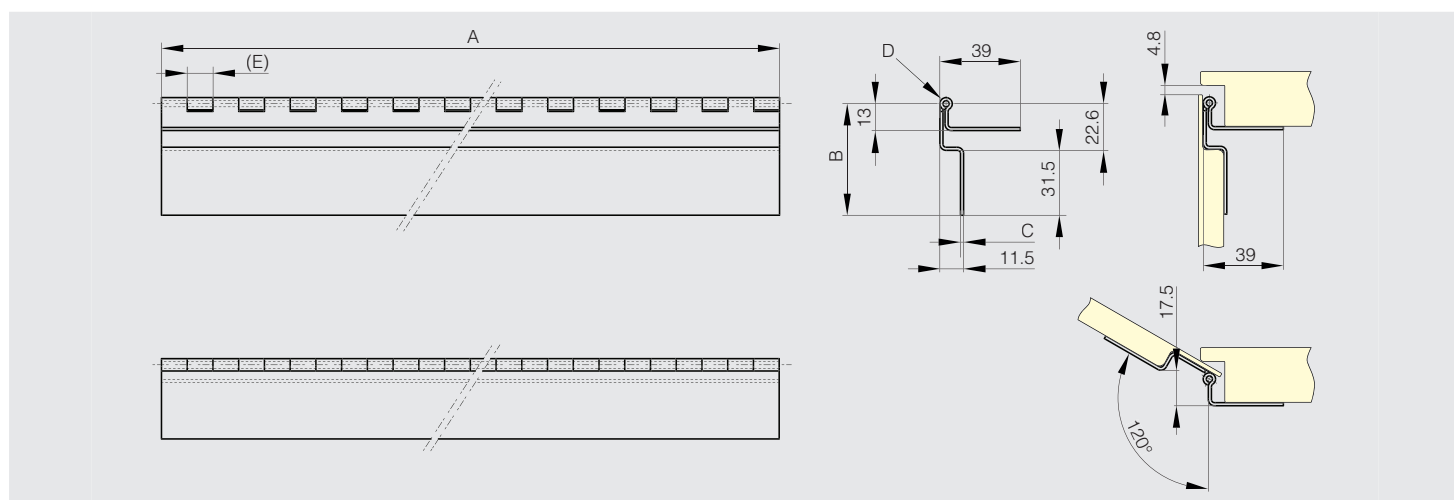

Concealed hinges with two cranked leaves - drilled - 120° opening - version B

Hinges for side door of baggage compartment (bus and coach, bodywork...)

Use rivets for 4.2 diameter holes (door side).

Use self-drilling screws for 12.2 diameter holes (frame side).



	Part number	Material	Finish	A	B	C	D	E	G	H	J	K	L	Weight (g)
NEW	39-1-3890	304 stainless steel	raw	300	54.1	1.5	3	12.5	160	30	80	70	160	430
NEW	39-1-3892	304 stainless steel	raw	600	54.1	1.5	3	12.5	260	40	130	60	160	870

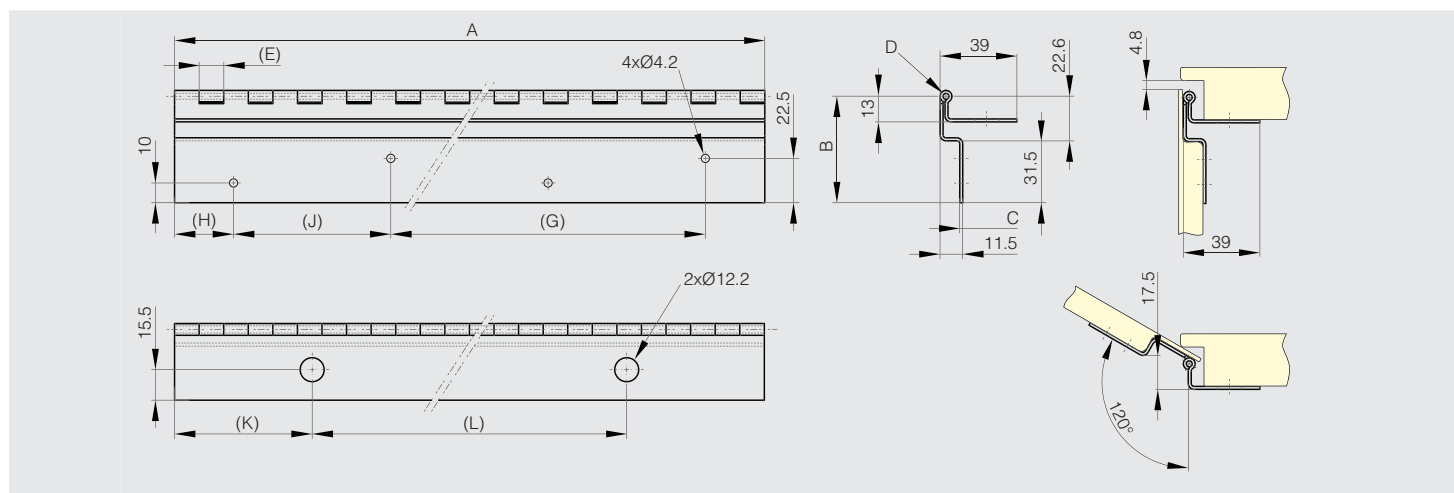



Stainless steel range - Hinges

Hinges with dual function

Opening spring hinges 120 mm long

Opening spring force:

$M(0^\circ)$: 0.85 N.m / $M(90^\circ)$: 0.56 N.m / $M(180^\circ)$: 0.28 N.m

Stainless steel spring.



Part number	Material	Finish	A	B	C	D	F	G	S	Note	Weight (g)
71-1-3787	304 stainless steel	raw	120	40	1.5	4				undrilled	82
71-1-3793	304 stainless steel	raw	120	40	1.5	4	22.7	60	4	drilled	82

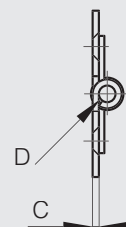
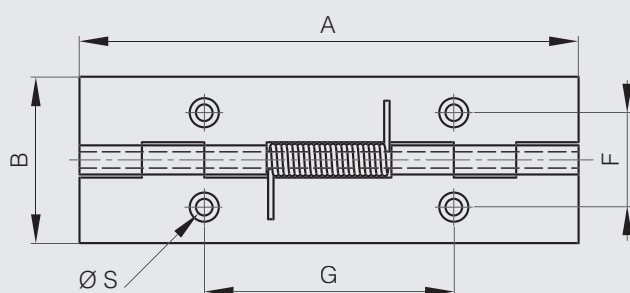

Closing spring hinges 120 mm long

Closing spring force:

$M(0^\circ)$: 0.28 N.m / $M(90^\circ)$: 0.56 N.m / $M(180^\circ)$: 0.85 N.m

Stainless steel spring.



Part number	Material	Finish	A	B	C	D	F	G	S	Note	Weight (g)
71-1-3790	304 stainless steel	raw	120	40	1.5	4				undrilled	82
71-1-3796	304 stainless steel	raw	120	40	1.5	4	22.7	60	4	drilled	82

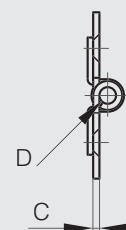
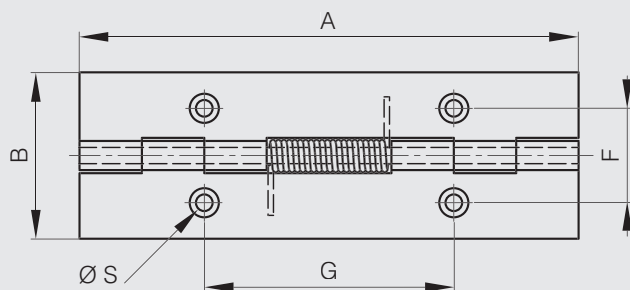



Opening spring hinges 180 mm long

Opening spring force:

$M(0^\circ)$: 1.7 N.m / $M(90^\circ)$: 1.1 N.m / $M(180^\circ)$: 0.56 N.m

Stainless steel spring.



Part number	Material	Finish	A	B	C	D	F	G	S	Note	Weight (g)
71-1-3788	304 stainless steel	raw	180	40	1.5	4				undrilled	124
71-1-3794	304 stainless steel	raw	180	40	1.5	4	22.7	60	4	drilled	124

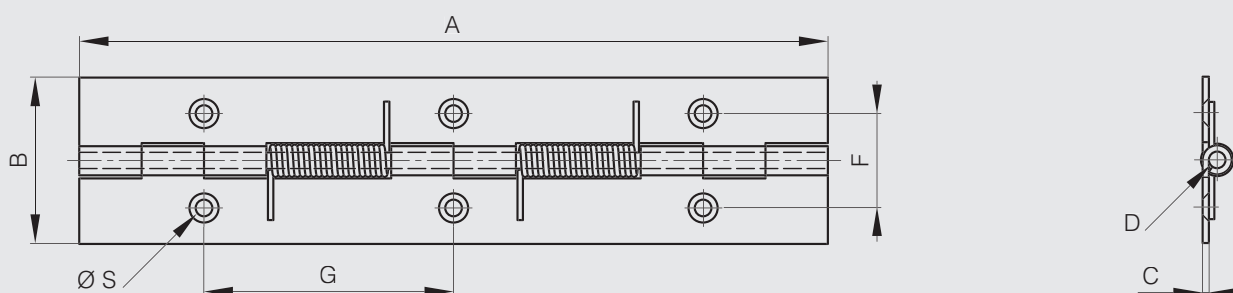

Closing spring hinges 180 mm long

Closing spring force:

$M(0^\circ)$: 0.56 N.m / $M(90^\circ)$: 1.1 N.m / $M(180^\circ)$: 1.7 N.m

Stainless steel spring.



Part number	Material	Finish	A	B	C	D	F	G	S	Note	Weight (g)
71-1-3791	304 stainless steel	raw	180	40	1.5	4				undrilled	124
71-1-3797	304 stainless steel	raw	180	40	1.5	4	22.7	60	4	drilled	124

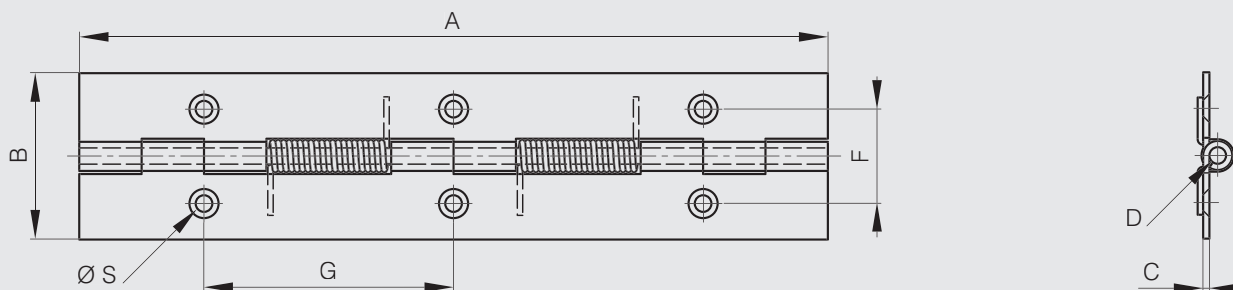



Opening spring hinges 240 mm long

Opening spring force:

M(0°): 2.55 N.m / M(90°): 1.68 N.m / M(180°): 0.84 N.m

Stainless steel spring.



Part number	Material	Finish	A	B	C	D	F	G	S	Note	Weight (g)
71-1-3789	304 stainless steel	raw	240	40	1.5	4				undrilled	164
71-1-3795	304 stainless steel	raw	240	40	1.5	4	22.7	60	4	drilled	164

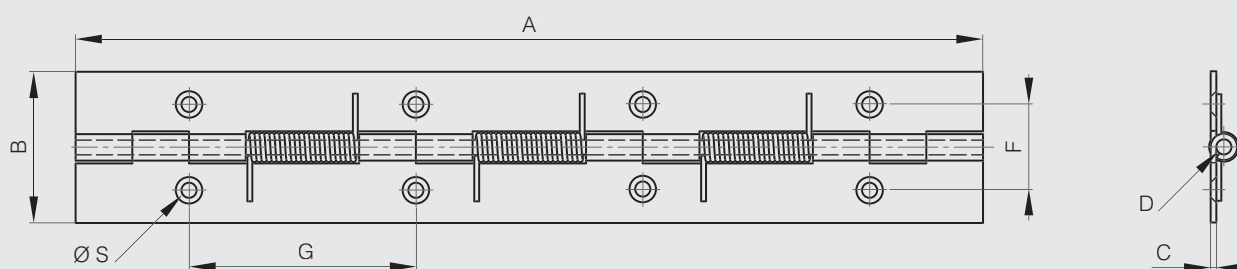

Closing spring hinges 240 mm long

Closing spring force:

M(0°): 0.84 N.m / M(90°): 1.68 N.m / M(180°): 2.55 N.m

Stainless steel spring.



Part number	Material	Finish	A	B	C	D	F	G	S	Note	Weight (g)
71-1-3792	304 stainless steel	raw	240	40	1.5	4				undrilled	164
71-1-3798	304 stainless steel	raw	240	40	1.5	4	22.7	60	4	drilled	164

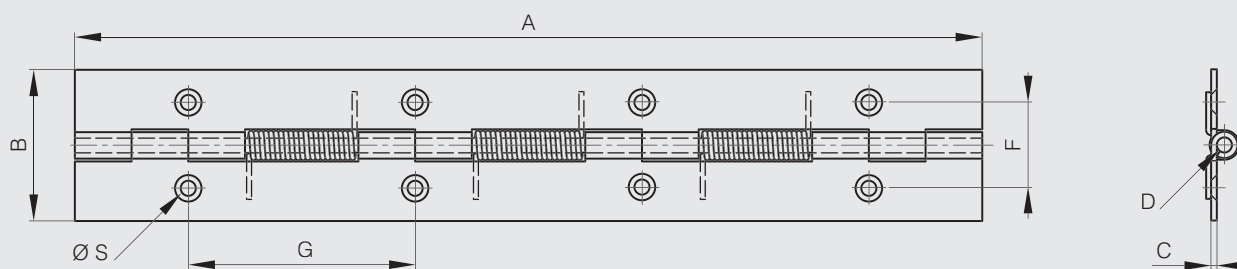



Stainless steel range - Hinges

Hinges with dual function

Spring hinges 50 mm long

Opening spring force:

M(0°): 1.5 N.m / M(90°): 1.1 N.m / M(180°): 0.65 N.m

Closing spring force :

M(0°): 0.25 N.m / M(90°): 0.65 N.m / M(180°): 1.1 N.m



Part number	Material	Finish	A	B	C	D	F	G	S	Note	Weight (g)
71-1-3553	304 stainless steel	raw	50	50	2	4	10	30	5	stainless steel opening spring	50
71-1-3586	304 stainless steel	raw	50	50	2	4	10	30	5	stainless steel closing spring	50

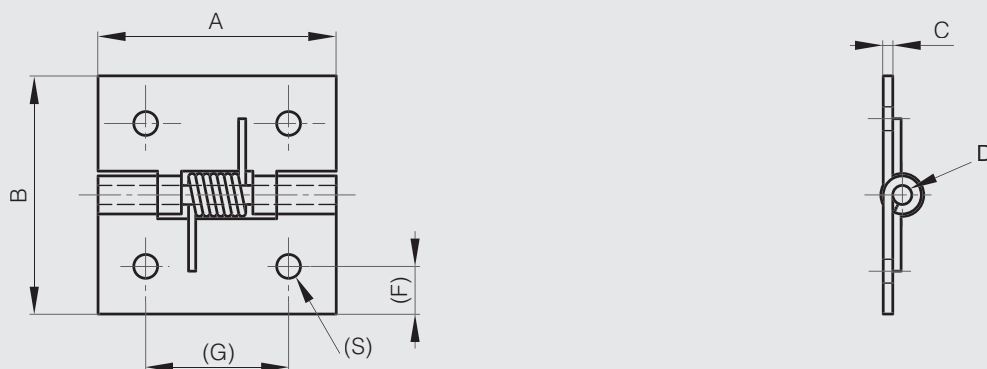

Spring hinge 60 mm long - with 4 holes

Opening spring force:

M(0°): 0.11 N.m / M(90°): 0.09 N.m / M(180°): 0.07 N.m



Part number	Material	Finish	A	B	C	D	F	G	S1	S2	Note	Weight (g)
71-1-3560	430 stainless steel	raw	60	35	1	3	7.5	35	3.1	5	stainless steel opening spring	22

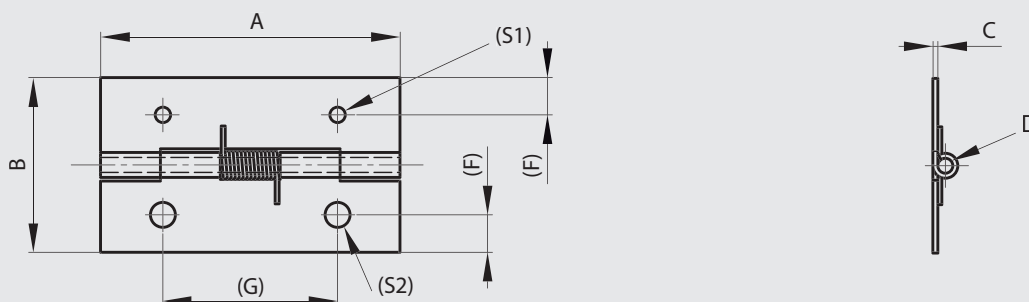



Spring hinges 75 mm long - drilled

Opening spring force:

M(0°): 0.12 N.m / M(90°): 0.09 N.m / M(180°): 0.06 N.m



Part number	Material	Finish	A	B	C	D	F	G	S	Note	Weight (g)
71-1-3582	304 stainless steel	raw	75	20	0.8	2	11.2	60	2.8	stainless steel opening spring	11.5

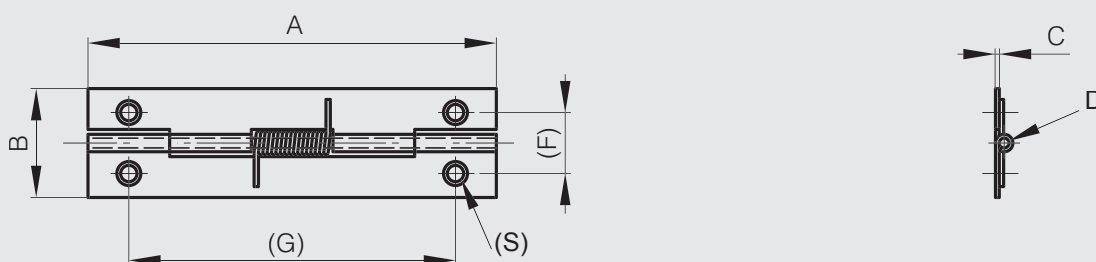

Spring hinges 75 mm long - undrilled

Spring force:

M(0°): 0.12 N.m / M(90°): 0.095 N.m / M(180°): 0.07 N.m



Part number	Material	Finish	A	B	C	D	Note	Weight (g)
71-1-3583	304 stainless steel	raw	75	30	0.8	2	stainless steel opening spring	17

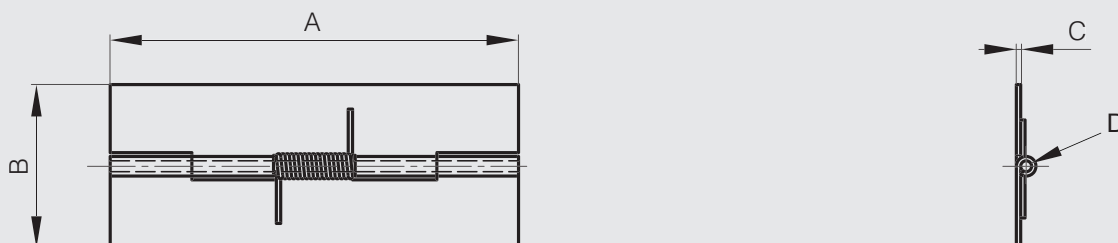



Spring hinges 80 mm long

Opening spring force:

M(0°): 0.17 N.m / M(90°): 0.12 N.m / M(180°): 0.065 N.m



Part number	Material	Finish	A	B	C	D	F	G	S	Note	Weight (g)
71-1-3578	304 stainless steel	raw	80	23.5	1	3	4.5	60	4	stainless steel opening spring	24.5
71-1-3304	430 stainless steel	raw	80	23.5	1	3	4.5	60	4	stainless steel opening spring	24.5

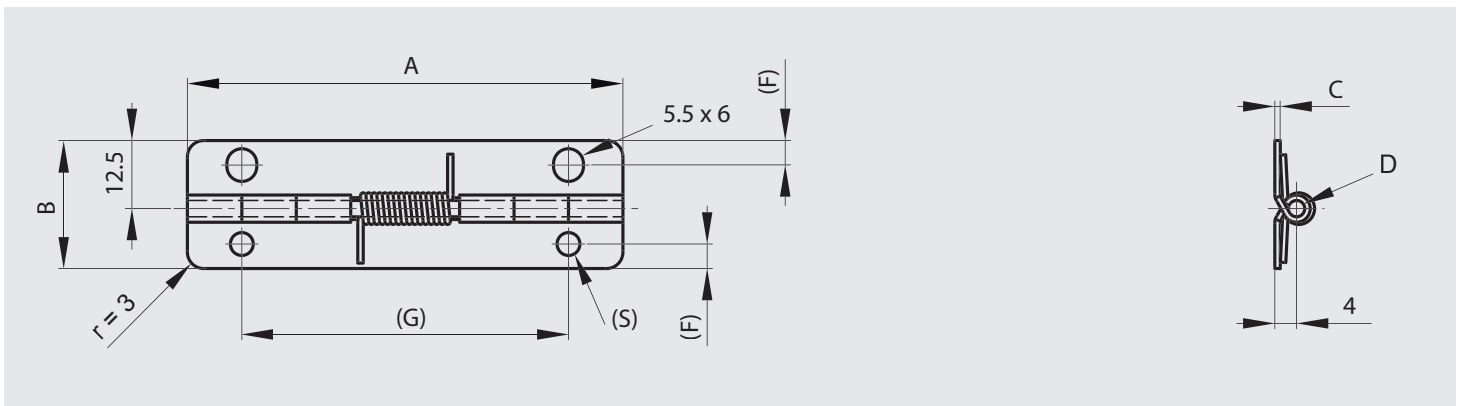

Spring hinges 160 mm long

Spring force for part numbers 71-1-3580 and 71-1-3581:

M(0°): 0.9 N.m / M(90°): 0.86 N.m / M(180°): 0.6 N.m

Spring force for part number 71-1-3618 and 71-1-3835:

M(0°): 0.12 N.m / M(90°): 0.44 N.m / M(180°): 0.55 N.m

Punched pin.



Part number	Material	Finish	A	B	C	D	F	G	S	Note	Weight (g)
71-1-3581	304 stainless steel	raw	160	46	3	6.5	30	70	4.2	stainless steel opening spring	208
71-1-3835	304 stainless steel	raw	160	46	3	6.5	30	70	4.2	stainless steel closing spring	208

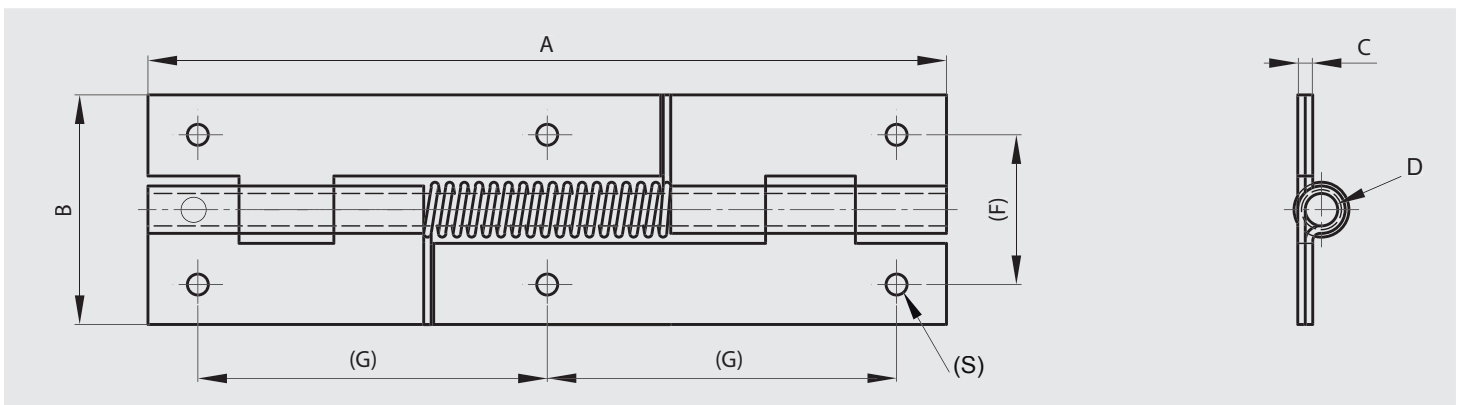



Spring hinges 170 mm long

Spring force:

M(0°): 0.24 N.m / M(90°): 0.19 N.m / M(180°): 0.14 N.m



Part number	Material	Finish	A	B	C	D	Note	Weight (g)
71-1-3522	304 stainless steel	raw	170	30	0.8	2	stainless steel opening spring	41

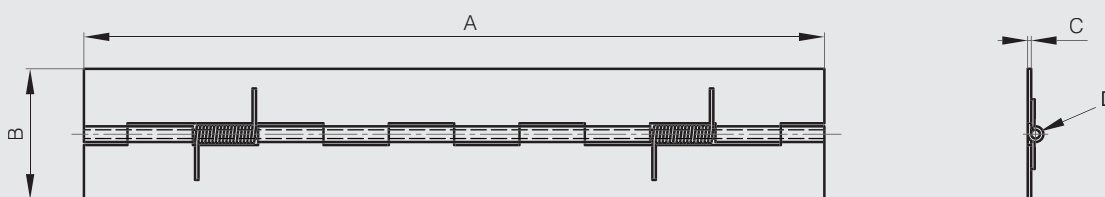

Cranked spring hinge 66 mm long

A full product data sheet is available on our website.



Part number	Material	Finish	A	B	C	D	Note	Weight (g)
71-1-3649	316 stainless steel	brightened	66	22.5	1.5	4	closing spring	38

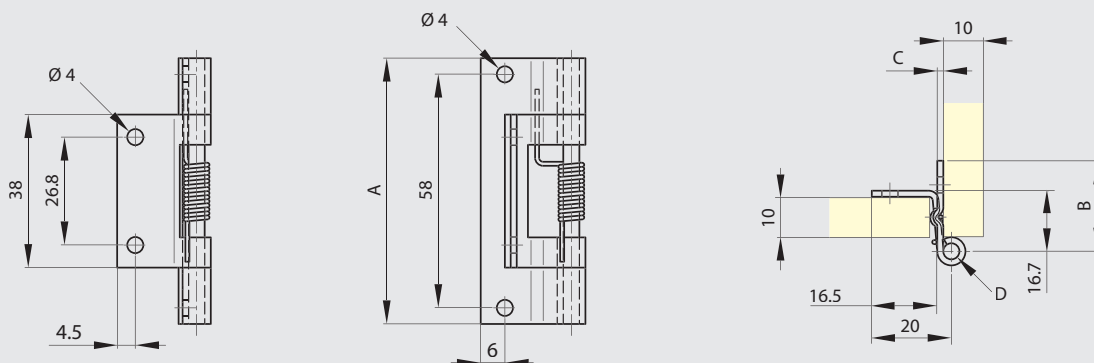



Stainless steel range - Hinges

Hinges with dual function

Cranked spring hinge 60 mm long

A full product data sheet is available on our website.



Part number	Material	Finish	A	B	C	D	Note	Weight (g)
71-1-3622	316 stainless steel	raw	60	30	1.5	3	closing spring	40

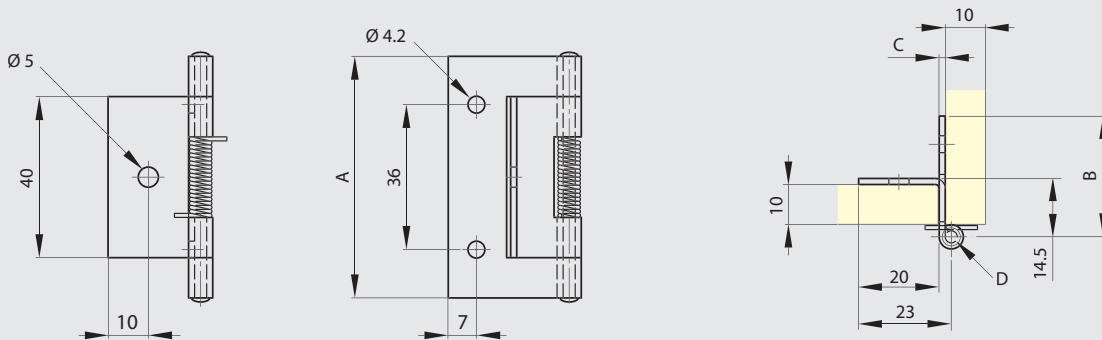

Lift-off rising hinge in stainless steel

Ramp integrated in the pin allows automatic closing by gravity.



Part number	Material	Finish	A	B	C	D	Note	Weight (g)
NEW 14-1-3886	304 stainless steel	brushed	80	80	3	8	type 2	216
NEW 14-1-3892	304 stainless steel	brushed	80	80	3	8	type 1	216

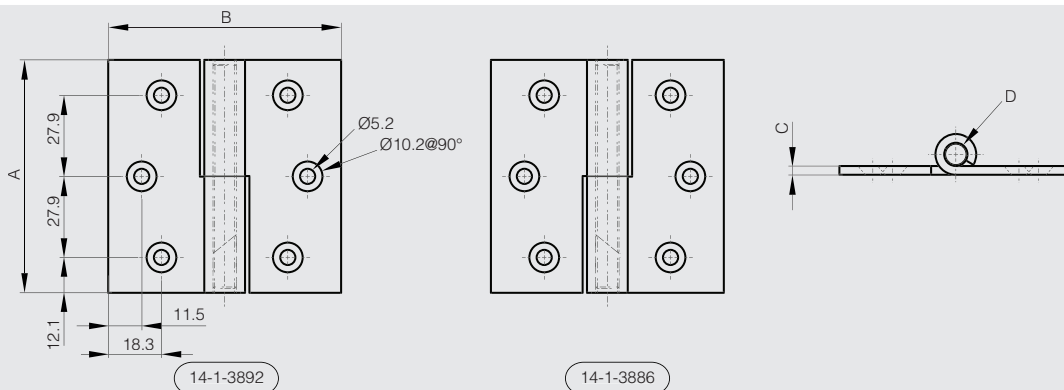



Friction hinge in stainless steel - friction torque 3 N.m



Constant torque. Stable at various temperatures.
Pin in steel.

Part number	Material	Finish	A	B	C	D	Torque	Note	Weight (g)
NEW 62-1-3710	301 stainless steel	raw	85	55	2	8	3 N.m	with friction	120
NEW 62-1-3711	301 stainless steel	raw	85	55	2	8		no torque	120

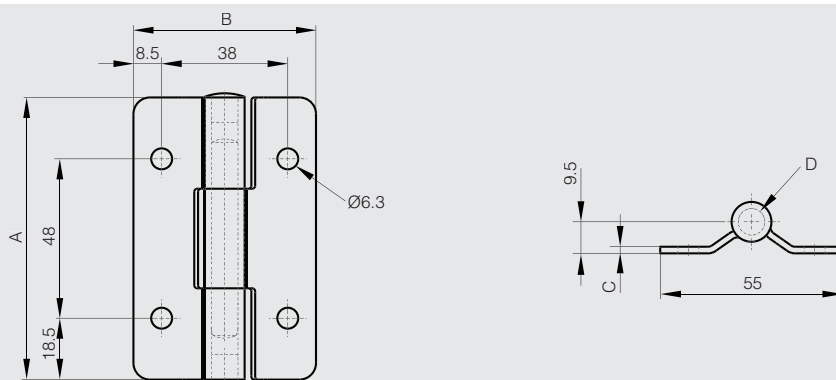

Friction hinge in stainless steel - friction torque 5 N.m



Constant torque. Stable at various temperatures.
Pin in steel.

Part number	Material	Finish	A	B	C	D	Torque	Note	Weight (g)
NEW 62-1-3712	301 stainless steel	raw	85	55	2	12	5 N.m	with torque	155
NEW 62-1-3713	301 stainless steel	raw	85	55	2	12		no torque	155

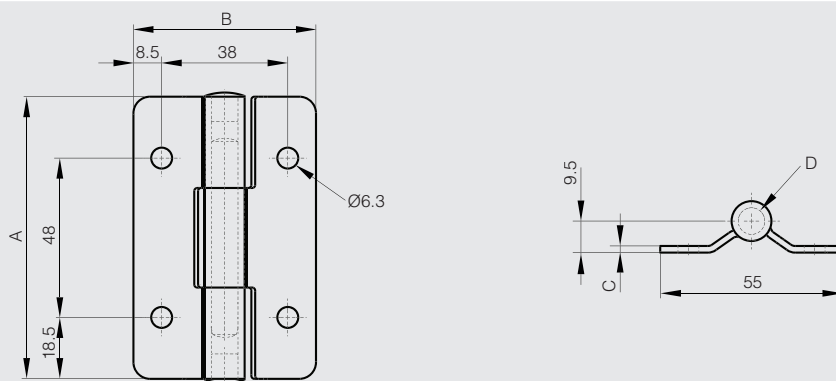



Stainless steel range - Hinges

Hinges with dual function

Stainless steel friction hinge - friction torque 1.9 N.m

Hinge with friction torque holds lid / door in desired position.

Operating temperature: -20°C / +60°C.



Part number	Material	Finish	A	B	C	Torque	Weight (g)
52-7-4048	304 stainless steel	polished	50	42.5	2	1.9 N.m	51

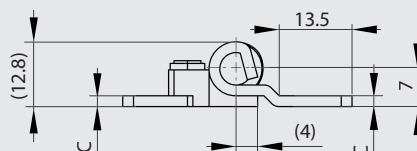
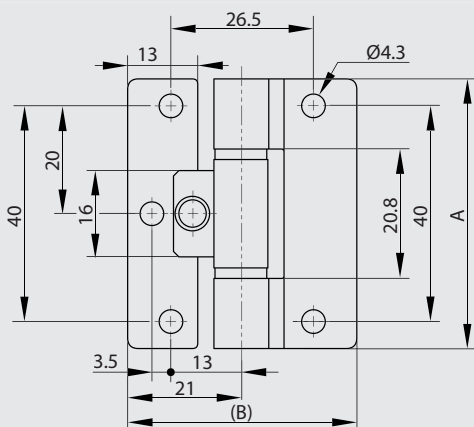

Stainless steel friction hinge - friction torque 5.8 N.m

Hinge with friction torque holds lid / door in desired position.

Operating temperature: -20°C / +60°C.



Part number	Material	Finish	A	B	C	Torque	Weight (g)
52-7-4049	304 stainless steel	polished	90	82.5	2.5	5.8 N.m	195

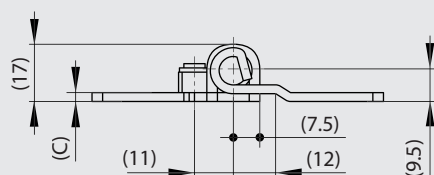
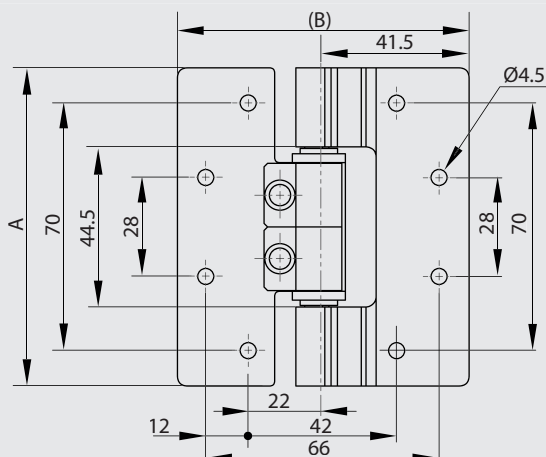



Dual axis torque hinge - 30 x 60 mm

- Dual axis: free stop at any angle in tilt & swivel.
- Provide torque stability in both directions.
- Torque per piece (tilting): 2.9 N.m.
- Torque per piece (swiveling): 1.4 N.m.
- Suitable for monitor screens.
- Rotation upon axis X can occur from 0° to 180°.
- Rotation upon axis Z can occur up to 360°.



Part number	Material	Finish	A	B	C	Torque	Weight (g)
70-7-3622	430 stainless steel	polished	30	60	51.5	2.9 N.m (axis X) / 1.4 N.m (axis Z)	92

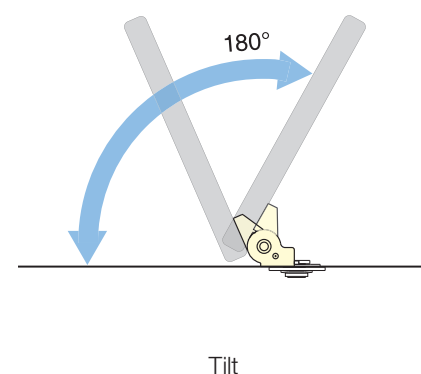
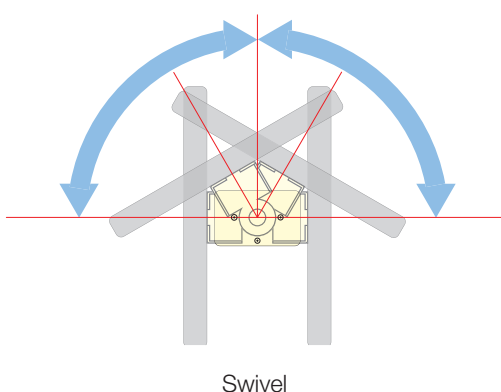
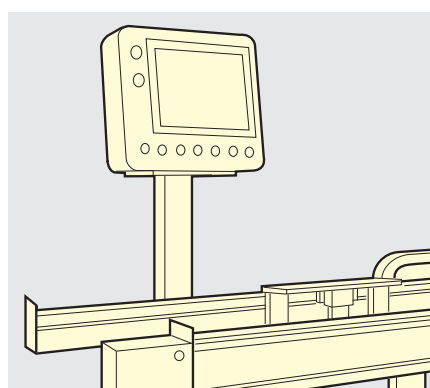
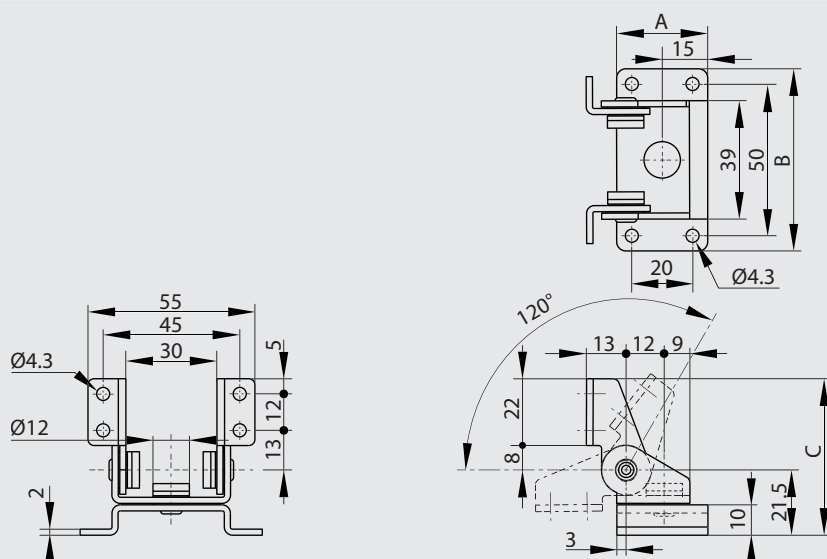



Stainless steel range - Hinges

Hinges with dual function

Dual axis torque hinge - 50 x 76 mm



- Dual axis: free stop at any angle in tilt & swivel.
- Provide torque stability in both directions.
- Torque per piece (tilting): 7 N.m.
- Torque per piece (swiveling) 3 N.m.
- Suitable for monitor screens.
- Rotation upon axis X is free but can be blocked from 0° to 120° with an additional pin.
- Rotation upon axis Z is free but can be blocked at 30° or 90° with additional pins (various holes in the fixing plate).
- Electric cables can go through a hole in the middle of the fixing plate.



Part number	Material	Finish	A	B	Torque	Weight (g)
70-7-3621	430 stainless steel	polished	50	76	7 N.m (axis X) / 3 N.m (axis Z)	232

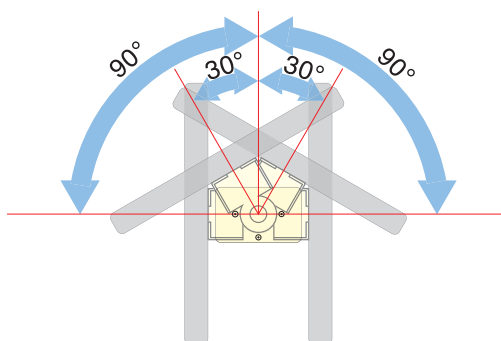
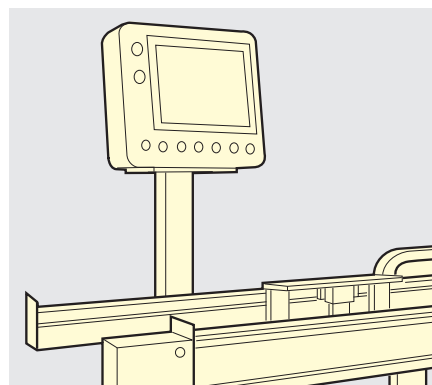
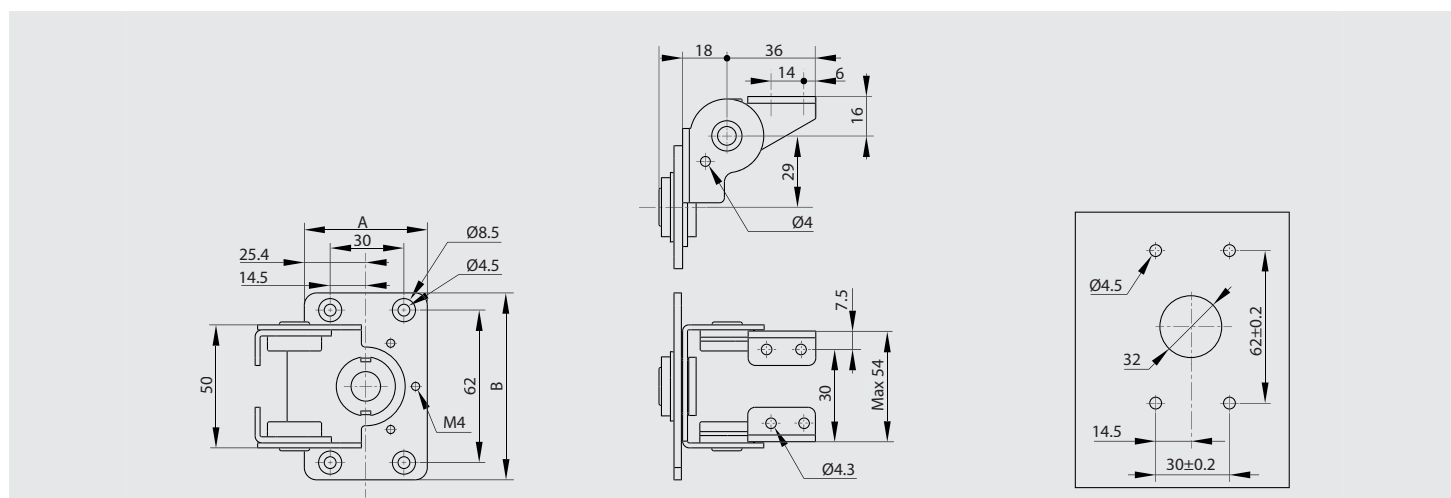

Swivel

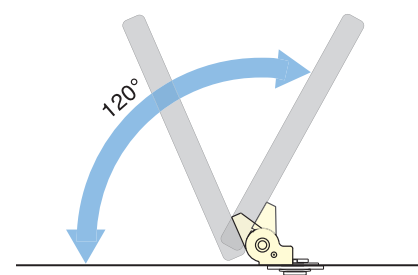

Tilt



Stainless steel range - Hinges

Hinges with dual function

Swivel torque hinge - torque 2 N.m



Rotation angle: 360°.

Friction torque: 2 N.m.

For indoor applications (industrial control panels and monitors).

	Part number	Material	Finish	A	B	Torque	Weight (g)
NEW	70-7-3636	430 stainless steel	polished	56	56	2 N.m	49

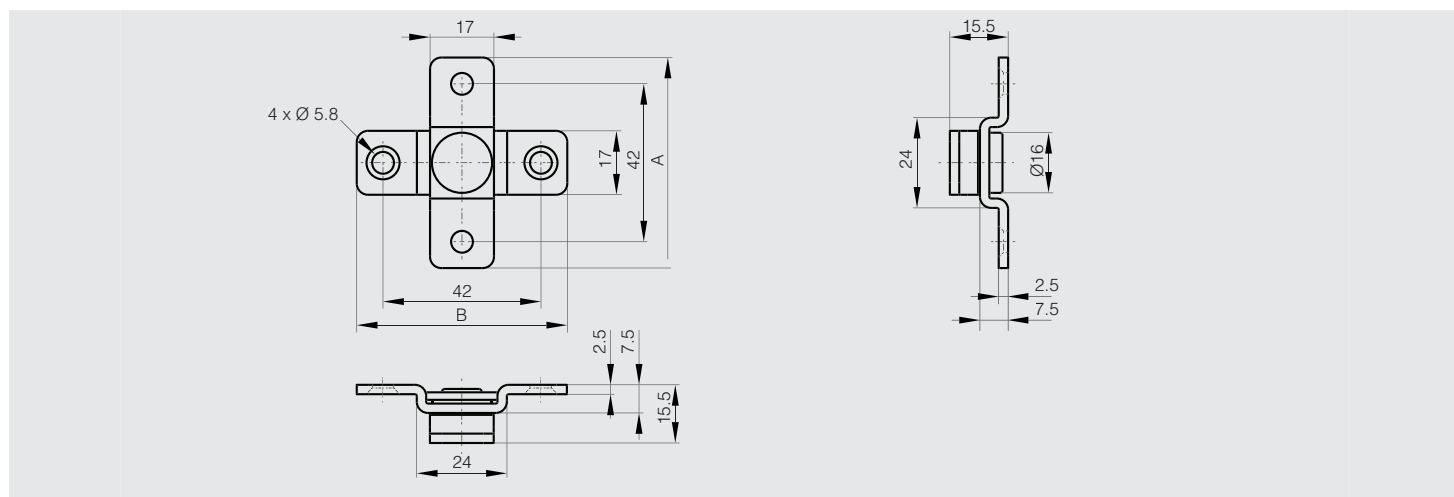

Swivel torque hinge with hole diameter 21.5 mm - torque 5 N.m



Rotation angle: 360°.

Friction torque: 5 N.m.

Center hole for easy cable management.

For indoor applications (industrial control panels and monitors).

	Part number	Material	Finish	A	B	Torque	Weight (g)
NEW	70-7-3637	430 stainless steel	polished	60	25	5 N.m	174

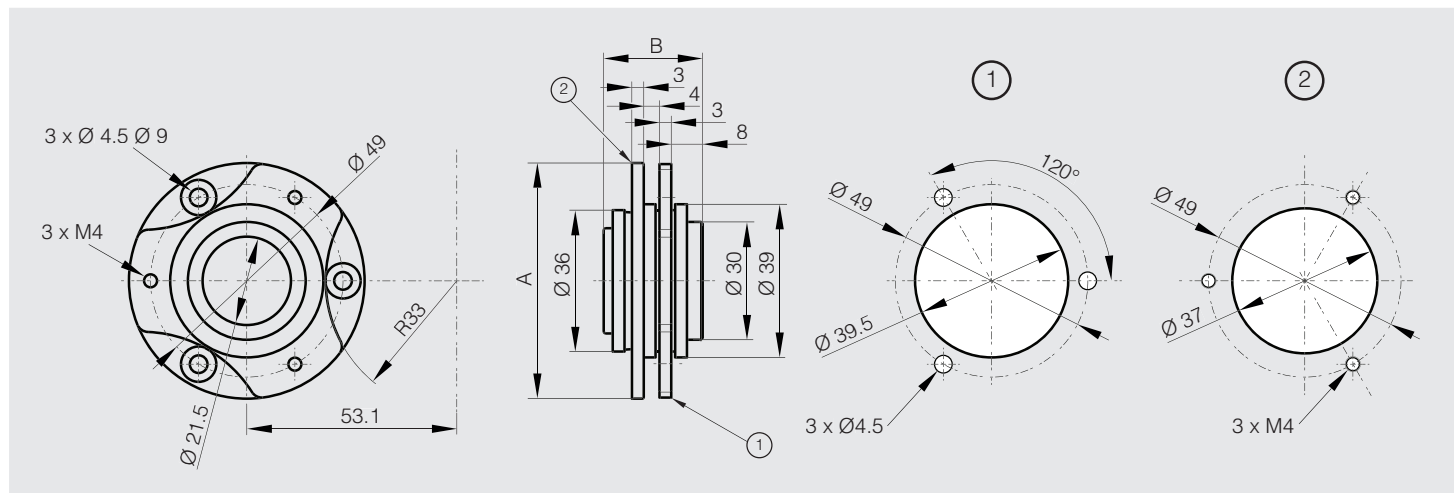



Stainless steel range - Hinges

Hinges with dual function

Swivel torque hinge with hote diameter 34 mm - torque 7 N.m



Rotation angle: 360°.

Friction torque: 7 N.m.

Center hole for easy cable management.

For indoor applications (industrial control panels and monitors).

Part number	Material	Finish	A	B	Torque	Weight (g)
NEW 70-7-3638	430 stainless steel	polished	87	20.5	7 N.m	282

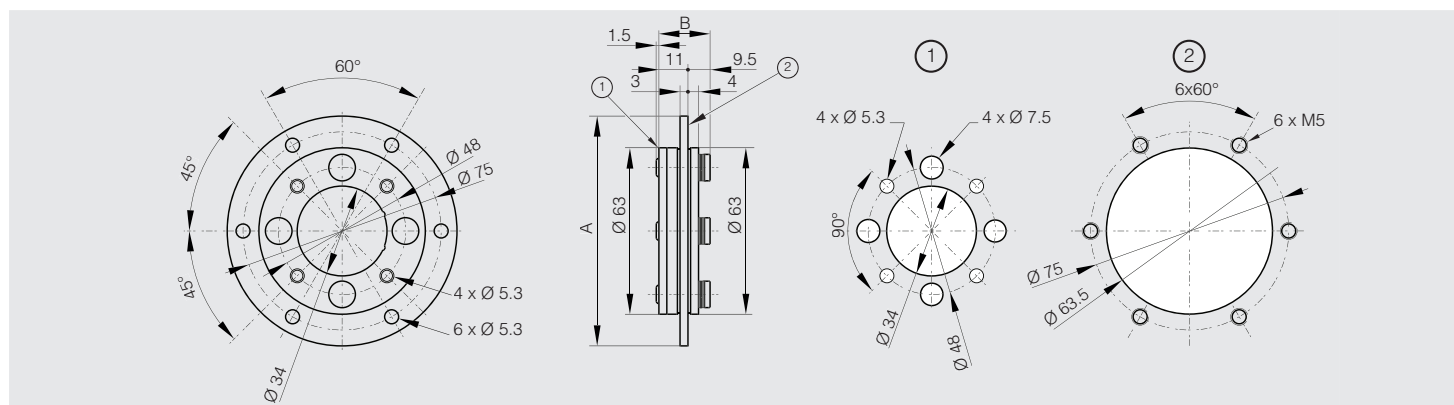

Hinge with stop at 115°



Part number	Material	Finish	A	B	C	Weight (g)
52-7-3960	304 stainless steel	polished	40	105	3	122

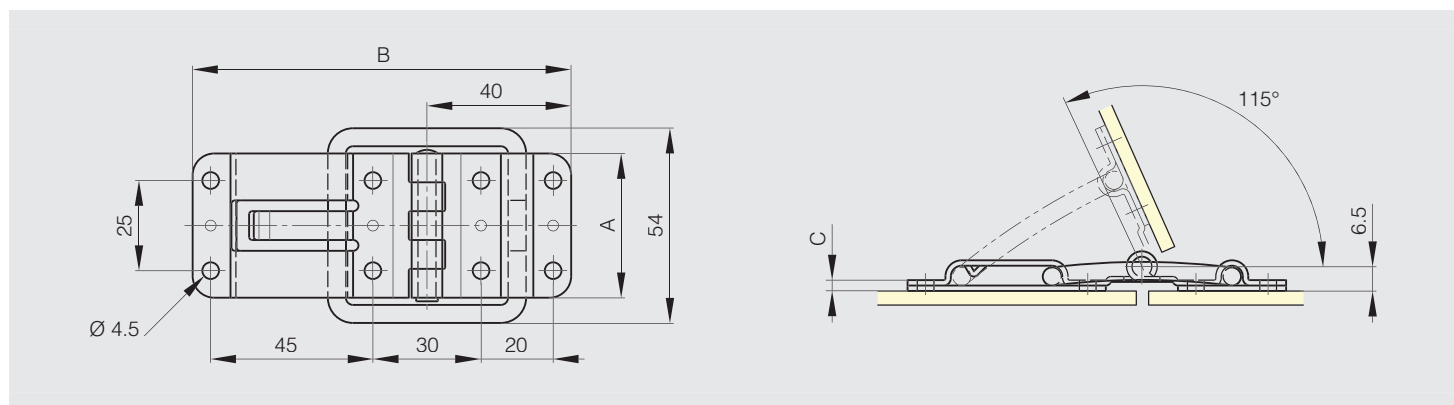



Hinge with stop at 60°

Suitable for mounting on glass doors.
For horizontal application.



Part number	Material	Finish	A	B	C	D	Weight (g)
52-1-3840	304 stainless steel	brightened	35	133	2.5	6	140

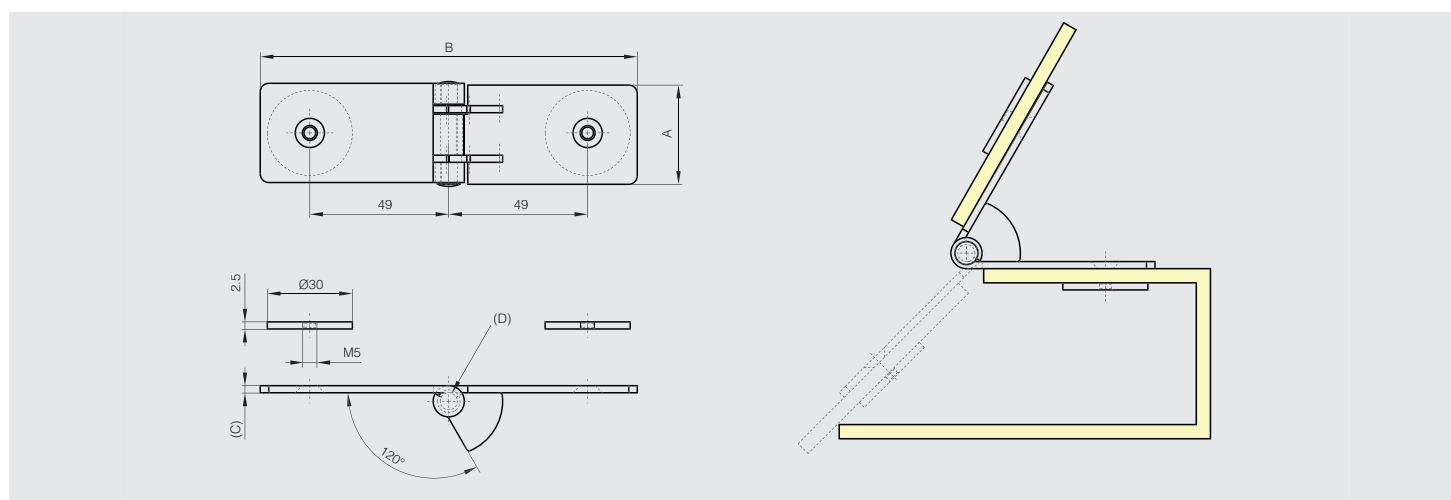



Soft-close dampening hinge in stainless steel



- Soft-close dampening hinge: soft-close damper keeps lid from slamming shut when the hinge is put in the closed position.
- Damper working direction: shown by the arrow in the drawing.
- Operating angle: 115°.
- If the opening angle is wider than 115° (+/- 5°), mechanism is broken and damper doesn't work anylonger.
- **Provide a door stopper to prevent from overturning beyond the prescribed angle range.**
- Do not force the door to close faster in damper effective direction. It can cause damage to the product.
- When the door opening angle is small, the dampers may not work smoothly.
- Torque moment (for one hinge): 2.2 to 3.0 N.m.
- Torque calculation:
 - L = door height in metre.
 - W = door weight in kilo.
- Operating temperature: 0 to + 40°C.
- Soft close of a door (vertical application): door closing system.

A similar hinge with a spring can be used: put together with a dampening hinge, an automatic soft close of a door is possible without any other component.

Please ask us for more information.



Part number	Material	Finish	A	B	C	D	Torque	Note	Weight (g)
75-1-0003	304 stainless steel	raw	80	40	3	16	2.2 - 3.0 N.m	Damper working direction when closing the hinge	300

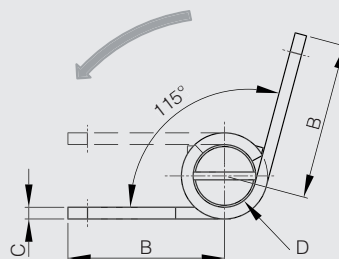
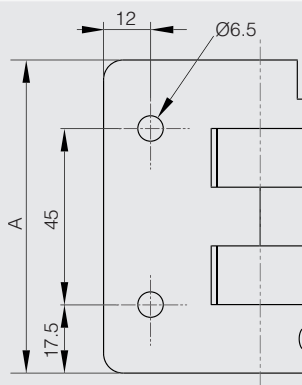



Forged hinges - 3 knuckles



Riveted pin.

Other dimensions or variants are available on request.

304 stainless steel pin for 304 stainless steel hinges.

Part number	Material	Finish	A	B	C	D	E	Note	Weight (g)
72-1-3990	304 stainless steel	raw	50	50	3	4	4	4 MR (railway code)	71
NEW 72-1-4186	304 stainless steel	raw	50	80	3	4	4	6 MR (railway code)	112
72-1-4187	304 stainless steel	raw	50	80	5	6	6	9 MR (railway code)	182

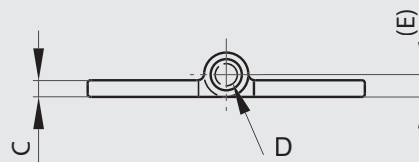
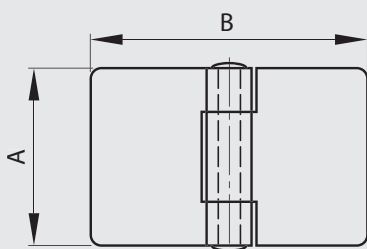

Forged hinges with reversed leaves - 3 knuckles



Riveted pin.

Other dimensions or variants are available on request.

304 stainless steel pin for 304 stainless steel hinges.

Part number	Material	Finish	A	B	C	D	E	Note	Weight (g)
72-1-3992	304 stainless steel	raw	50	50	3	4	4	20 MR (railway code)	71
72-1-3993	304 stainless steel	raw	50	80	3	4	4	22 MR (railway code)	112

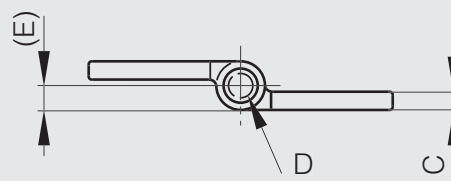
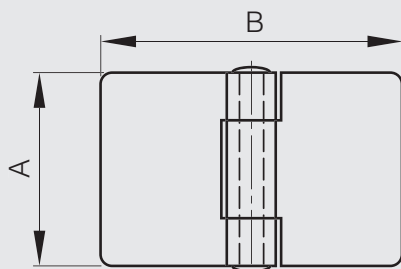



Forged hinges - 5 knuckles



Riveted pin: (except part number: 72-1-4288 with a removal pin).

Other dimensions or variants are available on request.

304 stainless steel pin for 304 stainless steel hinges.



Part number	Material	Finish	A	B	C	D	E	Note	Weight (g)
NEW 72-1-4290	304 stainless steel	raw	60	60	6	6	6		283
72-1-3991	304 stainless steel	raw	80	80	5	6	6	1 FR (railway code)	283
NEW 72-1-4279	304 stainless steel	raw	80	130	5	6	6	3 FR (railway code)	436
NEW 72-1-4288	304 stainless steel	raw	80	130	5	6	6	Removable pin	436

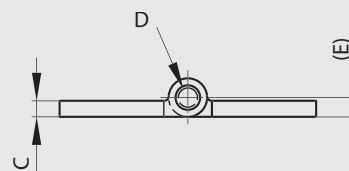
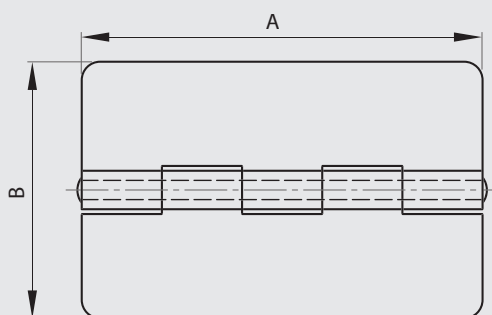

Heavy duty pin hinges

With chamfered edges.



Part number	Material	Finish	A	B	C	D	E	F	H	S	Weight (g)
12-7-3810	303 stainless steel	brushed	64	13	16	6	16	16	9.5	M5x6	90
12-7-3811	303 stainless steel	brushed	76	13	19	6	19	18	13	M6x7.5	130

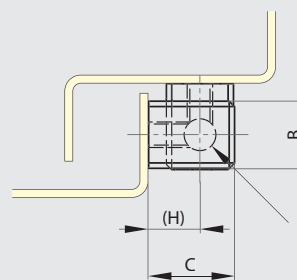
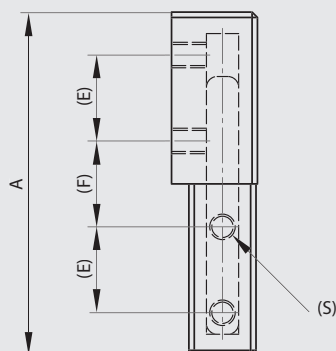



Half leaves for Modulo hinges - thickness 3 mm

Leaves can be combined together and with either:

- a 6 mm diameter expanded pin (BG) (part numbers 27-1-3820, 27-1-3823),
- a 6 mm pin in POM (part number 27-1-3938),
- a 6 mm diameter headed pin (BT) (part numbers 27-1-3826, 27-1-3829) with a plug (part numbers 27-1-3832, 27-1-3835).



Part number	Material	Finish	A	B	C	D	Weight (g)
52-1-3771	304 stainless steel	deburred	80	30	3	6	74
52-1-3772	304 stainless steel	deburred	80	40	3	6	92.5
52-1-3773	304 stainless steel	deburred	80	50	3	6	111.4
52-1-3774	304 stainless steel	deburred	80	60	3	6	130.2
52-1-3775	304 stainless steel	deburred	80	80	3	6	168



Half leaves for Modulo hinges - thickness 4 mm

Leaves can be combined together and with either:

- a 8 mm diameter expanded pin (BG) (part numbers 27-1-3821, 27-1-3824),
- a 8 mm diameter headed pin (BT) (part numbers 27-1-3827, 27-1-3830) with a plug (part numbers 27-1-3833, 27-1-3836).



Part number	Material	Finish	A	B	C	D	Weight (g)
52-1-3776	304 stainless steel	deburred	100	30	4	8	131
52-1-3777	304 stainless steel	deburred	100	40	4	8	162.5
52-1-3778	304 stainless steel	deburred	100	50	4	8	194
52-1-3779	304 stainless steel	deburred	100	60	4	8	225.3
52-1-3780	304 stainless steel	deburred	100	80	4	8	288



Half leaves for Modulo hinges - thickness 5 mm

Leaves can be combined together and with either:

- a 10 mm diameter expanded pin (BG) (part numbers 27-1-3822, 27-1-3825),
- a 10 mm diameter headed pin (BT) (part numbers 27-1-3828, 27-1-3831) with a plug (part numbers 27-1-3834, 27-1-3837).



Part number	Material	Finish	A	B	C	D	Weight (g)
52-1-3781	304 stainless steel	deburred	120	30	5	10	211
52-1-3782	304 stainless steel	deburred	120	40	5	10	258
52-1-3783	304 stainless steel	deburred	120	50	5	10	305.2
52-1-3784	304 stainless steel	deburred	120	60	5	10	352.3
52-1-3785	304 stainless steel	deburred	120	80	5	10	446.5

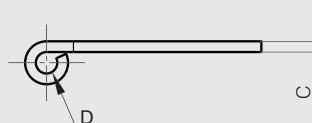
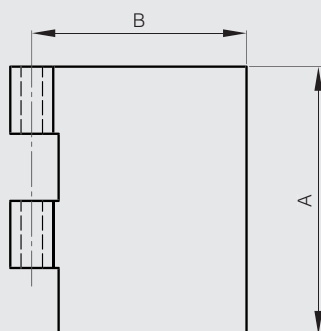



Half leaves for Modulo pin hinges - thickness 3 mm

Leaves can be combined together and with either:

- a 6 mm diameter expanded pin (BG) (part numbers 27-1-3820, 27-1-3823),
- a 6 mm pin in POM (part number 27-1-3938),
- a 6 mm diameter headed pin (BT) (part numbers 27-1-3826, 27-1-3829) with a plug (part numbers 27-1-3832, 27-1-3835).



Part number	Material	Finish	A	B	C	D	Weight (g)
12-1-3869	304 stainless steel	deburred	40	30	3	6	36.9
12-1-3870	304 stainless steel	deburred	40	50	3	6	55.7
12-1-3871	304 stainless steel	deburred	40	80	3	6	84
12-1-3942	304 stainless steel	deburred	40	20	3	6	24.6
12-1-3944	304 stainless steel	deburred	40	120	3	6	126



Half leaves for Modulo pin hinges - thickness 4 mm

Leaves can be combined together and with either:

- a 8 mm diameter expanded pin (BG) (part numbers 27-1-3821, 27-1-3824),
- a 8 mm diameter headed pin (BT) (part numbers 27-1-3827, 27-1-3830) with a plug (part numbers 27-1-3833, 27-1-3836).



Part number	Material	Finish	A	B	C	D	Weight (g)
12-1-3875	304 stainless steel	deburred	50	30	4	8	65.6
12-1-3876	304 stainless steel	deburred	50	50	4	8	97
12-1-3877	304 stainless steel	deburred	50	80	4	8	144



Half leaves for Modulo pin hinges - thickness 5 mm

Leaves can be combined together and with either:

- a 10 mm diameter expanded pin (BG) (part numbers 27-1-3822, 27-1-3825),
- a 10 mm diameter headed pin (BT) (part numbers 27-1-3828, 27-1-3831) with a plug (part numbers 27-1-3834, 27-1-3837).



Part number	Material	Finish	A	B	C	D	Weight (g)
12-1-3881	304 stainless steel	deburred	60	40	5	10	129
12-1-3882	304 stainless steel	deburred	60	60	5	10	176.2
12-1-3883	304 stainless steel	deburred	60	80	5	10	224

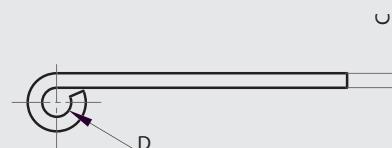
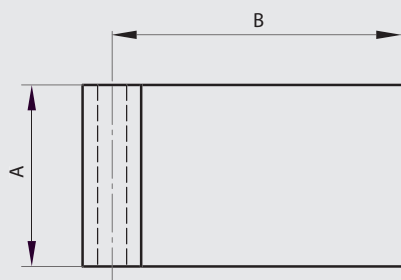



Expanded pin BG for Modulo system

This pin alone enables you to make a hinge pin for Modulo hinges.



Part number	Material	Finish	D	L	Weight (g)
27-1-3823	304 stainless steel	raw	6	80	17.7
27-1-3824	304 stainless steel	raw	8	100	39.4
27-1-3825	304 stainless steel	raw	10	120	74

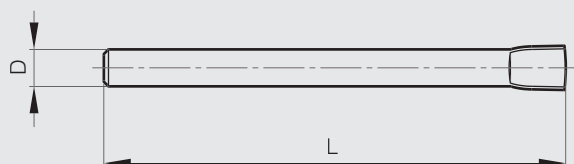

BG Broche Gonflée
Expanded pin
Gestauchter Stift

Headed pin BT for Modulo system

This pin combined with a plug (VA) enables you to make a hinge pin for Modulo hinges.



Part number	Material	Finish	D	E	L	Weight (g)
27-1-3829	304 stainless steel	raw	6	3	66	15.5
27-1-3830	304 stainless steel	raw	8	4	86	35.5
27-1-3831	304 stainless steel	raw	10	5	106	68.4



Plug (VA) for Modulo system

This plug combined with a headed pin (BT) enables you to make a hinge pin for Modulo hinges.



Part number	Material	Finish	D	F	L	Weight (g)
27-1-3835	304 stainless steel	raw	6	12	12	3.3
27-1-3836	304 stainless steel	raw	8	16	12	6.3
27-1-3837	304 stainless steel	raw	10	20	12	10.5

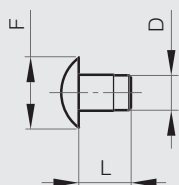

VA Vase
Plug
Stopfen

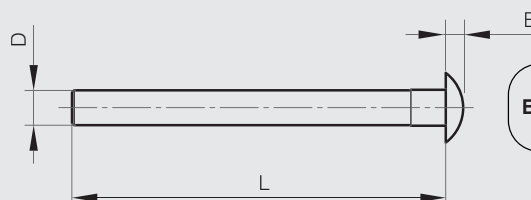

BT Broche à Tête
Headed pin
Stift mit Kopf



Heavy duty hinges

Heavy duty hinges - 65 x 230 mm

Riveted pin.



Part number	Material	Finish	A	B	C	D	E	S	Note	Weight (g)
52-1-3553	304 stainless steel	brightened	65	230	4	10	39	6.5	drilled	430
52-1-3593	304 stainless steel	brightened	65	230	4	10	39		undrilled	450

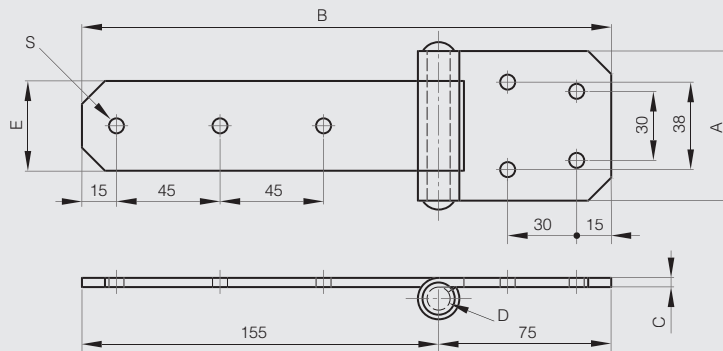

Flat top weld-on stainless steel hinges - stainless steel pin - brass washer

Fixed pin and washer.



Part number	Material	Finish	A	B	C	D	Weight (g)
14-7-3693	304 stainless steel	raw	60	12	10	6	40
14-7-3696	304 stainless steel	raw	80	16	13	7	90
14-7-3697	304 stainless steel	raw	100	20	16	9	115
14-7-3698	304 stainless steel	raw	120	20	16	9	135

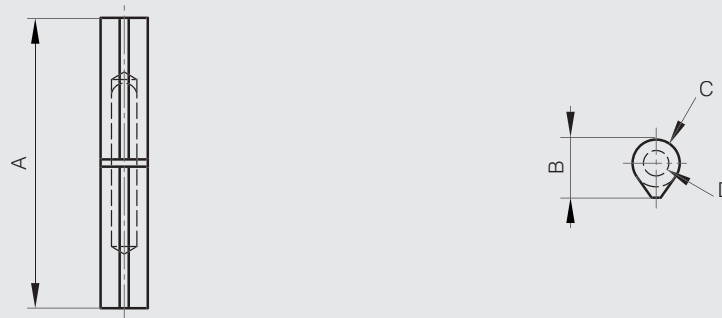



Square hinges with two offset leaves and removable pin - with 4 holes

Removable pin.



Part number	Material	Finish	A	B	C	D	F	G	S	Weight (g)
52-1-3608	304 stainless steel	raw	40	40	2	4	8	24	4	34
52-1-3610	304 stainless steel	raw	50	50	2	6	8	34	4.5	61
52-1-3612	304 stainless steel	raw	60	60	2	6	8	40	4.5	82

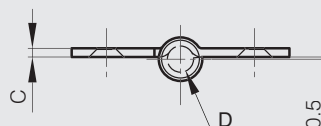
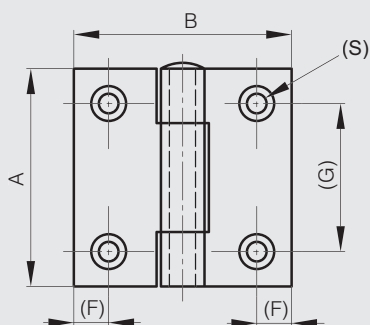

Square hinges with two offset leaves and removable pin - with 6 holes

Removable pin.



Part number	Material	Finish	A	B	C	D	F	G	H	S	Weight (g)
52-1-3614	304 stainless steel	raw	70	70	2	6	8	50	10	4.5	156
52-1-3616	304 stainless steel	raw	80	80	2.5	6	8	60	12.5	4.5	164

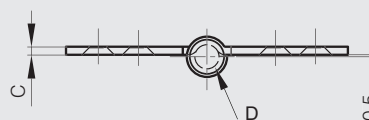
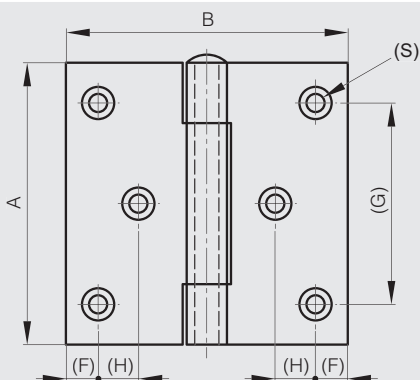



Square hinges with two offset leaves and riveted pin - with 4 holes

Riveted pin.



Part number	Material	Finish	A	B	C	D	F	G	S	Weight (g)
52-1-3609	304 stainless steel	raw	40	40	2	4	8	24	4	34
52-1-3611	304 stainless steel	raw	50	50	2	6	8	34	4.5	61
52-1-3613	304 stainless steel	raw	60	60	2	6	8	40	4.5	82
52-1-3872	316L stainless steel	raw	40	40	2	4	8	24	4	34
52-1-3709	316L stainless steel	raw	50	50	2	6	8	34	4.5	61
52-1-3873	316L stainless steel	raw	60	60	2	6	8	40	4.5	82

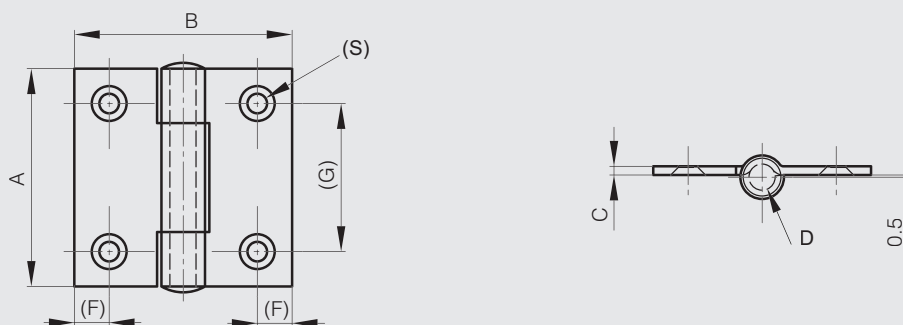

Square hinges with two offset leaves and riveted pin - with 6 holes

Riveted pin.



Part number	Material	Finish	A	B	C	D	F	G	H	S	Weight (g)
52-1-3615	304 stainless steel	raw	70	70	2	6	8	50	10	4.5	156
52-1-3617	304 stainless steel	raw	80	80	2.5	6	8	60	12.5	4.5	164

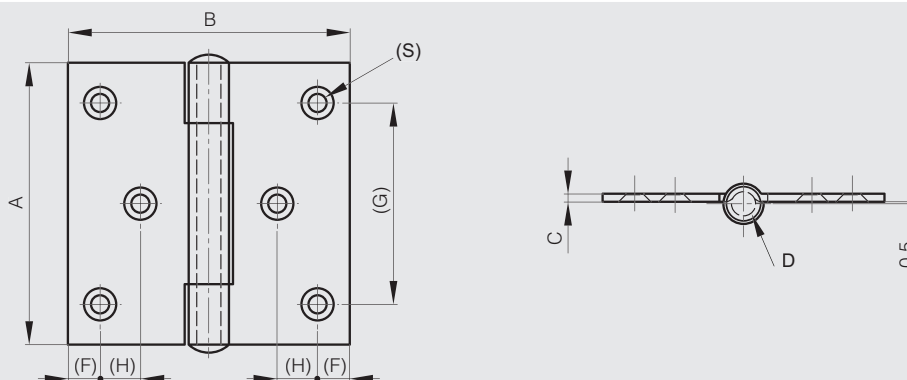



Square hinges with no offset leaf and riveted pin - no holes

Riveted pin.



Part number	Material	Finish	A	B	C	D	Weight (g)
52-1-3679	304 stainless steel	raw	40	40	2	4	34
52-1-3694	304 stainless steel	raw	50	50	2	6	61
52-1-3695	304 stainless steel	raw	60	60	2	6	82
52-1-3864	304 stainless steel	raw	70	70	2	6	112
52-1-3865	304 stainless steel	raw	80	80	2.5	6	168
52-1-3866	304 stainless steel	raw	100	100	2.5	6	248
52-1-3869	316L stainless steel	raw	40	40	2	4	34
52-1-3870	316L stainless steel	raw	50	50	2	6	61
52-1-3871	316L stainless steel	raw	60	60	2	6	82

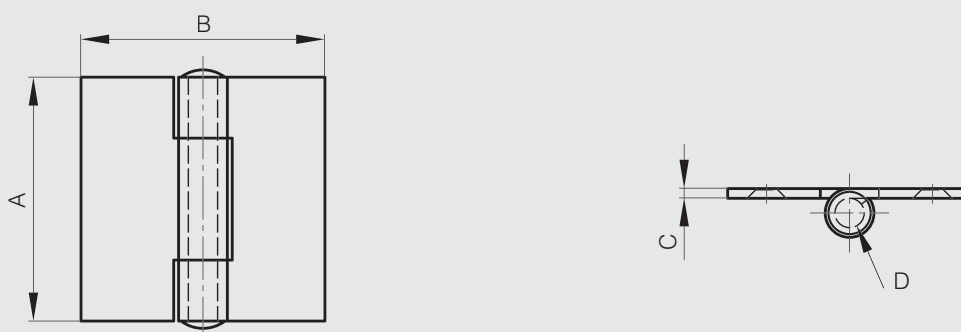

Square hinges with no offset leaf and riveted pin - with 4 holes

Riveted pin.



Part number	Material	Finish	A	B	C	D	F	G	S	Weight (g)
52-1-3861	304 stainless steel	raw	40	40	2	4	8	24	4	32
52-1-3862	304 stainless steel	raw	50	50	2	6	8	34	4.5	59
52-1-3863	304 stainless steel	raw	60	60	2	6	8	40	4.5	80
52-1-3874	316L stainless steel	raw	40	40	2	4	8	24	4	32
52-1-3710	316L stainless steel	raw	50	50	2	6	8	34	4.5	59
52-1-3875	316L stainless steel	raw	60	60	2	6	8	40	4.5	80

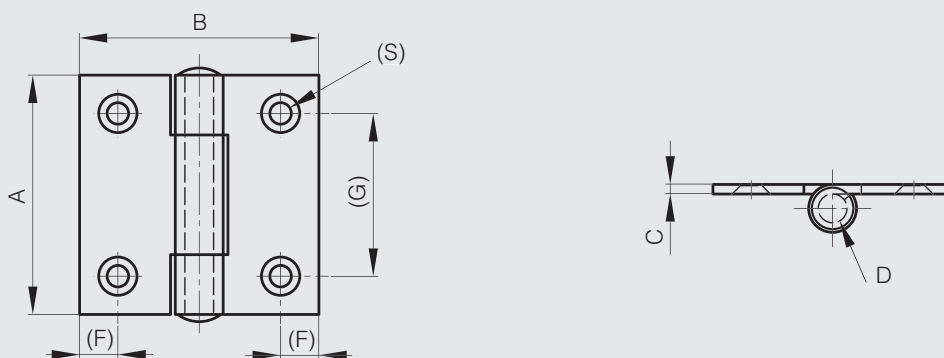



Common hinges

Square hinges with no offset leaf and riveted pin - with 6 holes

Riveted pin.



Part number	Material	Finish	A	B	C	D	F	G	H	S	Weight (g)
52-1-3867	304 stainless steel	raw	70	70	2	6	8	50	10	4.5	110
52-1-3868	304 stainless steel	raw	80	80	2.5	6	8	60	12.5	4.5	166

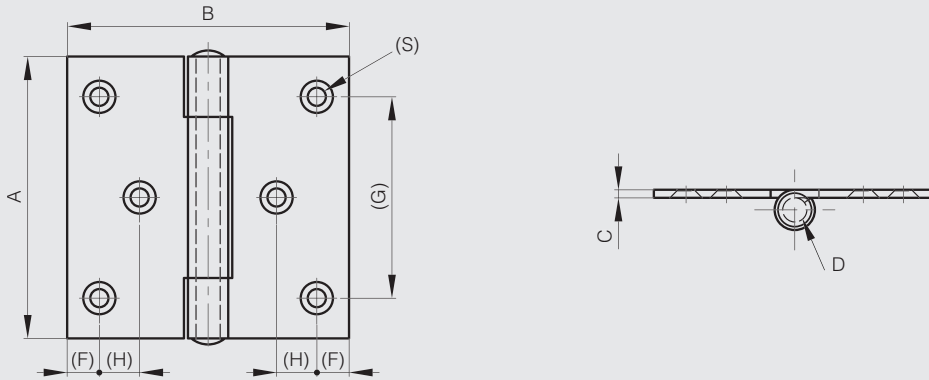

Hinge 30 x 30 mm



Part number	Material	Finish	A	B	C	D	S	Weight (g)
52-1-4038	304 stainless steel	raw	30	30	0.8	2	3.3	8

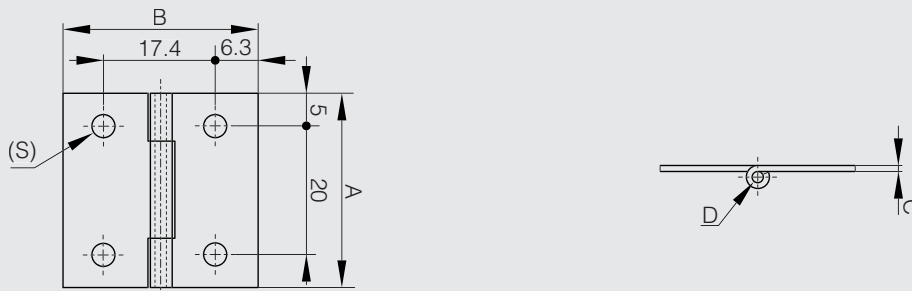



Hinge with nylon washers

Teflon plated pin in 304 stainless steel blocked with 2 punches.
4 nylon washers.



Part number	Material	Finish	A	B	C	D	E	F	G	S	Weight (g)
52-1-3790	304 stainless steel	raw	75	80	2	6	10.5	6	52	7.5	120

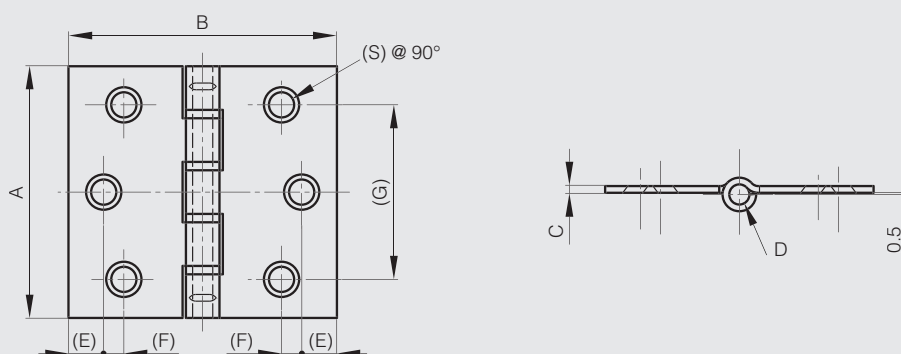

Hinge 50 x 30 mm

Drilled hinge with riveted pin.



Part number	Material	Finish	A	B	C	D	F	G	S	Weight (g)
52-1-3571	304 stainless steel	raw	50	30	1	3	6.5	35	3.5	16

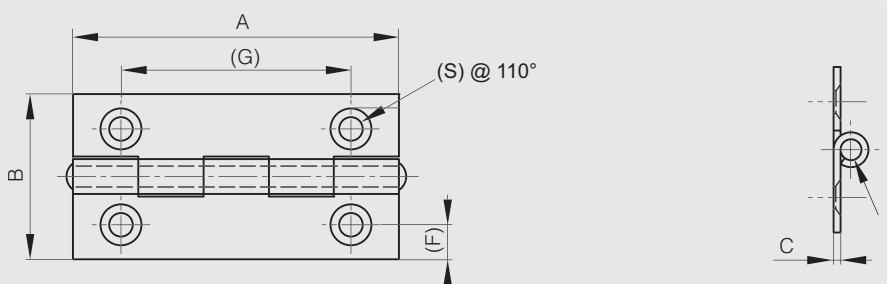



Hinges 50 x 40 mm

Available in 2 versions: with holes or countersunk holes



Part number	Material	Finish	A	B	C	D	F	G	S	Note	Weight (g)
52-1-3592	304 stainless steel	raw	50	40	1.2	3	8.5	36	5	countersunk version	24
52-1-3607	304 stainless steel	raw	50	40	1.2	3	8.5	36	5	drilled	24

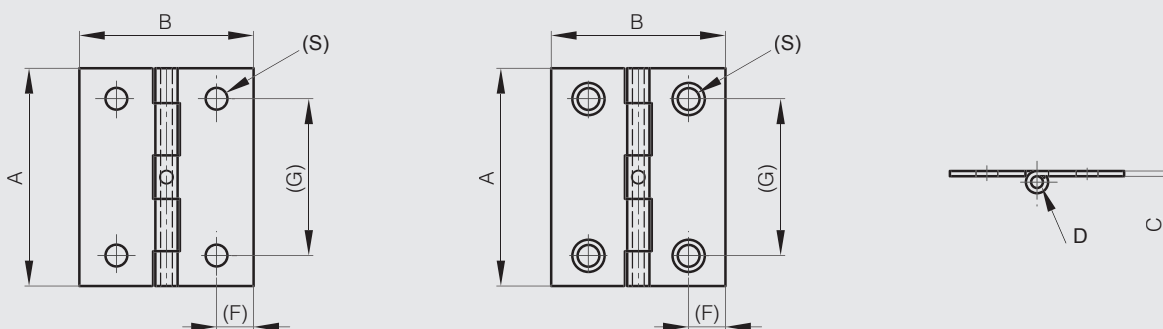

Hinges 60 x 35 mm



Part number	Material	Finish	A	B	C	D	S	Note	Weight (g)
52-1-4009	304 stainless steel	raw	60	35	1	2	4	countersunk version	20
52-1-4051	304 stainless steel	raw	60	35	1	2	4	drilled	20

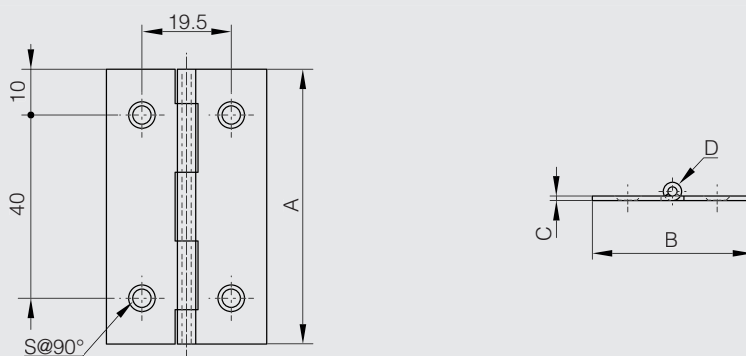



Common hinges

Hinge 75 x 40 mm



Part number	Material	Finish	A	B	C	D	E	F	G	Weight (g)
52-1-3990	304 stainless steel	raw	75	40	1.5	3	6	7.5	48	40

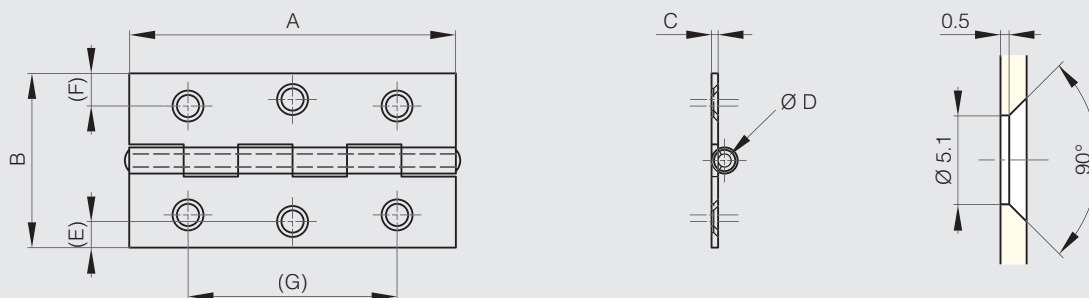

Lift-off hinges 80 x 60 mm - stainless steel

Pin and washer in stainless steel.



Part number	Material	Finish	A	B	C	D	S	Note	Weight (g)
14-1-3872	304 stainless steel	raw	80	60	2	6	6.3	type 1	115
14-1-3873	304 stainless steel	raw	80	60	2	6	6.3	type 2	115

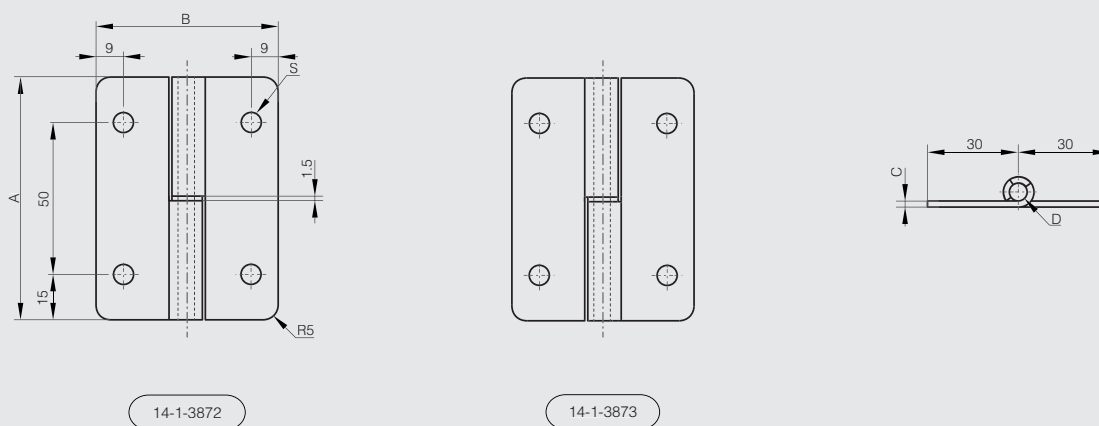



Common hinges

Lift-off hinges 80 x 80 mm - stainless steel with 6 holes

2 shapes available:

- Shape with square ends (14-7-3727 and 14-7-3728).
- Shape with round ends (14-7-3729 and 14-7-3730).

Only the visible side has a brushed finish.



Part number	Material	Finish	A	B	C	D	S	Note	Weight (g)
14-7-3727	304 stainless steel	brushed	80	80	2.5	7	5.2	type 1 / square corners	175
14-7-3728	304 stainless steel	brushed	80	80	2.5	7	5.2	type 2 / square corners	175
14-7-3729	304 stainless steel	brushed	80	80	2.5	7	5.2	type 1 / round corners	175
14-7-3730	304 stainless steel	brushed	80	80	2.5	7	5.2	type 2 / round corners	175

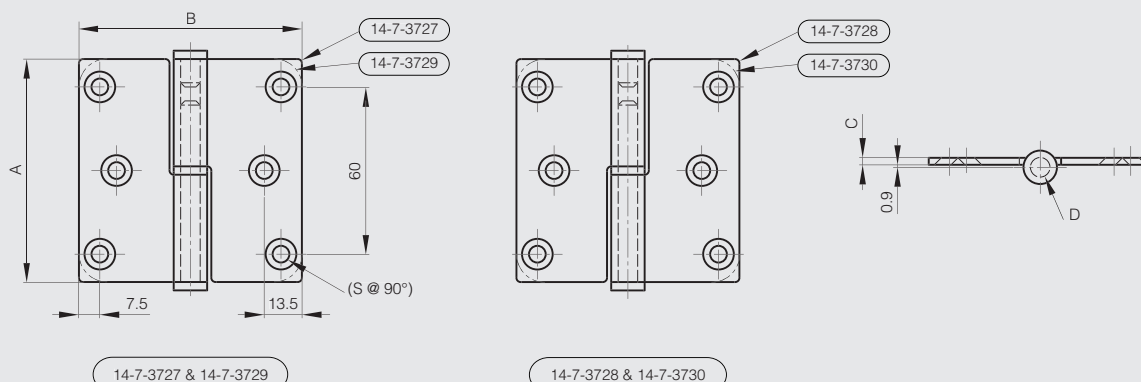

Lift-off hinges 100 x 82 mm - stainless steel with 8 holes

2 shapes available:

- Shape with square ends (14-7-3675 and 14-7-3679).
- Shape with round ends (14-7-3677 and 14-7-3681).

Only the visible side has a brushed finish.



Part number	Material	Finish	A	B	C	D	S	Note	Weight (g)
14-7-3675	304 stainless steel	brushed	100	82	2.5	7	4.7	type 1 / square corners	220
14-7-3677	304 stainless steel	brushed	100	82	2.5	7	4.7	type 1 / round corners	220
14-7-3679	304 stainless steel	brushed	100	82	2.5	7	4.7	type 2 / square corners	220
14-7-3681	304 stainless steel	brushed	100	82	2.5	7	4.7	type 2 / round corners	220

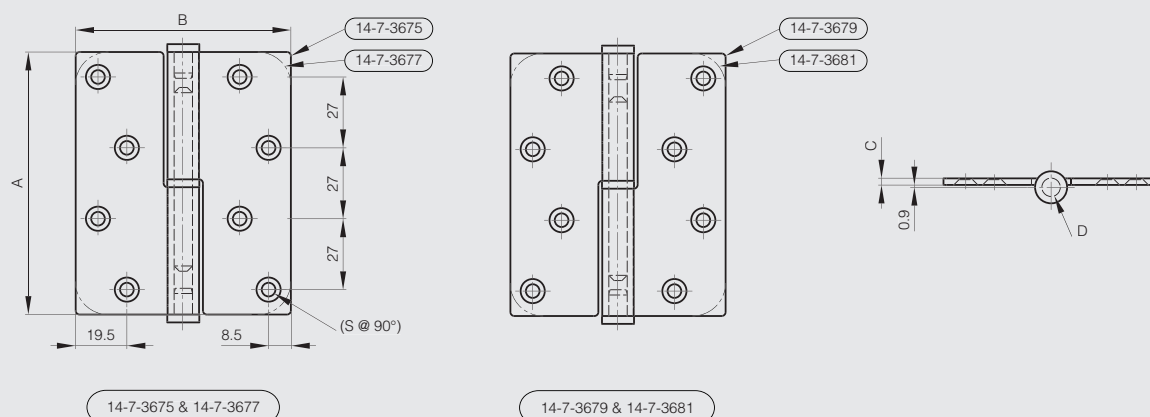



Hinge for marine applications - 36.5 x 38 mm

Riveted pin.



Part number	Material	Finish	A	B	C	D	S	Weight (g)
52-1-3945	316 stainless steel	polished	36.5	38	2	5	6	32

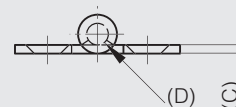
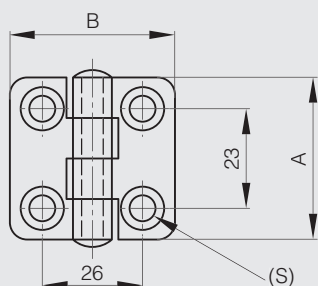

Hinge for marine applications - 36.5 x 56.5 mm

Riveted pin.



Part number	Material	Finish	A	B	C	D	S	Weight (g)
52-1-3947	316 stainless steel	polished	36.5	56.5	2	5	6	40

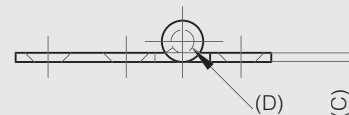
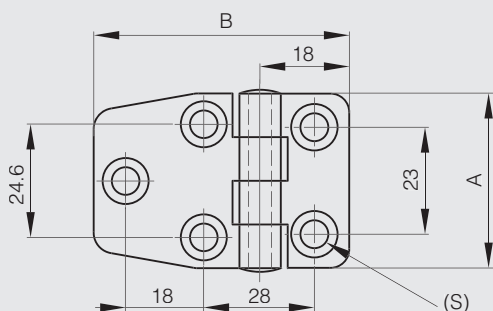



Hinge for marine applications - 36.5 x 76 mm

Riveted pin.



Part number	Material	Finish	A	B	C	D	S	Weight (g)
52-1-3944	316 stainless steel	polished	36.5	76	2	4	6	50

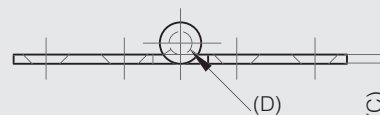
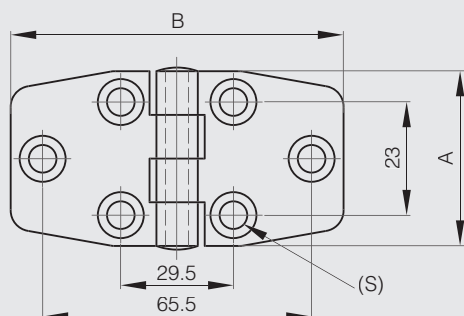

Hinges for marine applications - 36.5 x 65.5 mm

Riveted pin.



Part number	Material	Finish	A	B	C	D	E	S	Weight (g)
52-1-3950	316 stainless steel	polished	36.5	65.5	2	5	10	6	54
52-1-3949	316 stainless steel	polished	36.5	65.5	2	5	15.9	6	54
52-1-3948	316 stainless steel	polished	36.5	65.5	2	5	19.2	6	54

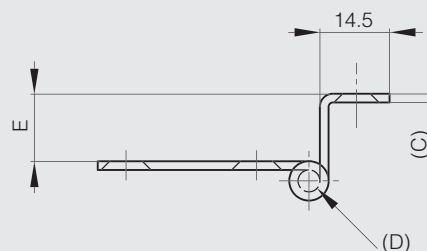
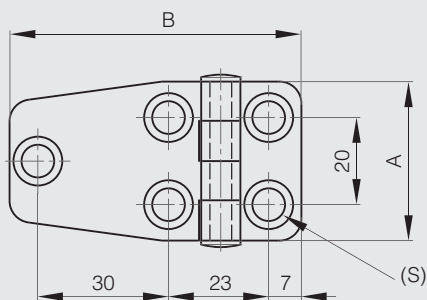



Hinge for marine applications - 38.1 x 71.1 mm



Part number	Material	Finish	A	B	C	D	S	Weight (g)
52-1-3898	316 stainless steel	polished	38.1	71.1	2	3	6	42

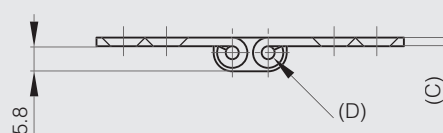
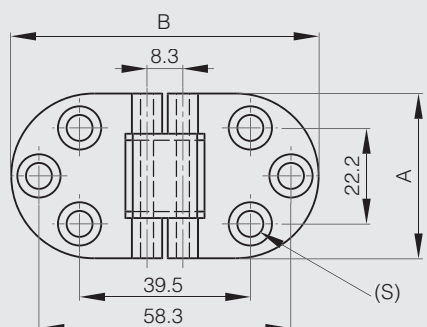

Hinge for marine applications - 52 x 70 mm

Riveted pin.



Part number	Material	Finish	A	B	C	D	S	Weight (g)
52-1-3964	316 stainless steel	brushed	52	70	1.2	4	5.2	44

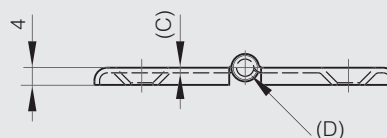
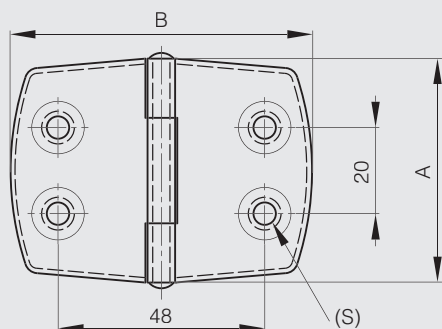



Hinge for marine applications - 30 x 101 mm

Riveted pin.



Part number	Material	Finish	A	B	C	D	S	Weight (g)
52-1-3954	316 stainless steel	polished	30	101	2	5	6	44

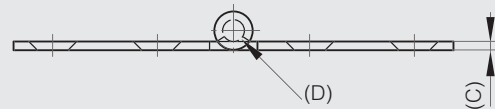
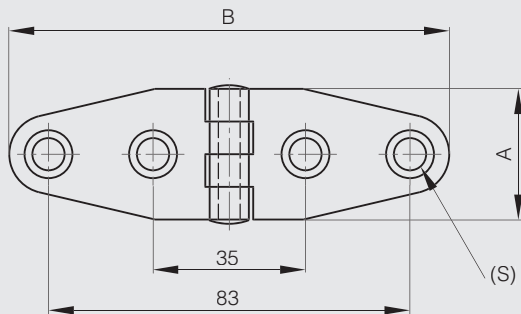

Hinge for marine applications - 38 x 178 mm

Riveted pin.



Part number	Material	Finish	A	B	C	D	S	Weight (g)
52-1-3957	316 stainless steel	polished	38	178	2	5	6	96

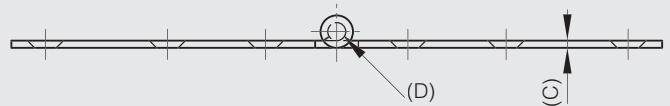
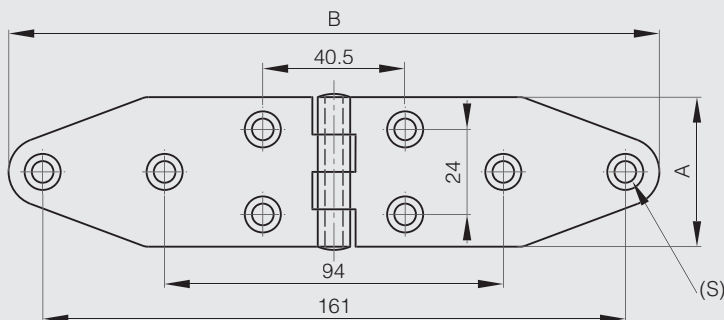



Hinge for marine applications - 40.1 x 137.3 mm

Riveted pin.



Part number	Material	Finish	A	B	C	D	S	Weight (g)
52-1-3953	316 stainless steel	polished	40.1	137.3	2	5	6	80

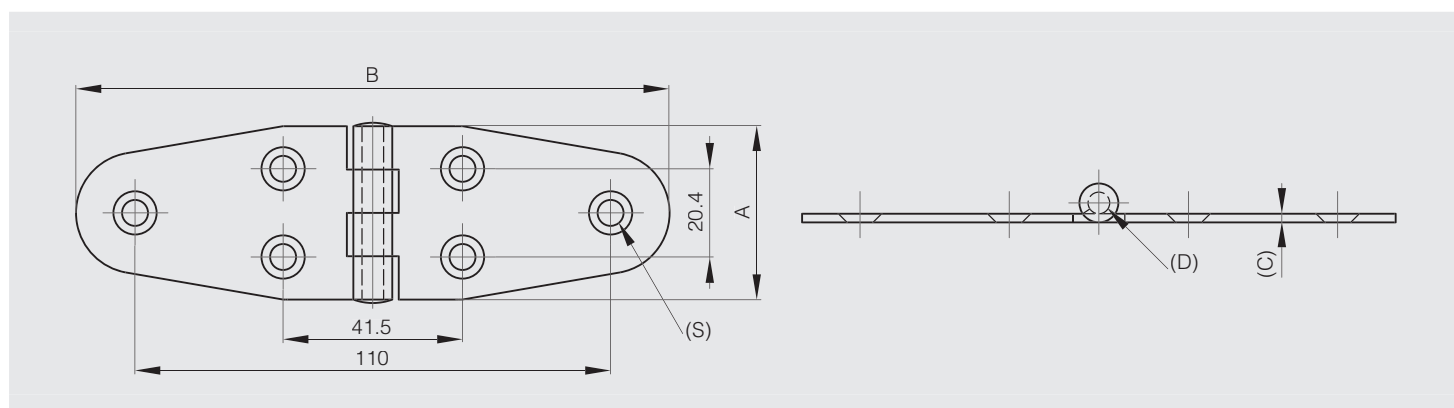

Small butt hinges with one cranked leaf 38 mm



Part number	Material	Finish	A	B	C	D	E	F	G	S	Pin material	Weight (g)
62-1-3628	316L stainless steel	raw	38	15	1.5	3	14	31	17	4.5	316L stainless steel	24

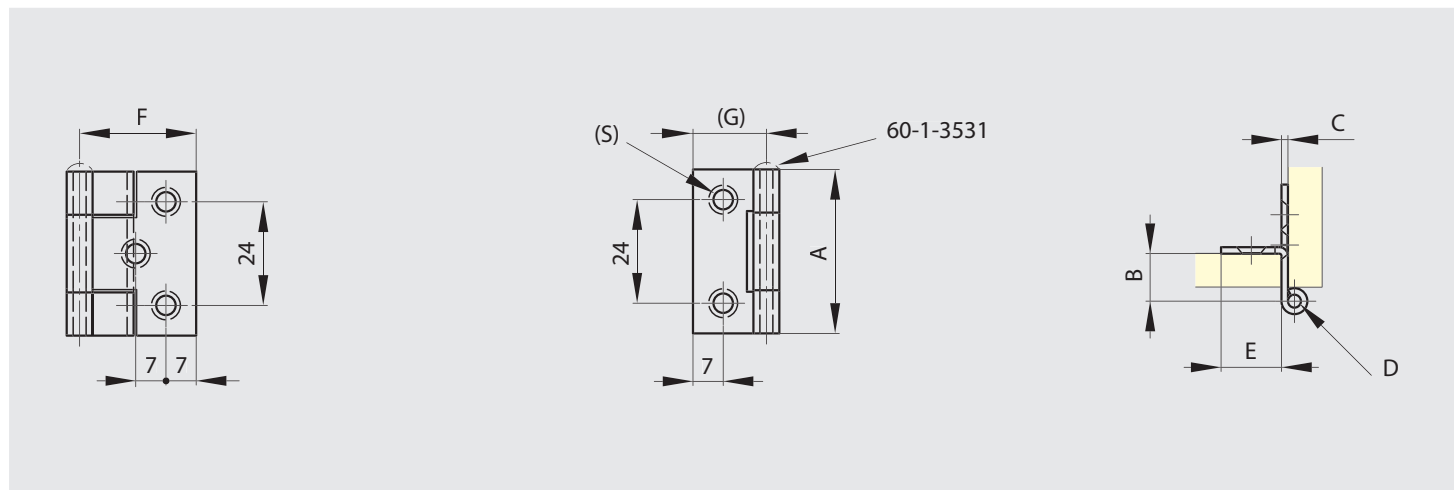



Small butt hinge with one cranked leaf 50 mm

304 stainless steel pin.
For door thickness max. 11 mm.



Part number	Material	Finish	A	B	C	D	E	S	Weight (g)
62-1-3300	430 stainless steel	polished	50	28.5	1	3	12	4	20

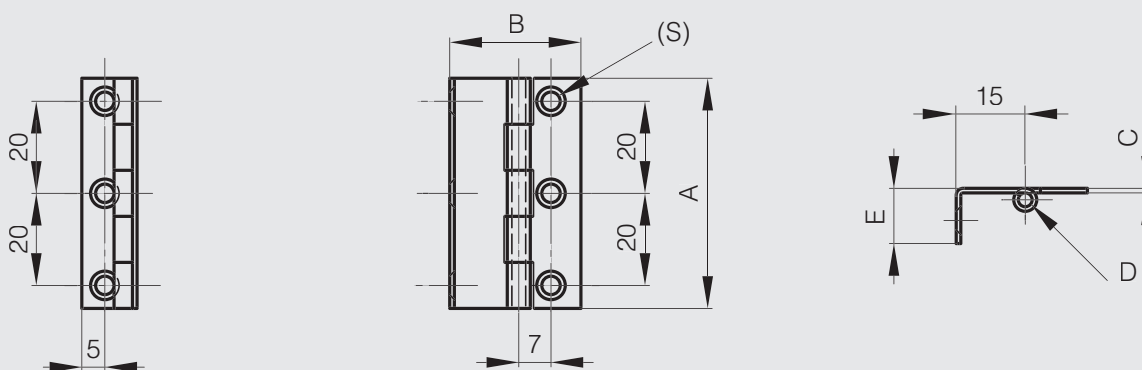

Small butt hinge with one cranked leaf and removable pin 50 mm

Removable pin.
Door thickness: max. 20 mm.



Part number	Material	Finish	A	B	C	D	E	S	Weight (g)
62-1-3301	430 stainless steel	polished	50	44.8	1.2	3	19	4.8	33

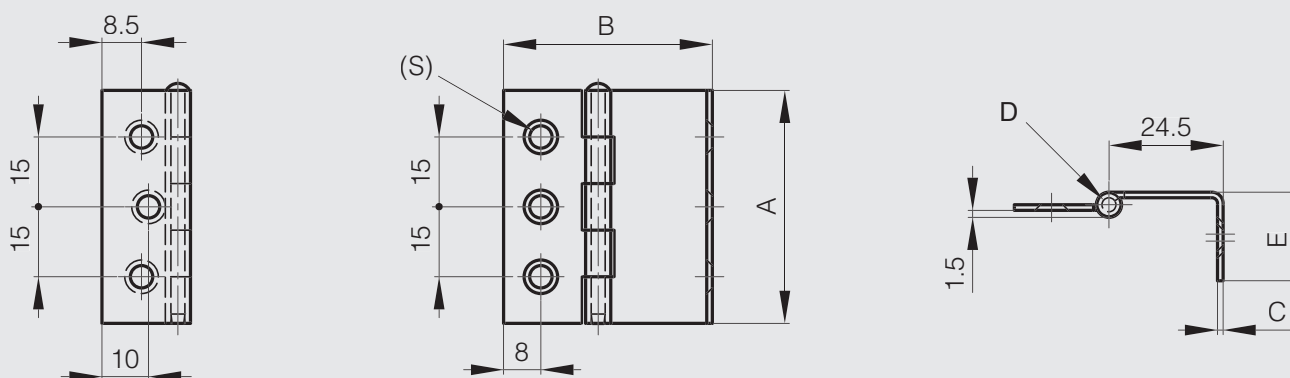



Stainless steel range - Hinges

Various hinges

Small butt hinge with one cranked leaf 60 mm

The same hinge is available with a spring (part number 71-1-3622).



Part number	Material	Finish	A	B	C	D	S1	S2	Weight (g)
62-1-3625	316L stainless steel	brightened	60	30	1.5	3	4.2	5	40

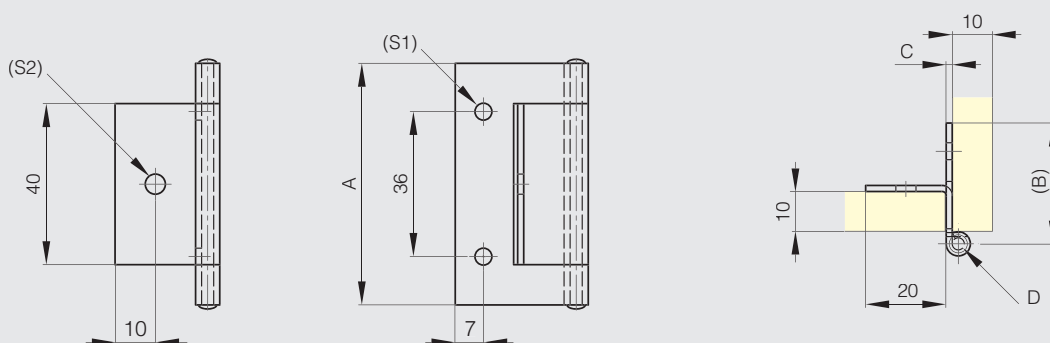

Small butt hinge with one cranked leaf 66 mm

The same hinge is available with a spring (part number 71-1-3649).

Pin in 316 stainless steel.



Part number	Material	Finish	A	B	C	D	S	Weight (g)
62-1-3637	316 stainless steel	brightened	66	22.5	1.5	4	4	310

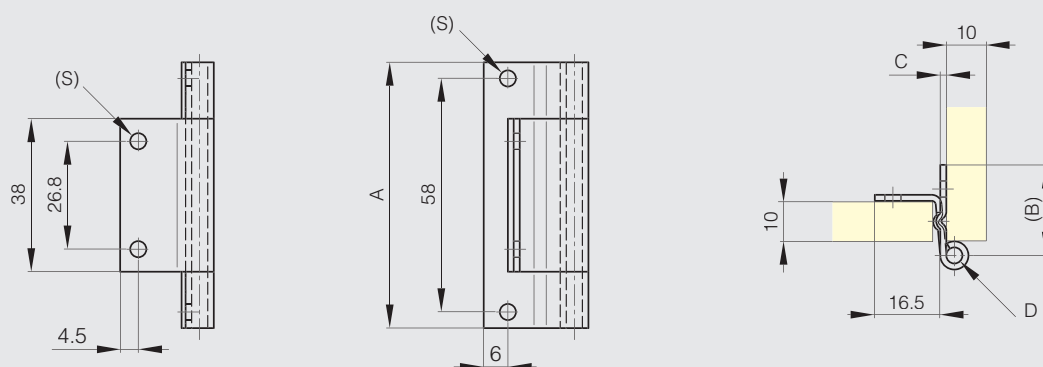



Pin hinge with one cranked leaf



Part number	Material	Finish	A	B	C	D	E	S	Note	Weight (g)
12-1-3682	304 stainless steel	raw	60	72	2	5	30	4	type 2	70
12-1-3683	304 stainless steel	raw	60	72	2	5	30	4	type 1	70

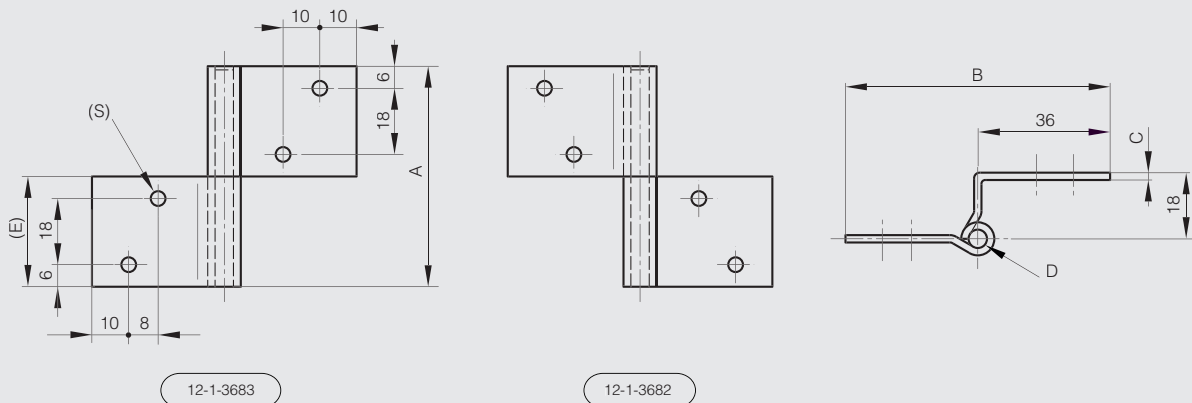

Stainless steel hinge with removable pin



Removable pin.

Part number	Material	Finish	A	B	C	D	Weight (g)
52-1-3877	304 stainless steel	brightened	60	94.5	1.5	4	50

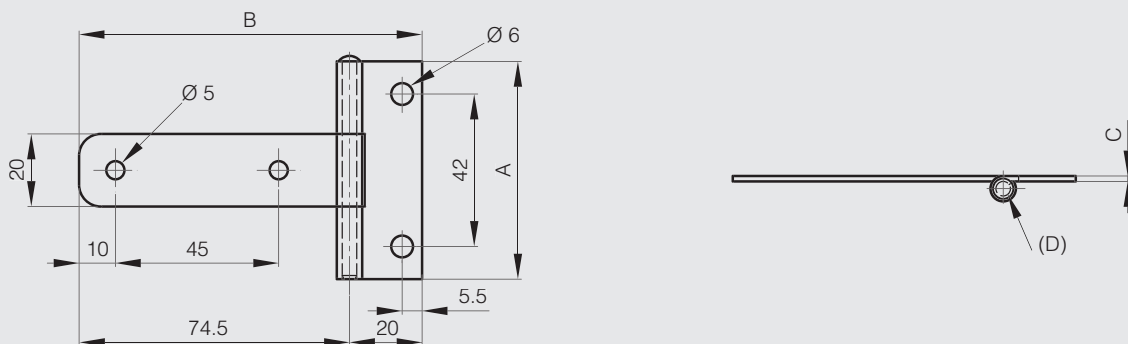



Various hinges

Removable pin hinges with nylon washers

Nylon washers.



Part number	Material	Finish	A	B	C	D	E	S	Note	Weight (g)
52-1-3605	304 stainless steel	raw	112	136.5	2.5	5	63.5		undrilled	248
52-1-3606	304 stainless steel	raw	112	136.5	2.5	5	63.5	7	drilled	248

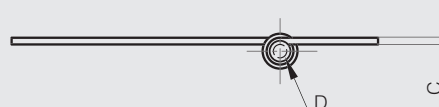
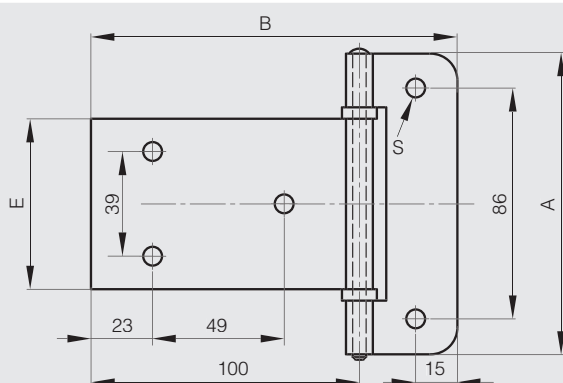

Hinges 62 x 74 mm



Part number	Material	Finish	A	B	C	D	Weight (g)
52-1-3769	304 stainless steel	raw	62	74	2	4.9	54

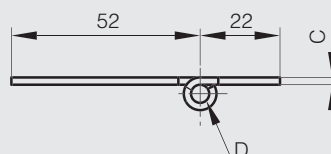
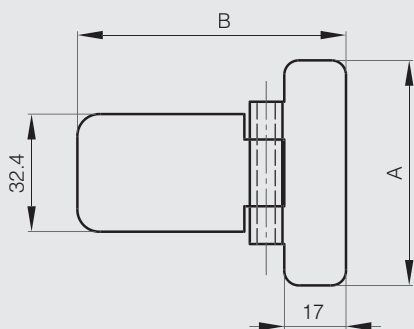



Hinge 20 x 65 mm



Part number	Material	Finish	A	B	C	D	S	Weight (g)
52-1-4013	304 stainless steel	raw	20	65	1	2	4	11

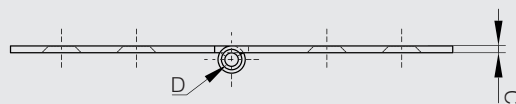
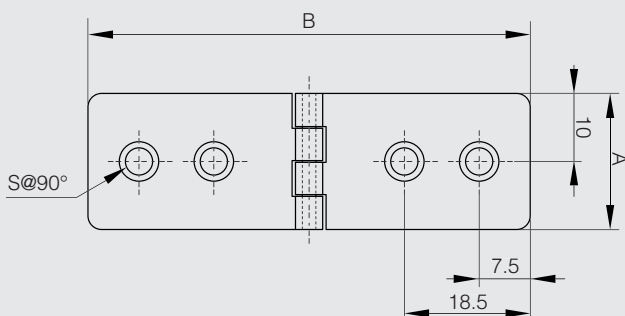

Flag hinge without washer with two offset leaves



Part number	Material	Finish	A	B	C	D	E	Weight (g)
12-1-3769	304 stainless steel	raw	60	40	1.5	5.3	30	38
12-1-3770	304 stainless steel	raw	80	48	2	6	40	74

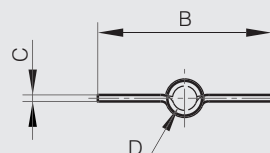
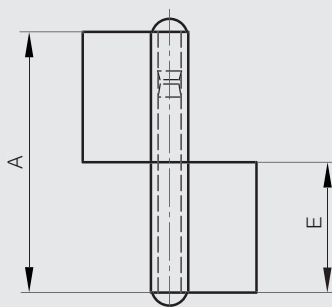



Flag hinge with washer with two offset leaves

Flag hinge with brass washer, included separately.



Part number	Material	Finish	A	B	C	D	E	Weight (g)
12-1-3771	304 stainless steel	raw	61.5	40	1.5	5.3	30	39
12-1-3772	304 stainless steel	raw	81.5	48	2	5.8	40	75

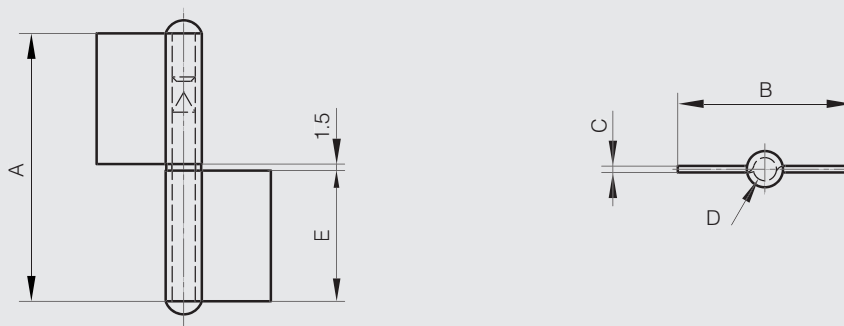

Flag hinge without washer - drilled - flat knuckle



Part number	Material	Finish	A	B	C	D	Note	Weight (g)
NEW 12-1-4258	304 stainless steel	raw	80	48	2	6	type 1	76
NEW 12-1-4285	304 stainless steel	raw	80	48	2	6	type 2	76

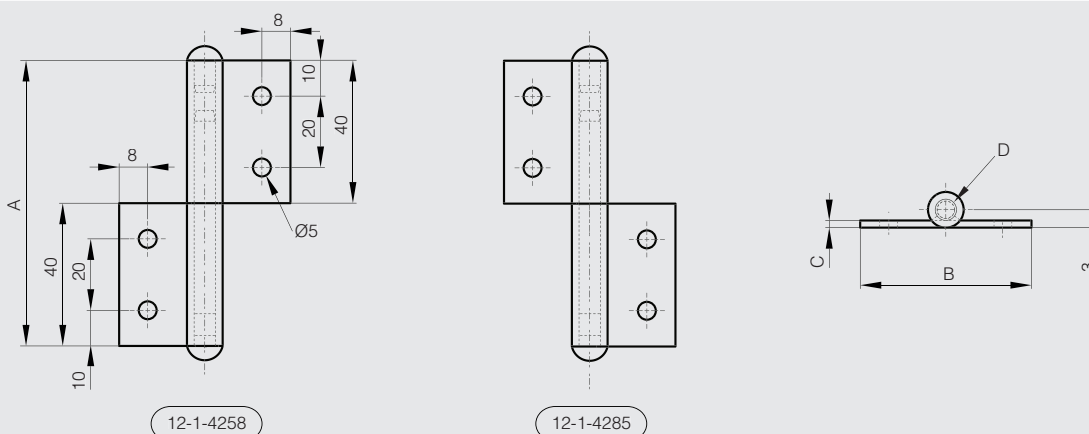



Glass door hinge in brushed stainless steel



Supplied with EPDM gasket.
Included stainless steel bolts and stainless steel washers.

	Part number	Material	Finish	A	B	C	D	Weight (g)
NEW	52-1-4040	304 stainless steel	brushed	40	35	2	4	80

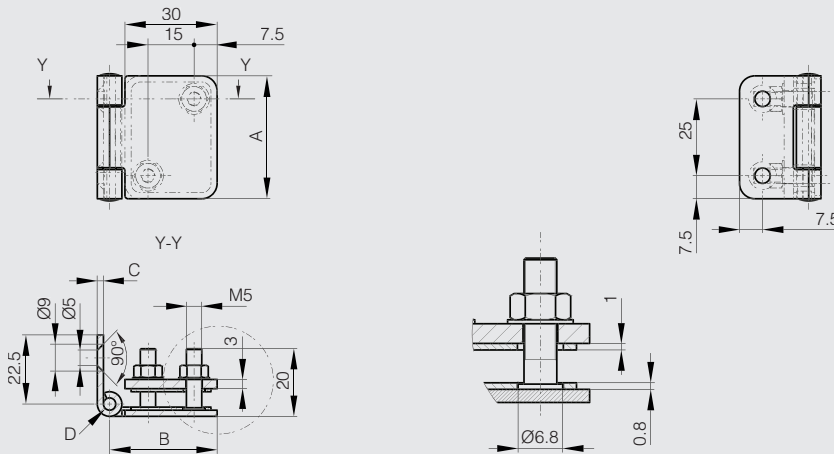

Glass door hinge in stainless steel



Hinge for glass / acrylic doors (PMMA).
Door thickness: 4 - 6 mm.
Door weight: max. 4 kg / pair.
Leaves, pin and screw in 304 stainless steel. Plate in aluminium alloy, washer in chloroethylene.

	Part number	Material	Finish	A	B	C	D	Weight (g)
	72-7-4254	304 stainless steel	raw	34	32	1.2	5	15

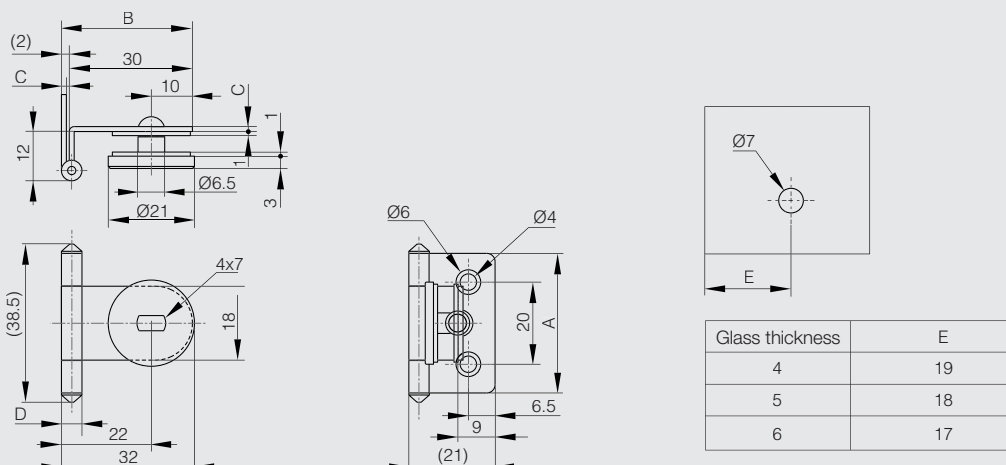



Slam latches

Slam latch in stainless steel - bolt "nose-up"



Stainless steel slam latch.

Part number	Material	Finish	A	B	C	D	E	F	G	H	K	S	Weight (g)
NEW 16-1-4265	304 stainless steel	raw	56	73.5	2.7	1.2	20	22	30	29.7	12	5.5	87

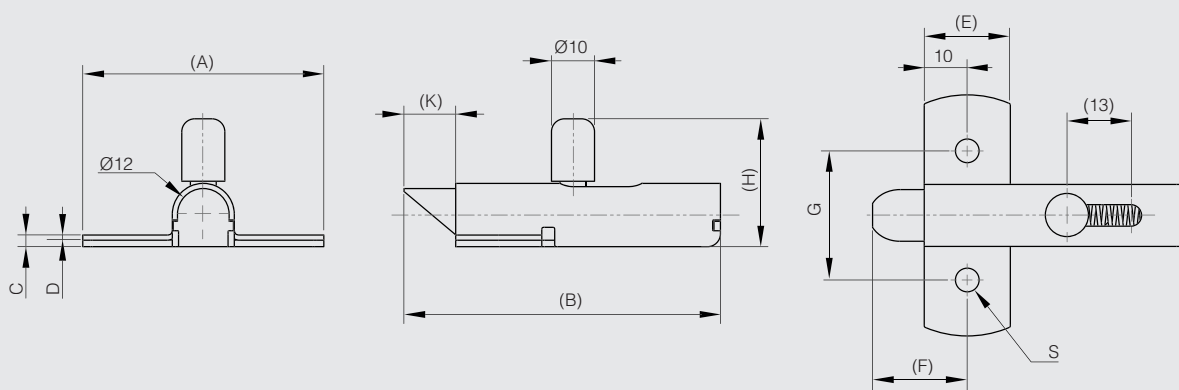

Slam latch in stainless steel - bolt "nose-down"



Stainless steel slam latch.

Part number	Material	Finish	A	B	C	D	E	F	G	H	K	S	Weight (g)
NEW 16-1-4282	304 stainless steel	raw	56	73.5	2.7	1.2	20	22	30	29.7	12	5.5	87

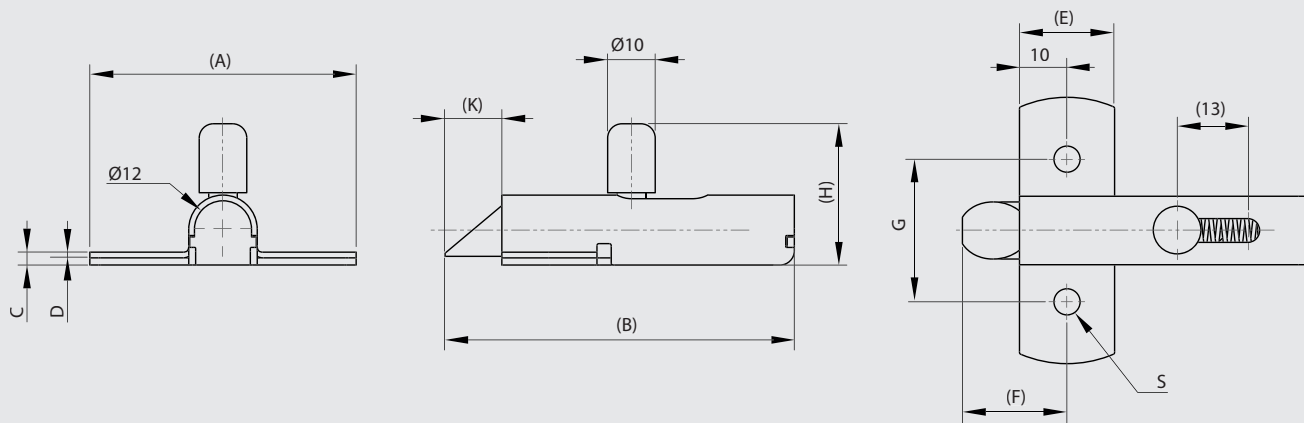



Slam latches

Springloaded bolt - reversible bolt

Slam blot - reversible.

Bolt can be manually unassembled to be positioned 'nose-up' or 'nose-down'.

Minimum load 50 N for full bolt travel.



Part number	Material	Finish	A	B	C	K	Note	Weight (g)
16-7-3835	304 stainless steel	raw	63.2	57	17.2	7	bolt delivered 'nose-down'	185

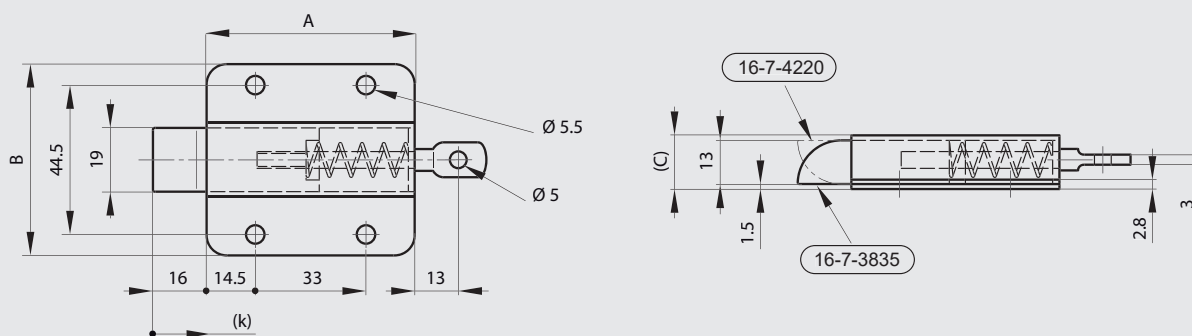

Paddle latches 68.5 x 84 mm

Available with or without key.

Keyed alike for version with cylinder.

Spring in stainless steel.



Part number	Material	Finish	A	B	Note	Weight (g)
16-1-4107	304 stainless steel	raw	68.5	84	without key	184
16-1-4108	304 stainless steel	raw	68.5	84	with key	184

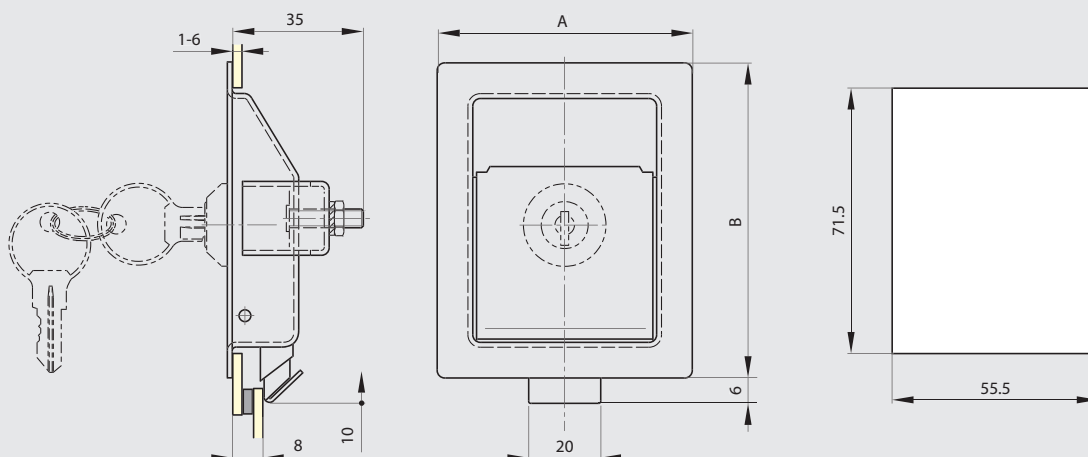



Concealed springloaded pin hinges A

Stainless steel spring. Circlip in 1.4122 stainless steel.



Part number	Material	Finish	A	B	C	D	K	Note	Weight (g)
12-1-3858	304 stainless steel	raw	82	18.2	2.8	6	12	type 2	46.4
12-1-3859	304 stainless steel	raw	82	18.2	2.8	6	12	type 1	46.4

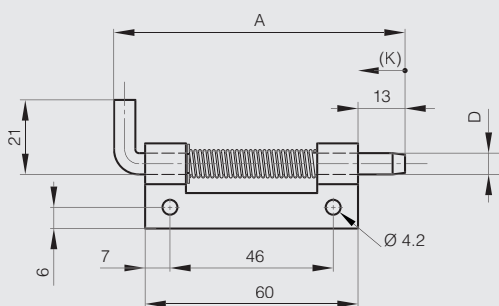

12-1-3857 & 12-1-3855 & 12-1-3859

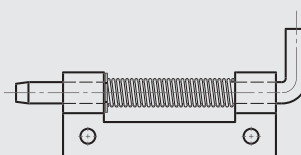

12-1-3856 & 12-1-3854 & 12-1-3858

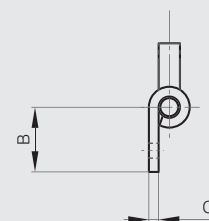

Concealed springloaded pin hinges B

Stainless steel spring. Circlip in 1.4122 stainless steel.



Part number	Material	Finish	A	B	C	D	K	Note	Weight (g)
12-1-3862	304 stainless steel	raw	82	21	14	5	12	type 2	38.5
12-1-3863	304 stainless steel	raw	82	21	14	5	12	type 1	38.5

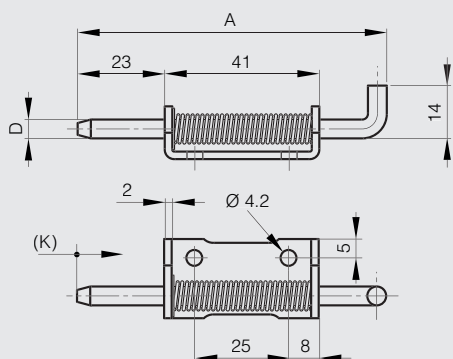

12-1-3951 & 12-1-3861 & 12-1-3863

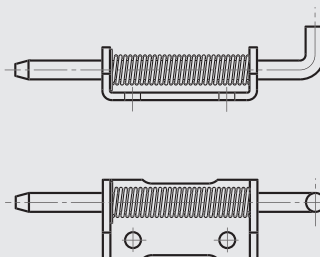

12-1-3950 & 12-1-3860 & 12-1-3862

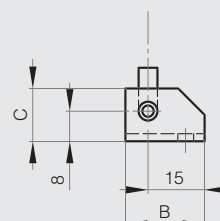



Stainless steel range - Latching systems

Spring-loaded latches

Springloaded bolt with locking system B



Heavy duty range. Stop when open.



	Part number	Material	Finish	A	B	K	Weight (g)
NEW	16-1-9025	304 stainless steel	raw	132	50	17	170

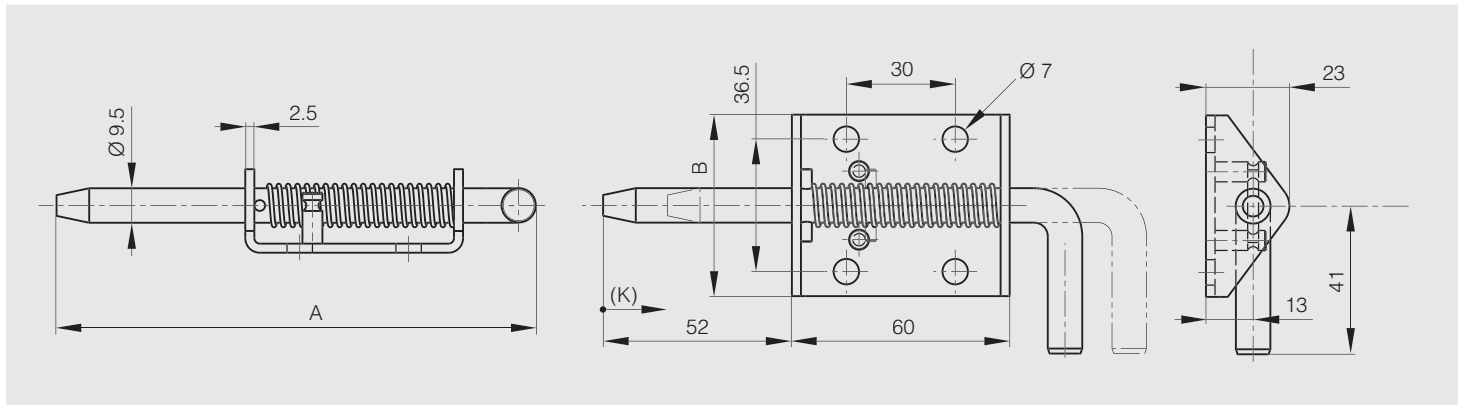

Push barrel bolt

Stainless steel latch with steel shaft and plastic button.



	Part number	Material	Finish	A	B	C	Weight (g)
	16-1-9008	stainless steel	raw	64	33.5	15	44

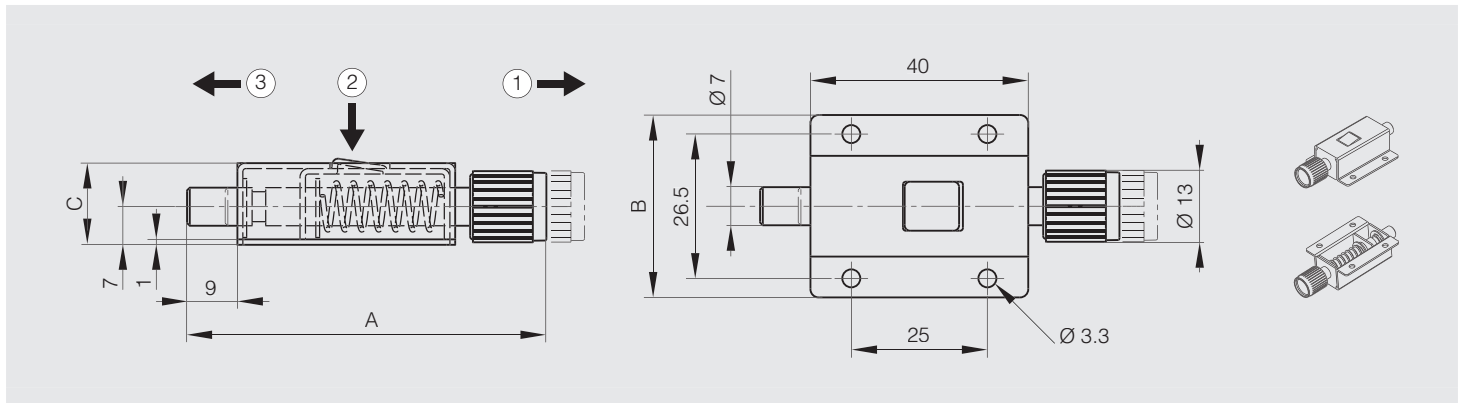



Budget latch - square 6x6 - stainless steel

Not handed.



Part number	Material	Finish	A	B	C	W	Weight (g)
16-1-3972	304 stainless steel	raw	85	17	8.5	90°	56

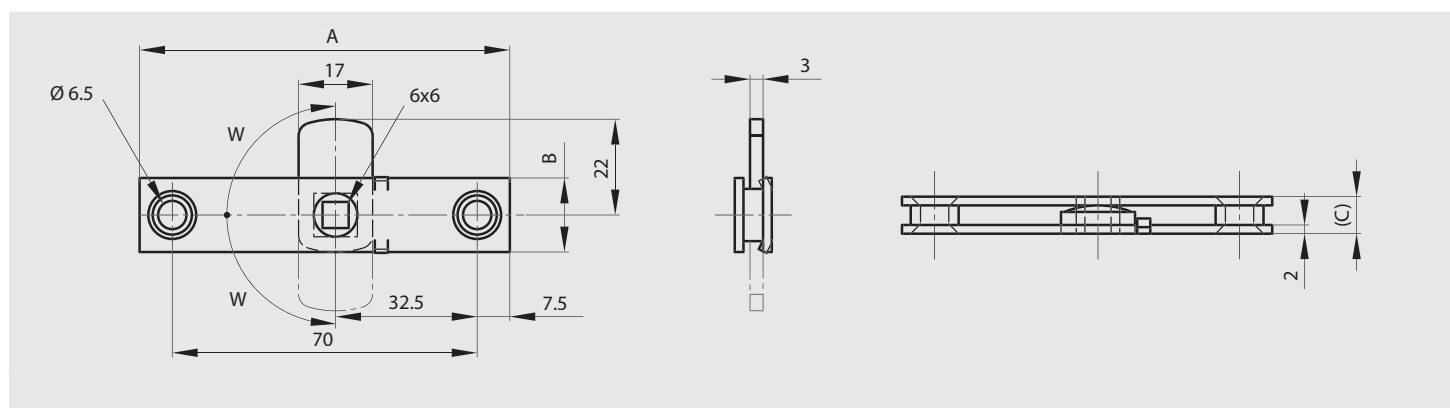

Budget latches - square 8x8

Not handed. 3 indent positions.



Part number	Material	Finish	A	B	C	W	Weight (g)
16-1-4086	304 stainless steel	raw	80	19	8	90°	63

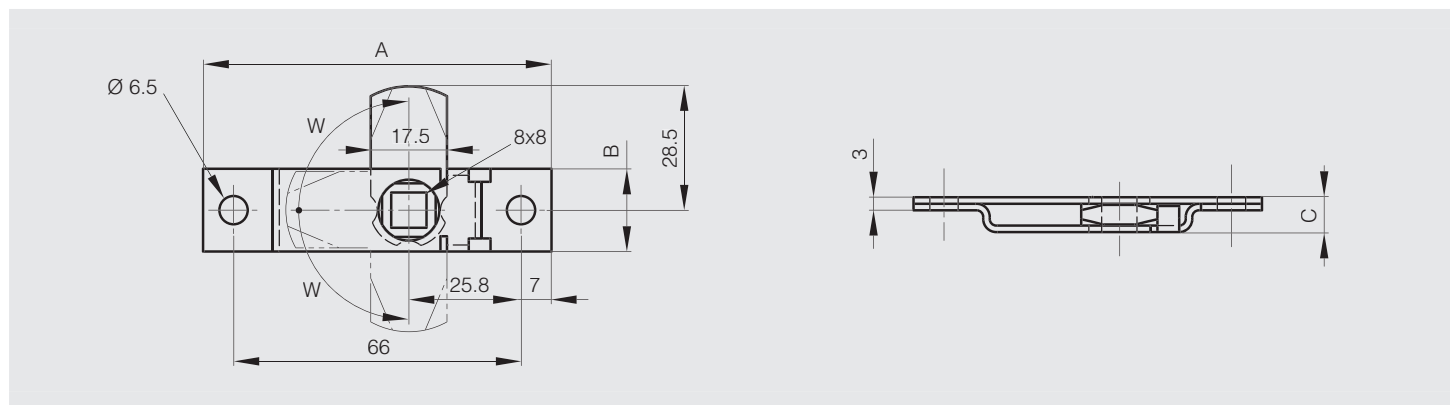



Rotary locks

Spring budget latch

Not handed.



Part number	Material	Finish	A	B	C	Note	Weight (g)
16-1-4031	304 stainless steel	deburred	85	53.4	8.5	Budget latch (no strike)	69



Strike for spring budget latch 16-1-4031



Part number	Material	Finish	A	B	C	Note	Weight (g)
16-1-4032	304 stainless steel	deburred	85	17	8.5	strike	48

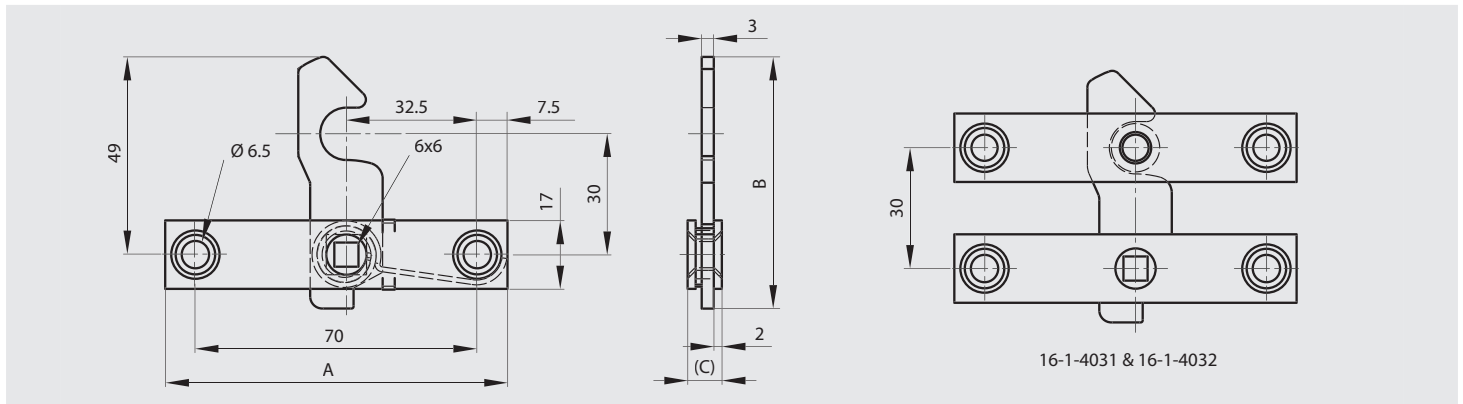



Barrel bolts

Barrel bolt in stainless steel

Can be fixed in vertical or horizontal position (stop when locked).
Supplied with 2 different strikes (see drawing).

STAINLESS
STEEL

Part number	Material	Finish	A	B	C	Weight (g)
16-7-3863	304 stainless steel	satin	50	37	27	80

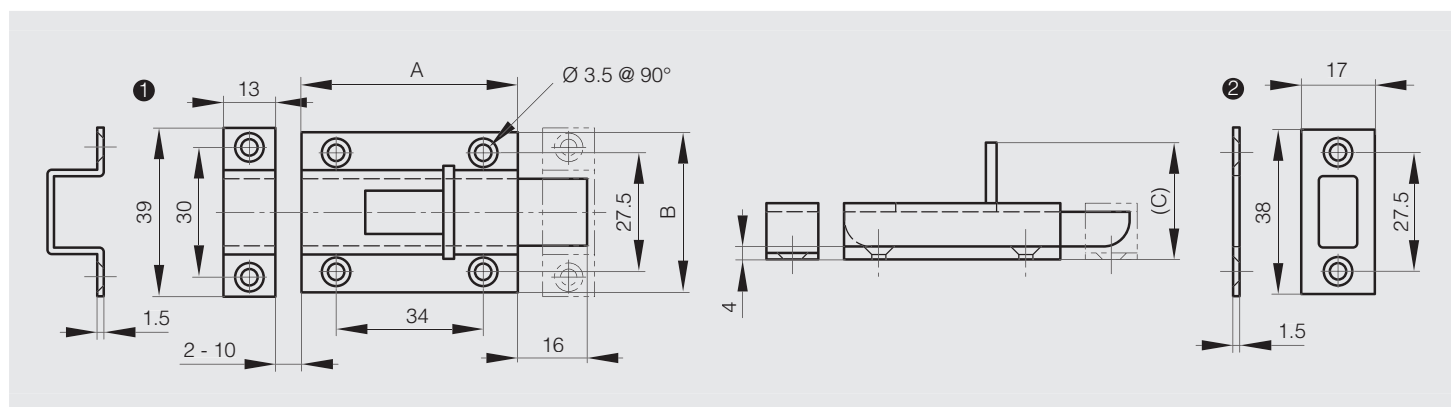



Stainless steel dual ball catches



Can be installed vertically or horizontally.
Catch force is not adjustable. Do not turn the slot part.



Part number	Material	Finish	A	B	C	C1	C2	D	E	F	G	H	J	K	L	S	Force	Weight (g)
NEW 16-7-4305	316 stainless steel	polished	43	8	13.5	10	6	28.4	2.5	35	16	25	7.5	11	2.5	3.2	1.3	18
NEW 16-7-4306	316 stainless steel	polished	50	10	16.1	12.2	7.7	31.5	2.9	40	20	30	9	13.2	2.9	4.2	1.8	30
NEW 16-7-4307	316 stainless steel	polished	70	13	23	17	10.5	51	4	60	30	42	10.5	19	4	4.2	3.9	83

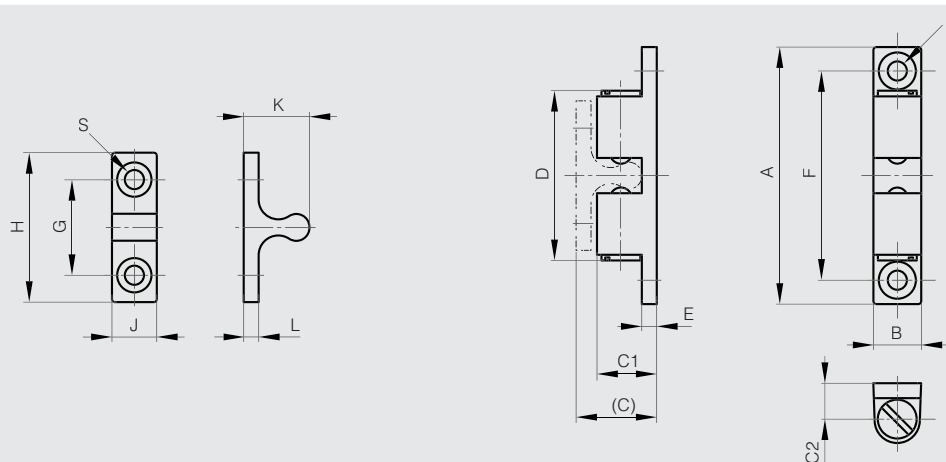



Magnetic catches

Compact magnetic catch



Suitable for temperatures below 80°C.

To avoid breakage, counterplate should not connect with magnet.

Screw heads should not protrude above the base plate.

For the stainless steel version, magnet is coated with acrylic resin to be corrosion resistant.

	Part number	Material	Finish	A	B	C	Force	Weight (g)
NEW	16-7-4309	430 stainless steel	polished	41	16.5	2.8	5kg	13

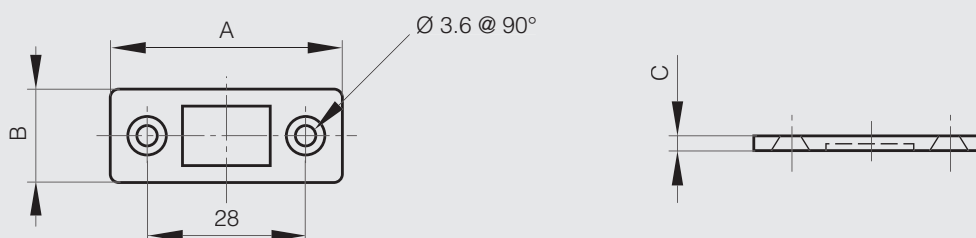

Screw-on magnetic catch without counter plate - force 14 kg



Strong magnetic force.

Material: 304 stainless steel / steel / neodymium.

Counter plate not included.

	Part number	Material	Finish	A	B	C	D	Force	Weight (g)
NEW	16-7-4297	304 stainless steel	polished	50	17	12.3	40	14kg	41

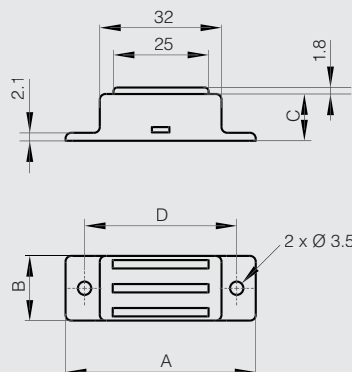



Magnetic catches

Screw-on magnetic catch without counter plate - force 7 and 14 kg - high temperature resistance

Suitable for high temperature environments up to 250°C.

Strong magnetic force. Corrosion free.

Counter plate not included.



	Part number	Material	Finish	A	B	C	D	Force	Weight (g)
NEW	16-7-4294	304 stainless steel	polished	50	17	12.3	40	7.1Kg	40
NEW	16-7-4295	304 stainless steel	polished	50	17	12.3	40	14.3Kg	40

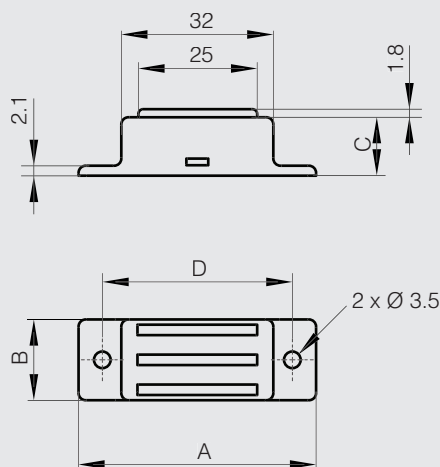



Toggles latches

Rotary toggle latches

Strike included.



Part number	Material	Finish	A	B	C	Note	Weight (g)
16-1-9013	304 stainless steel	raw	62	38	13.2	with strike	50

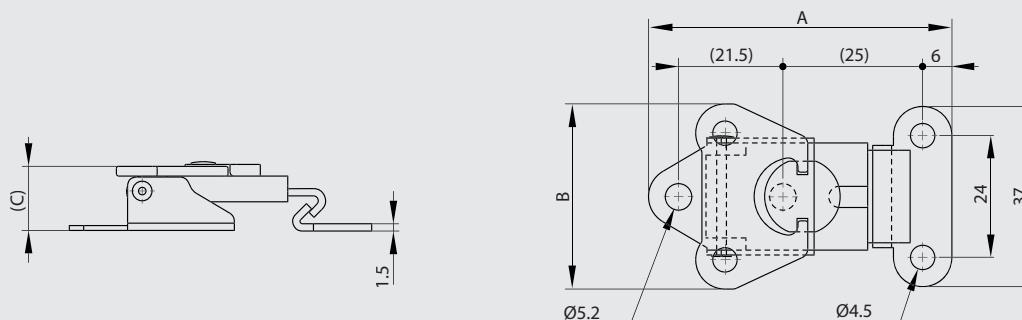

Spring loaded rotary toggle latches

Strike included.



Part number	Material	Finish	A	B	C	Note	Weight (g)
16-1-9015	304 stainless steel	raw	62	46	12	with strike	60

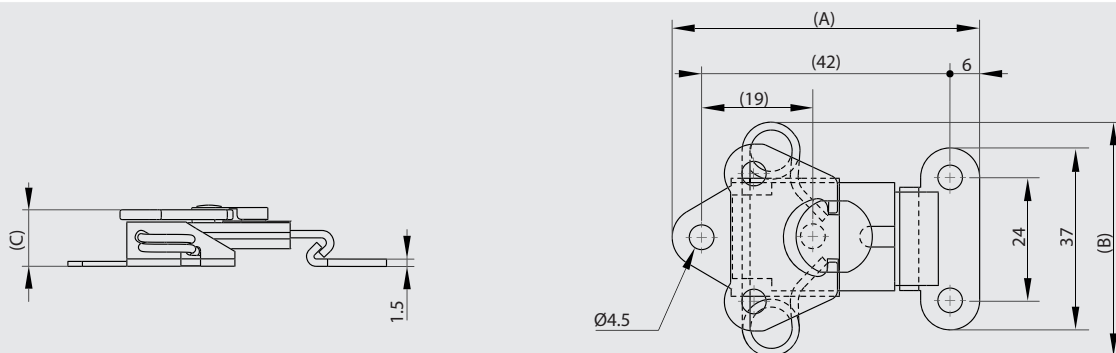



Toggles latches

Padlockable rotary toggle latches

Strike included.



Part number	Material	Finish	A	B	C	Note	Weight (g)
16-1-9017	304 stainless steel	raw	64	38	24	with strike	60

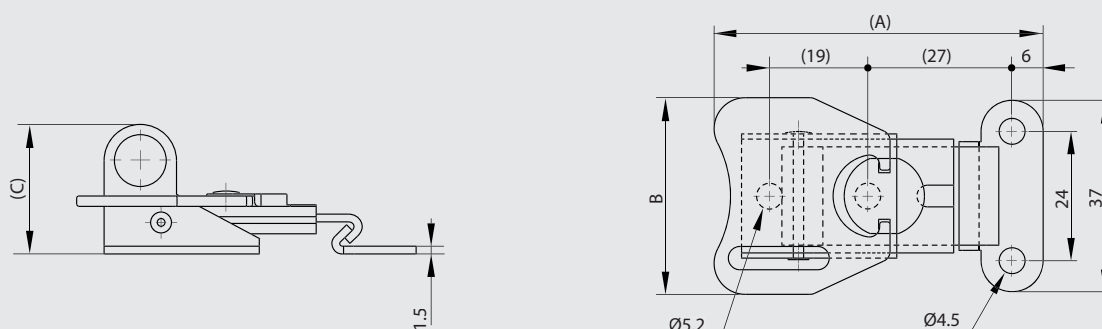

Lockable toggle latch without strike

Keyed alike (2 identical keys).

Strike not included.



Part number	Material	Finish	A	B	C	Weight (g)
16-1-4257	304 stainless steel	raw	106.5	40	17	132

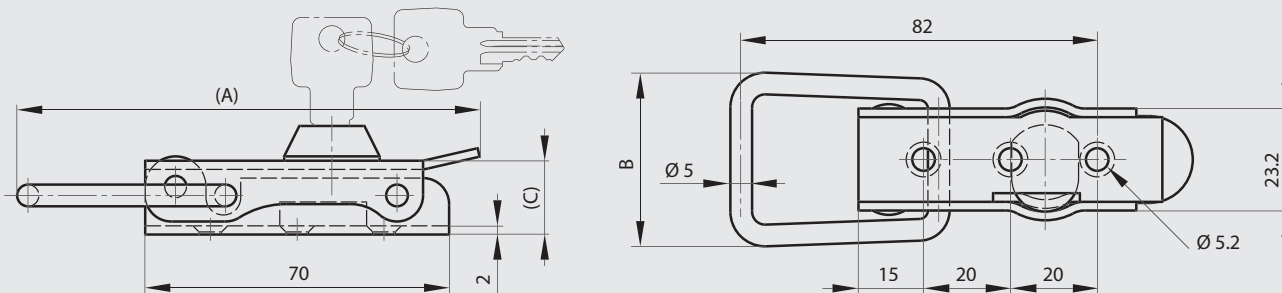



Toggles latches

Strike for part number 16-1-4257



Part number	Material	Finish	A	B	Weight (g)
16-7-3601	304 stainless steel	raw	28	25	24

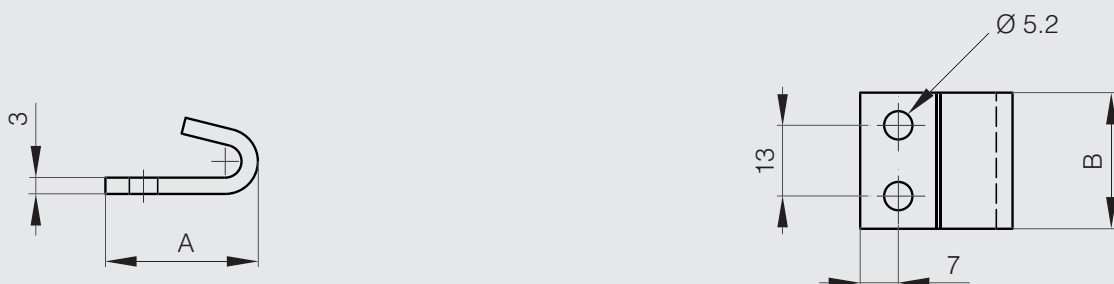

Toggle latches without strike - 50 mm

These latches are used with strike part numbers 16-7-3414, 16-7-3529 and 16-7-3531.
 Padlockable option available for part number 16-7-3394.



Part number	Material	Finish	A	B	C	Note	Weight (g)
16-7-3525	304 stainless steel	raw	50	22	12.5	drilled	20
16-7-3527	304 stainless steel	raw	50	23.4	11.7	undrilled	20

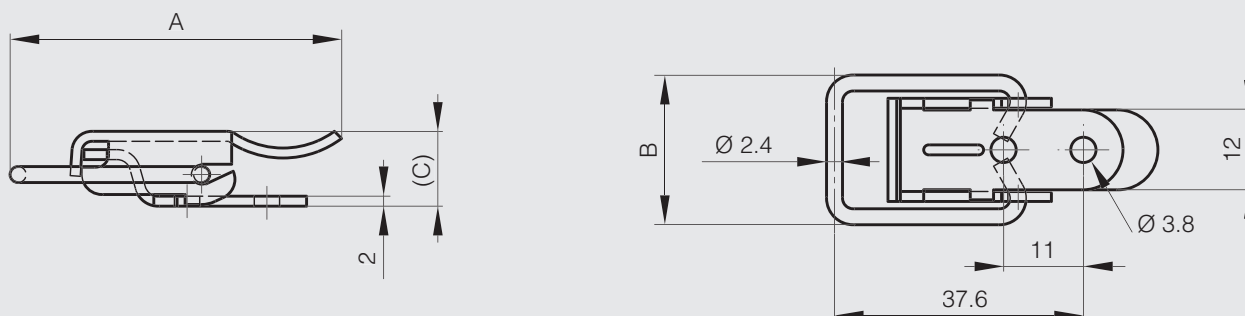



Toggles latches

Strikes for part numbers 16-7-3525 and 16-7-3527



Part number	Material	Finish	A	B	C	D	E	Note	Weight (g)
16-7-3531	304 stainless steel	raw	13.4	24	1.5			undrilled	3.5
16-7-3529	304 stainless steel	raw	13.4	24	1.5	14	5	drilled	3.5

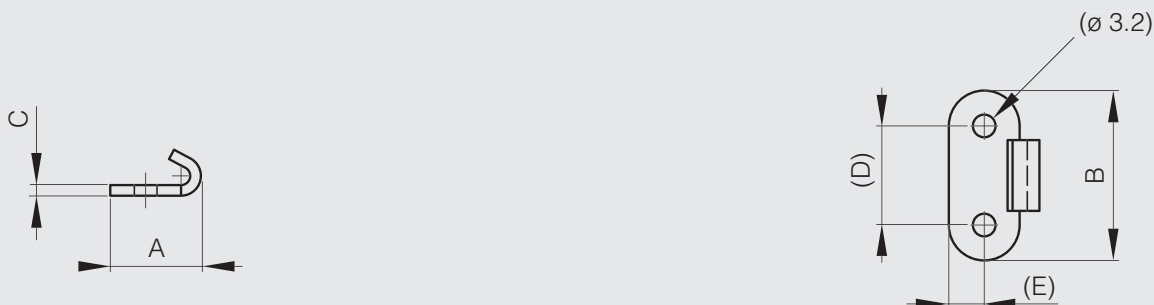

Toggle latches with strike - 52 mm



Part number	Material	Finish	A	B	C	Weight (g)
16-7-3846	304 stainless steel	raw	52	41	13.5	23

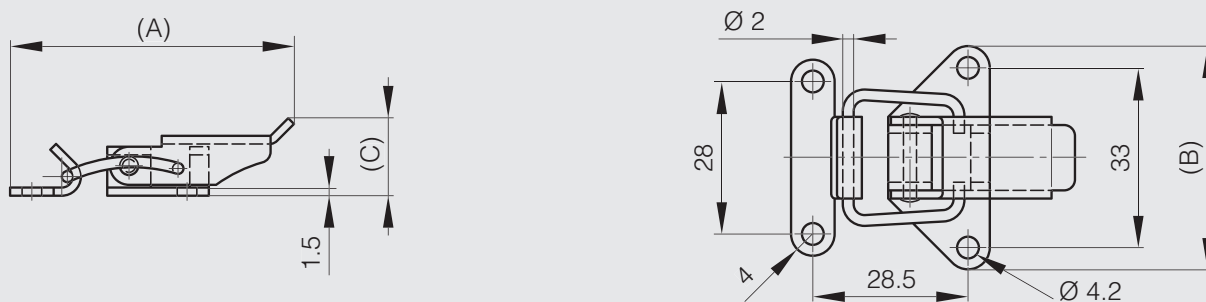



Toggles latches

Toggle latch without strike - 58.1 mm

This latch is used with strike, part numbers 16-7-3873 and 16-7-3874.



Part number	Material	Finish	A	B	C	Weight (g)
16-7-3876	304 stainless steel	raw	58.1	23.4	12.7	32

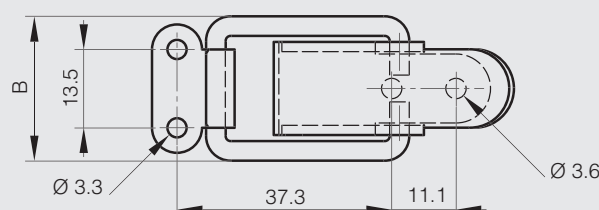
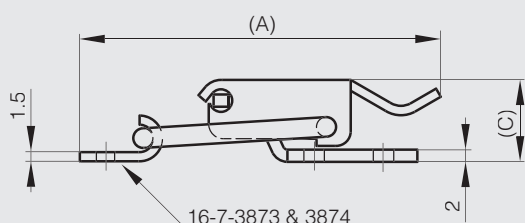

Strike for part number 16-7-3876



Part number	Material	Finish	Weight (g)
16-7-3874	304 stainless steel	raw	3.5





Toggles latches

Toggle latch without strike - 80.2 mm

This latch is used with strike reference 16-7-3530.

This latch is available with padlockable option reference 16-7-3724.



Part number	Material	Finish	A	B	C	Note	Weight (g)
16-7-3526	304 stainless steel	raw	80.2	32	14.5	drilled	53.5

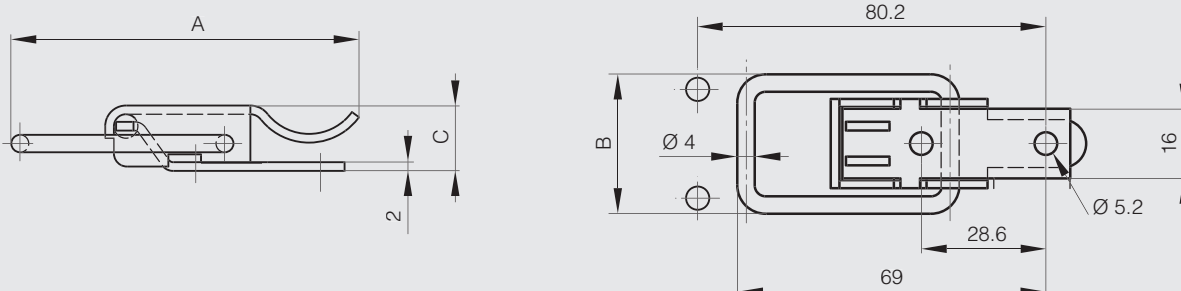

Strike for part number 16-7-3526



Part number	Material	Finish	A	B	C	D	E	Note	Weight (g)
16-7-3530	304 stainless steel	raw	20	26.5	2	15	5.2	drilled	9

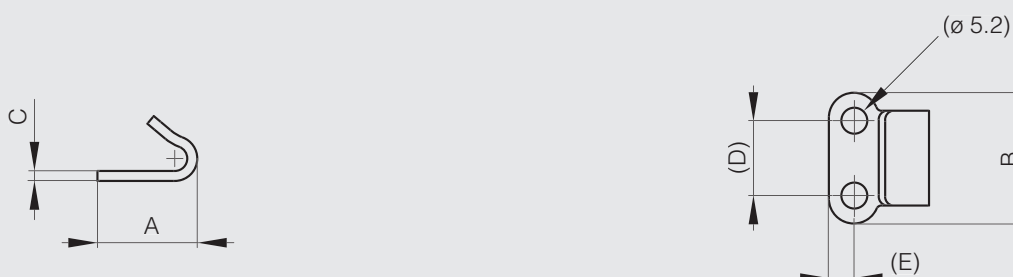



Toggles latches

Toggle latches without strike - 88.5 mm

Punched holes.

This latch is used with strike part number 16-7-3601.



Part number	Material	Finish	A	B	C	Weight (g)
16-7-3829	304 stainless steel	raw	88.5	40	20	106

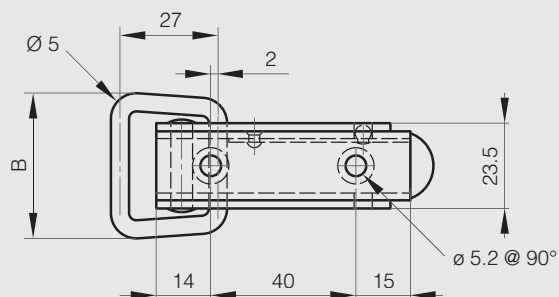
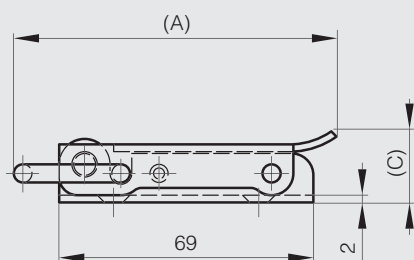

Strike for part number 16-7-3829



Part number	Material	Finish	A	B	Weight (g)
16-7-3601	304 stainless steel	raw	28	25	24

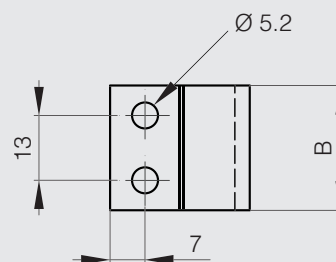
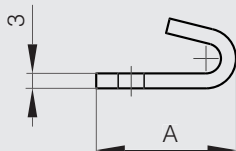



Other strike for part number 16-7-3829

Drilled and countersunk for 4,5 mm diameter screws.



Part number	Material	Finish	A	B	Weight (g)
16-7-3828	304 stainless steel	raw	85	25	57

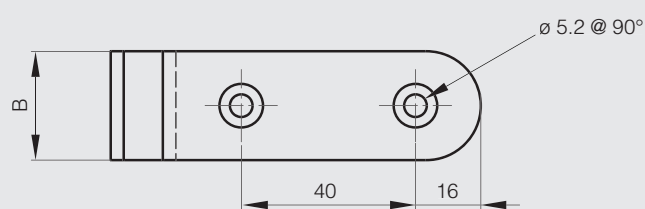
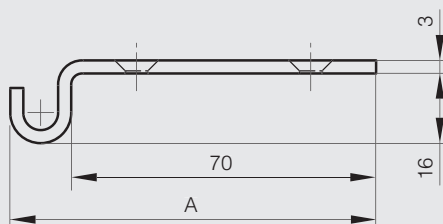



Toggle latches

Toggle latch without strike (consistent tension)

This latch is used with strike part number 16-7-3874.



Part number	Material	Finish	A	B	C	Weight (g)
16-7-3891	304 stainless steel	raw	58.6	20.6	12.7	27

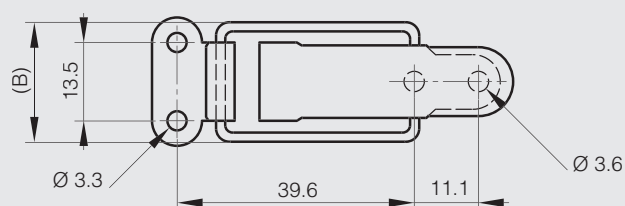
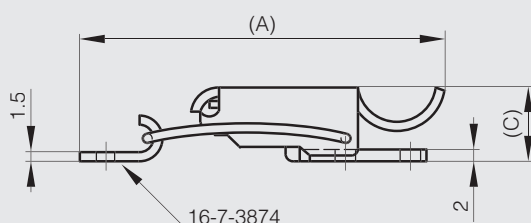

Strike for part number 16-7-3891



Part number	Material	Finish	Weight (g)
16-7-3874	304 stainless steel	raw	3.5





Toggles latches

Padlockable toggle latch - 80.2 mm

This latch is used with strike part number 16-7-3730.



Part number	Material	Finish	A	B	C	Note	Weight (g)
16-7-3724	304 stainless steel	raw	80.2	32	23.5	drilled	55

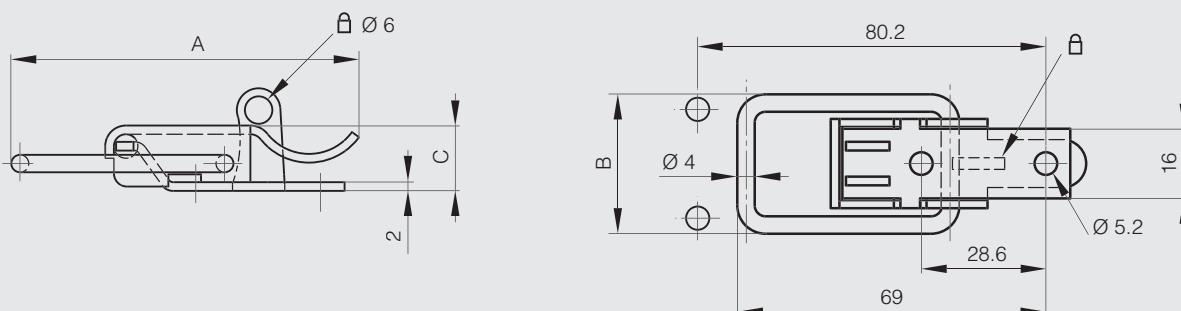

Strike for part number 16-7-3724



Part number	Material	Finish	A	B	Note	Weight (g)
16-7-3730	304 stainless steel	raw	27.4	26	drilled	10

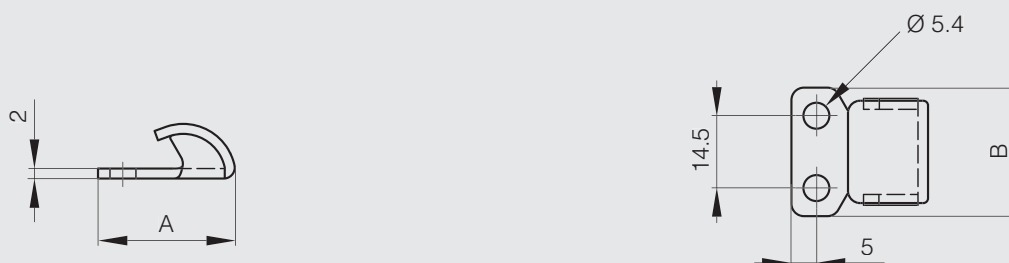



Toggles latches

Padlockable toggle latch - 97.6 mm

This latch is used with strike part number 16-7-3885.



Part number	Material	Finish	A	B	C	Weight (g)
16-7-3884	304 stainless steel	raw	97.5	33	23.1	68

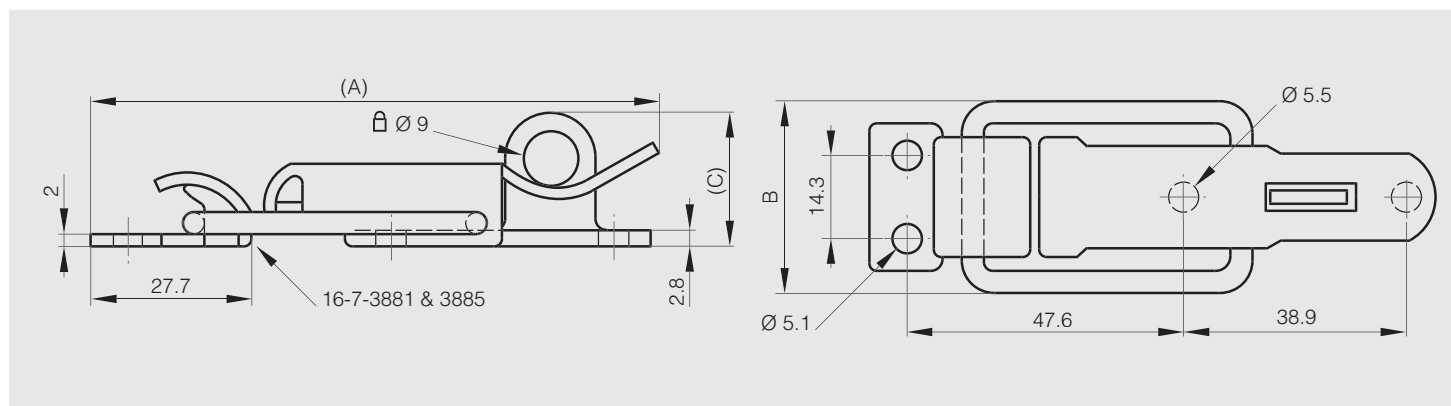

Strike for part number 16-7-3884



Part number	Material	Finish	Weight (g)
16-7-3885	304 stainless steel	raw	9





Toggles latches

Spring loaded and padlockable toggle latch - 52 mm

Dimension A (52 mm) without tension. Dimension A can be extended up to 3 mm putting the latch under tension. This latch is used with strike part numbers 16-7-3739 and 16-7-3742.



Part number	Material	Finish	A	B	C	Weight (g)
16-7-3760	304 stainless steel	raw	55.5	34.5	12	32

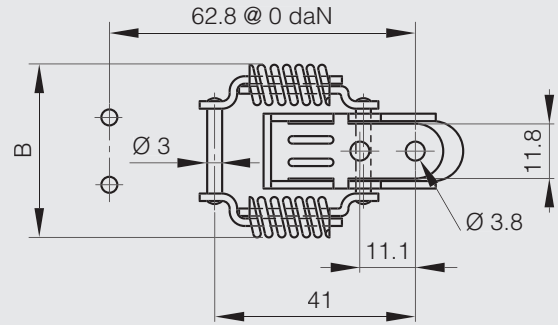
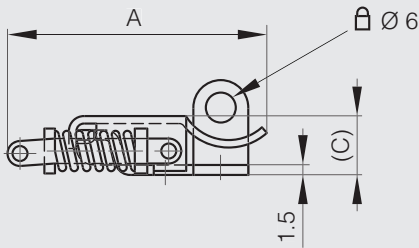

Strikes for part number 16-7-3760



Part number	Material	Finish	A	B	Note	Weight (g)
16-7-3739	304 stainless steel	raw	28.5	20.5	undrilled	3.5
16-7-3742	304 stainless steel	raw	28.5	20.5	drilled	3.5

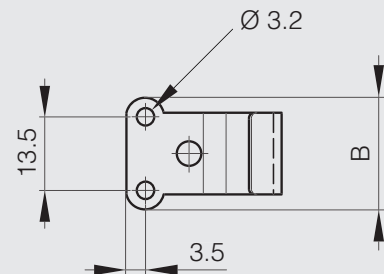
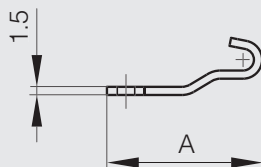



Toggles latches

Spring loaded and padlockable toggle latch - 74 mm

Dimension A (74 mm) without tension. Dimension A can be extended up to 4 mm putting the latch under tension. This latch is used with strike part numbers 16-7-3751 and 16-7-3754.



Part number	Material	Finish	A	B	C	Note	Weight (g)
16-7-3766	304 stainless steel	raw	74	46.5	15	drilled	75

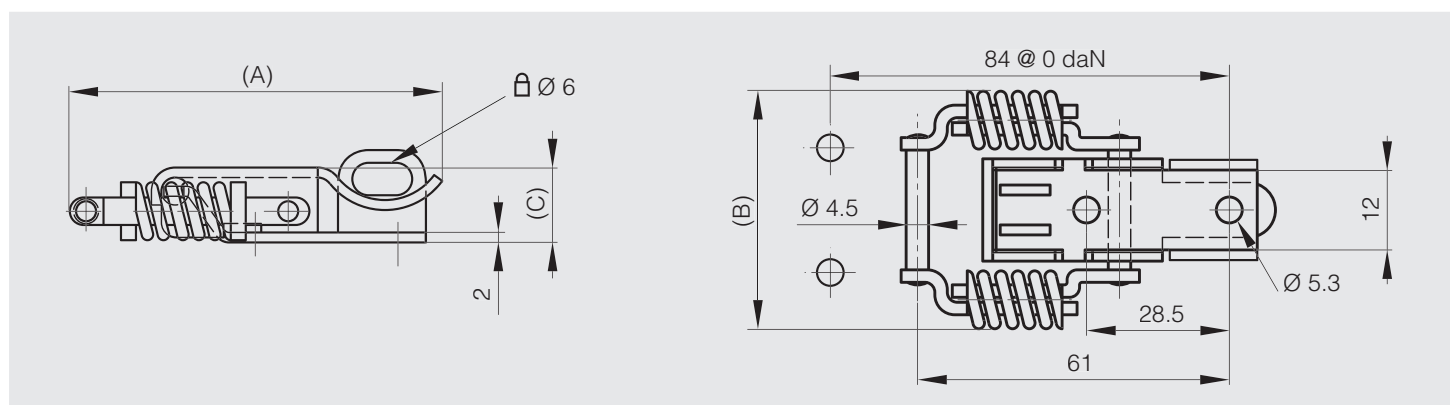

Strikes for part number 16-7-3766



Part number	Material	Finish	A	B	Note	Weight (g)
16-7-3751	304 stainless steel	raw	36	40	undrilled	20
16-7-3754	304 stainless steel	raw	36	40	drilled	20

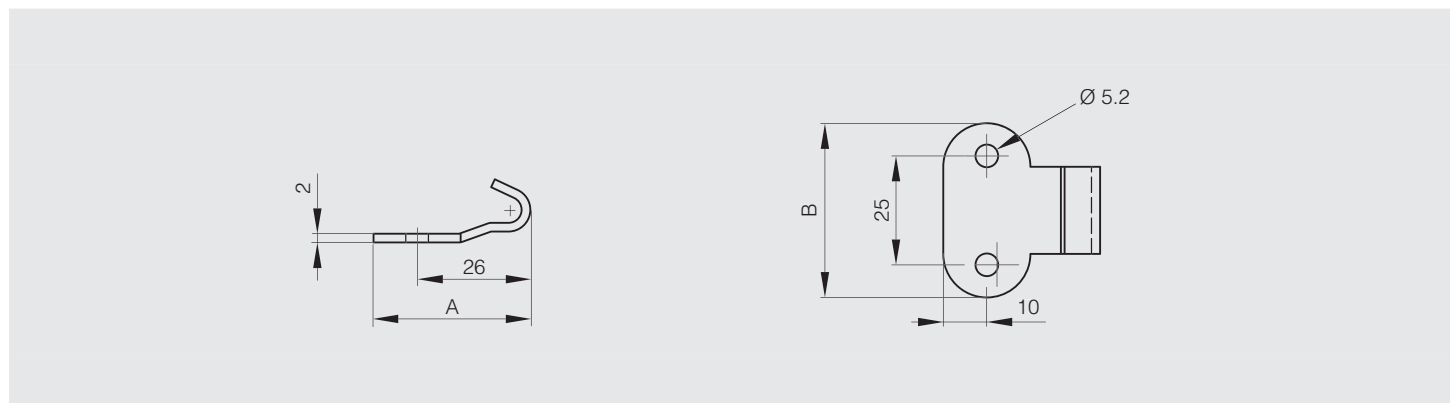



Toggles latches

Spring loaded and padlockable toggle latch - 70.9 mm

This latch is used with strike part number 16-7-3916.



Part number	Material	Finish	A	B	C	Weight (g)
16-7-3917	304 stainless steel	raw	70.9	28.7	23.1	50

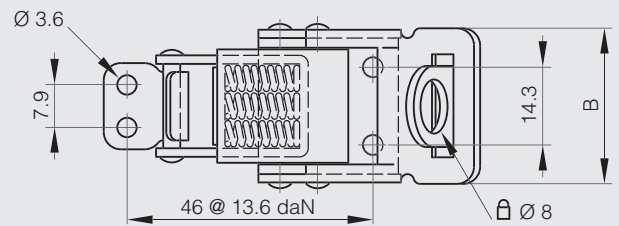
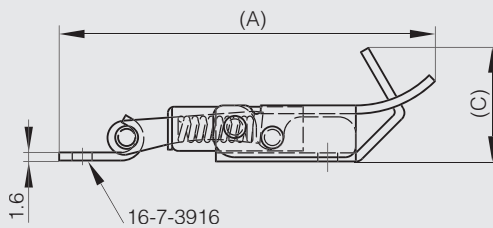

Strike for part number 16-7-3917



Part number	Material	Finish	Weight (g)
16-7-3916	304 stainless steel	raw	4.5





Toggles latches

Adjustable toggle latch - padlockable - 70.6 mm

This latch is used with strike part number 16-7-3940.



Part number	Material	Finish	A	B	C	Weight (g)
16-7-3938	304 stainless steel	raw	70.6	28.2	16	50

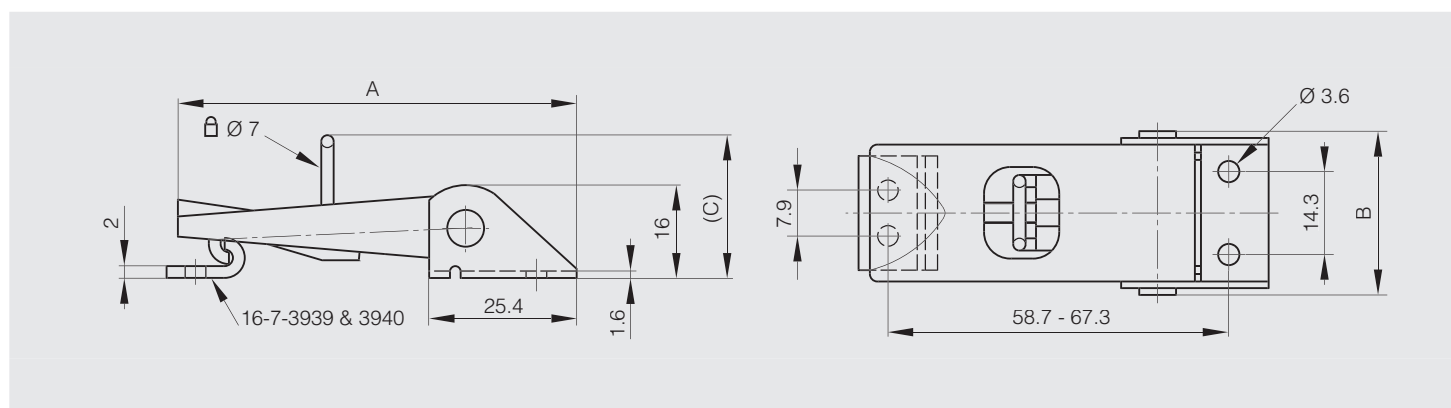

Strike for part number 16-7-3938

Strike for part number 16-7-3938.



Part number	Material	Finish	Weight (g)
16-7-3940	304 stainless steel	raw	4.5





Toggles latches

Adjustable toggle latches with strike - padlockable - 82 mm to 118 mm



Part number	Material	Finish	A	B	C	C1	C2	D	E	F	G	H	J	K	L	S	Note	Weight (g)
16-7-4025	304 stainless steel	raw	82	27	19	2	2	4	14	4.5	10	62-72	22	11	14	4	82<A<92	48
16-7-4027	304 stainless steel	raw	108	34	17	2.5	3	5	17	6.5	10	85-96	27	16	18	5.2	108<A<119	102
16-7-4028	304 stainless steel	raw	118	39	22	3	2.5	6	20	6.5	18	85-96	33	15	20	5.2	118<A<129	124

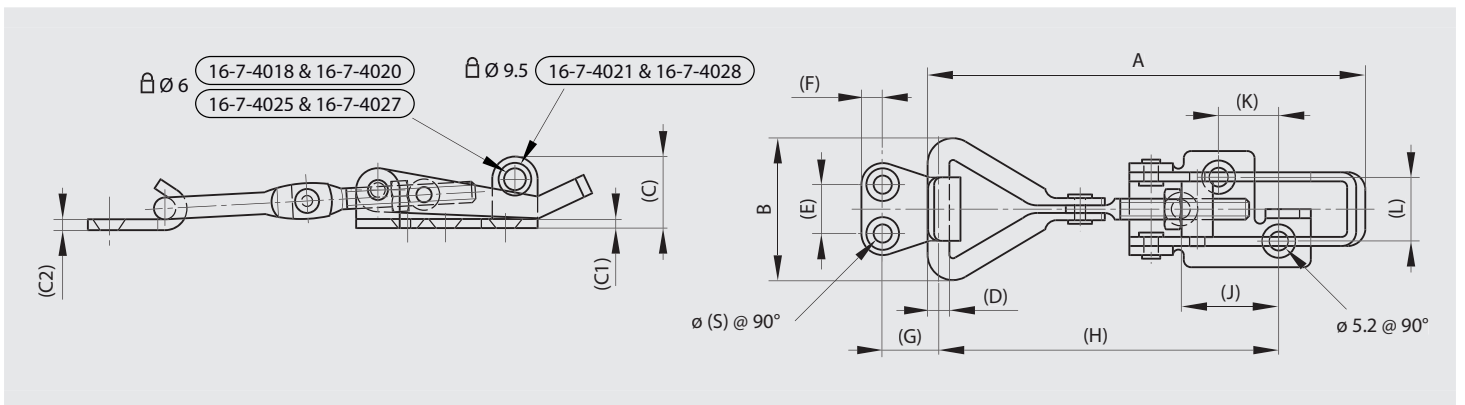

Adjustable toggle latch with strike - padlockable - 174 mm



Part number	Material	Finish	A	B	C	Note	Weight (g)
16-7-4030	304 stainless steel	raw	174	50	27	174<A<186	236

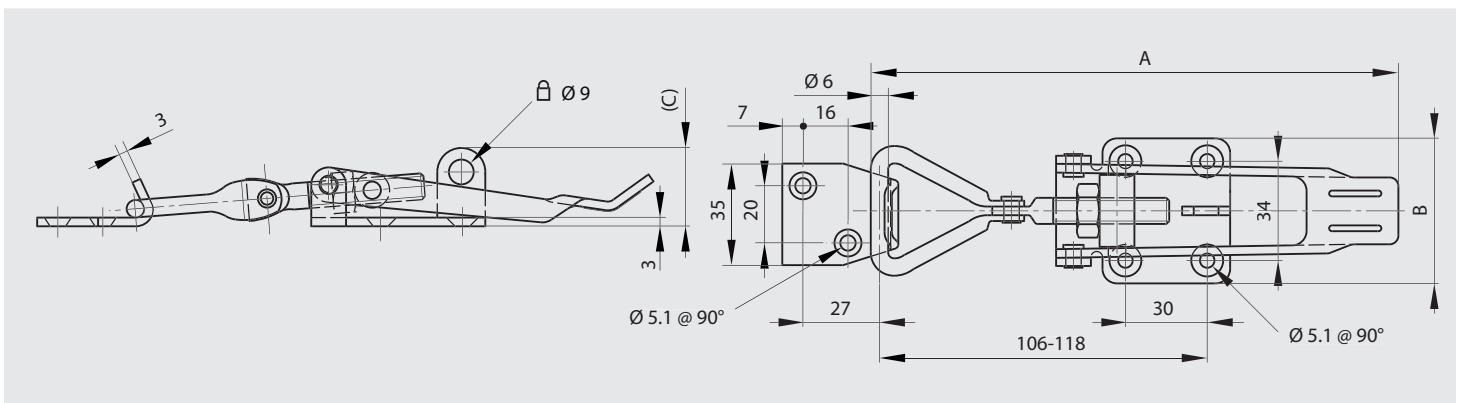



Toggles latches

Spring loaded toggle latch without strike 35.8 mm

This small latch is used with strike part number 16-7-3907.



Part number	Material	Finish	A	B	C	Weight (g)
16-7-3906	304 stainless steel	raw	35.8	12.3	7.9	9

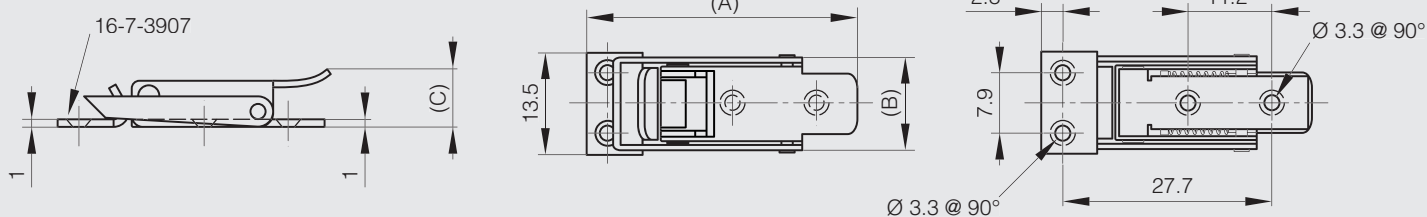

Strike for part number 16-7-3906



Part number	Material	Finish	Weight (g)
16-7-3907	304 stainless steel	raw	4.5





Toggles latches

Spring loaded toggle latches without strike - 70.8 mm

These latches are used with strike part number 16-7-3916.



Part number	Material	Finish	A	B	C	Note	Weight (g)
16-7-3911	304 stainless steel	raw	70.8	28.7	10.2		50
16-7-3920	304 stainless steel	raw	70.8	28.7	10.2	with seal wire hole	50

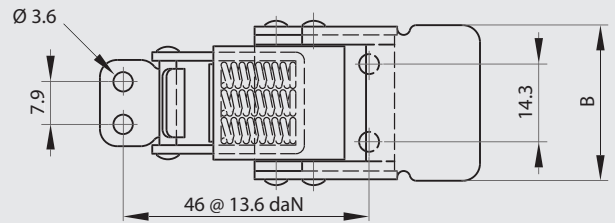
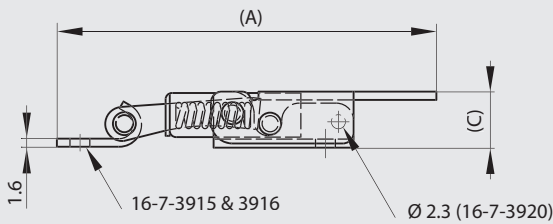

Spring loaded toggle latch without strike - with push button

The push button prevents accidental opening.

This latch is used with strike part numbers 16-7-3916.

A padlockable option is available for part number 16-7-3917.



Part number	Material	Finish	A	B	C	Note	Weight (g)
16-7-3918	304 stainless steel	raw	70.9	28.7	14.7	with push button to open / no seal wire hole	50

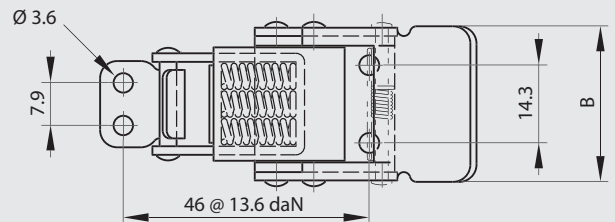
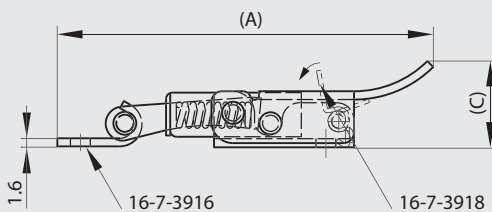

Strike for part numbers 16-7-3911, 16-7-3918 and 16-7-3920



Part number	Material	Finish	Weight (g)
16-7-3916	304 stainless steel	raw	4.5





Toggles latches

Spring loaded toggle latch without strike - 52 mm

This latch is used with strike part numbers 16-7-3739 and 16-7-3742. A padlockable option is available for part number 16-7-3760.



Part number	Material	Finish	A	B	C	Weight (g)
16-7-3736	304 stainless steel	raw	55.5	34.5	12	27

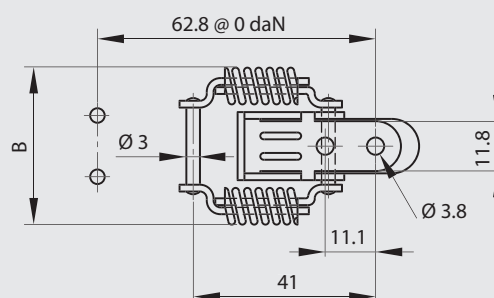
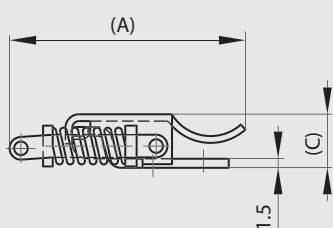

Strikes for part number 16-7-3736



Part number	Material	Finish	A	B	Note	Weight (g)
16-7-3739	304 stainless steel	raw	28.5	20.5	undrilled	3.5
16-7-3742	304 stainless steel	raw	28.5	20.5	drilled	3.5

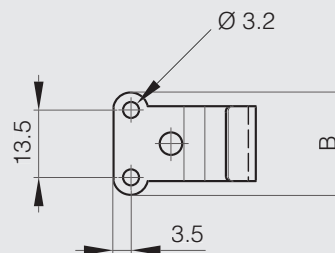
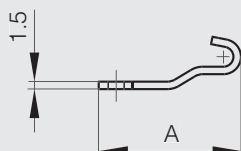



Toggles latches

Spring loaded toggle latches without strike - 74 mm

Dimension A (74 mm) without tension. Dimension A can be extended up to 4 mm putting the latch under tension.

These latches are used with strike part numbers 16-7-3751 and 16-7-3754.

A padlockable option is available for part number 16-7-3766.



Part number	Material	Finish	A	B	C	Note	Weight (g)
16-7-3745	304 stainless steel	raw	74	47	15	undrilled	70
16-7-3748	304 stainless steel	raw	74	47	15	drilled	70

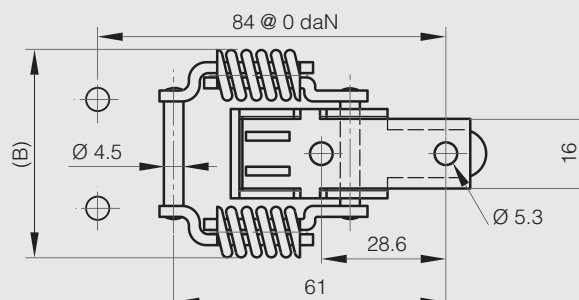
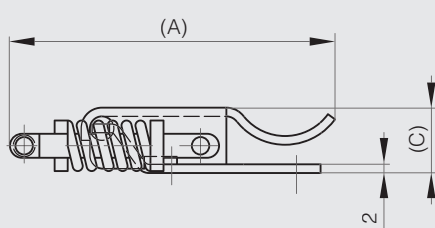

Strikes for part numbers 16-7-3745 and 16-7-3748



Part number	Material	Finish	A	B	Note	Weight (g)
16-7-3751	304 stainless steel	raw	36	40	undrilled	20
16-7-3754	304 stainless steel	raw	36	40	drilled	20

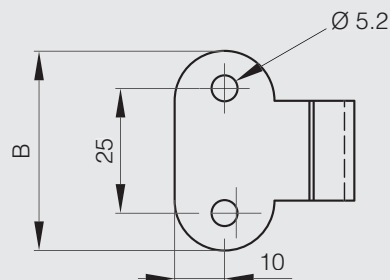
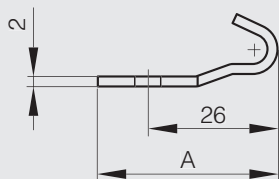



Toggles latches

Adjustable toggle latch with secondary lock and strike

STAINLESS
STEEL

✓
RoHS

Part number	Material	Finish	A	B	C	Weight (g)
16-1-9021	stainless steel	electropolished	70	27.5	13.5	77

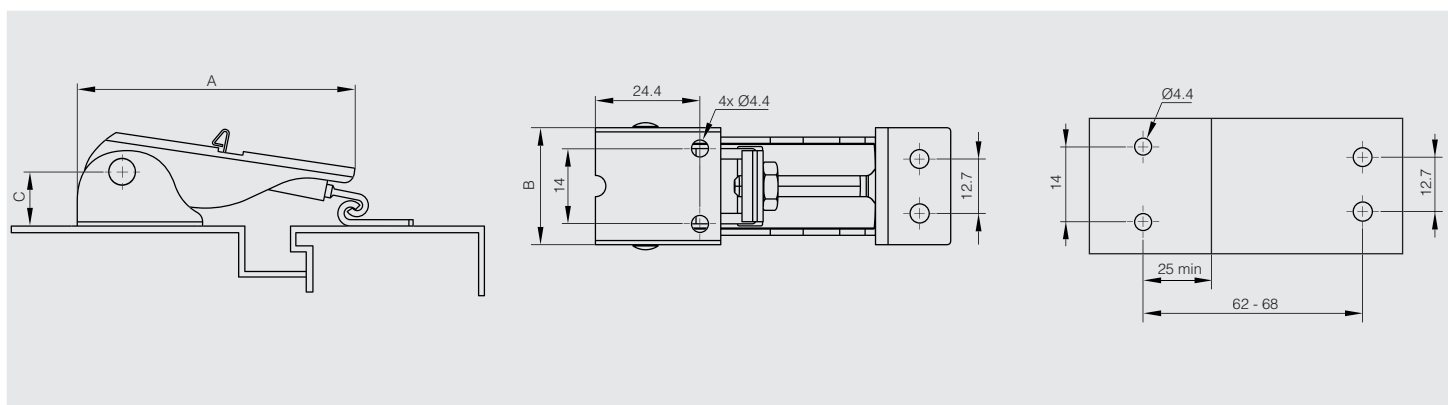



Toggles latches

Adjustable toggle latch without strike 70.6 mm

These latches are used with strike part number 16-7-3940.

Part number 16-7-3934 has a lockable nut.

STAINLESS
STEEL

Part number	Material	Finish	A	B	C	Weight (g)
16-7-3933	304 stainless steel	raw	70.6	28.2	16	50

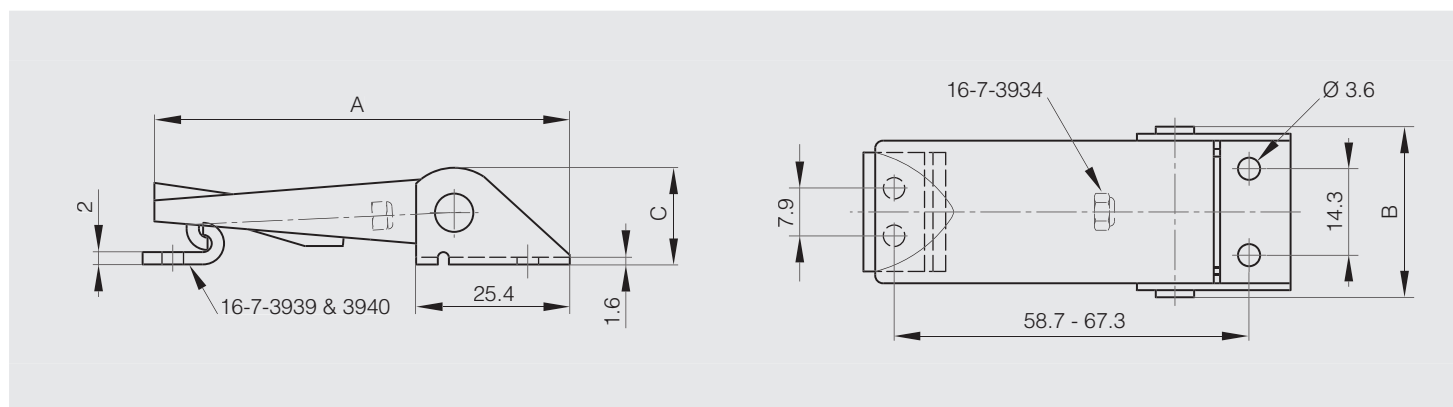

Strike for part number 16-7-3933

STAINLESS
STEEL

Part number	Material	Finish	Weight (g)
16-7-3940	304 stainless steel	raw	4.5





Stainless steel range - Latching systems

Toggles latches

Adjustable toggle latches with strike 82 mm and 103 mm long



Part number	Material	Finish	A	B	C	C1	C2	D	E	F	G	H	J	S	Note	Weight (g)
16-7-4024	304 stainless steel	raw	82	28	14	2	2	4	14	5	10	52-59	18	4	82<A<89	46
16-7-4026	304 stainless steel	raw	103	34	16	2.5	3	5	17	6.5	10	68-86	17	5.2	103<A<121	90

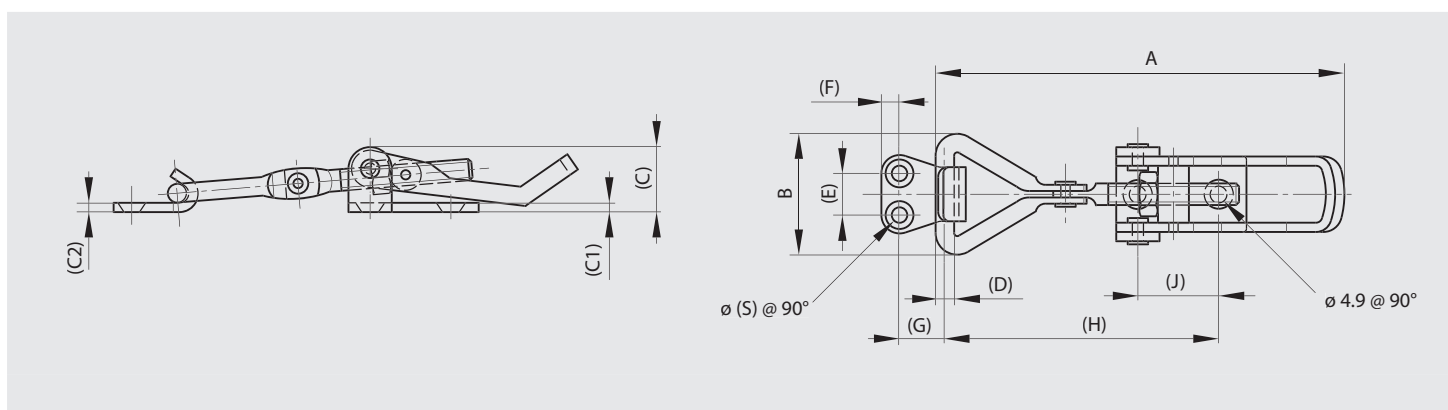

Adjustable toggle latch with strike 118 mm



Part number	Material	Finish	A	B	C	Note	Weight (g)
16-7-4029	304 stainless steel	raw	118	40	18	118<A<128	130

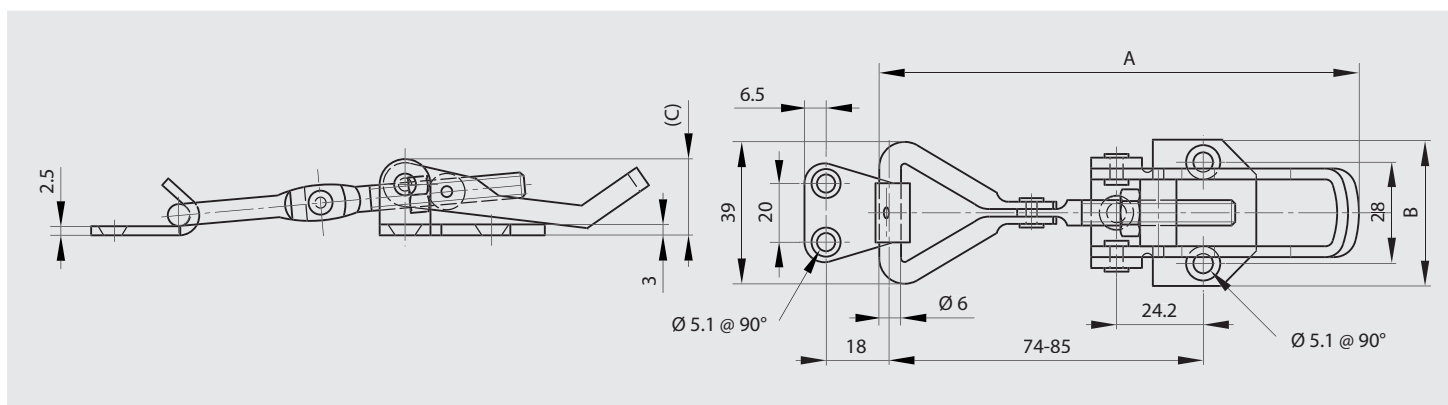



Toggles latches

Adjustable toggle latch with strike 88 mm



Part number	Material	Finish	A	B	C	Weight (g)
16-7-3844	304 stainless steel	raw	88	48.5	26	174

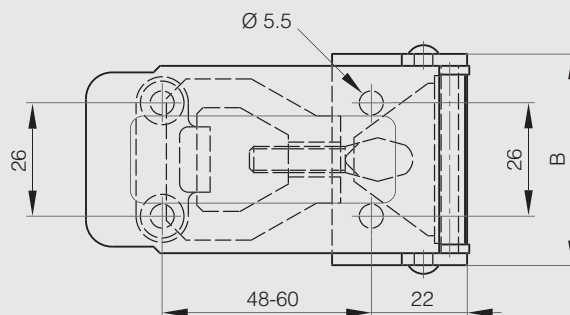
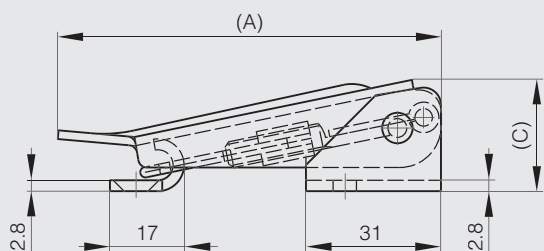

Adjustable toggle latch with strike 138 mm

Dimension A is adjustable from 138 mm to 150 mm.



Part number	Material	Finish	A	B	C	Note	Weight (g)
16-7-3841	304 stainless steel	raw	138	52	18	138<A<150	100

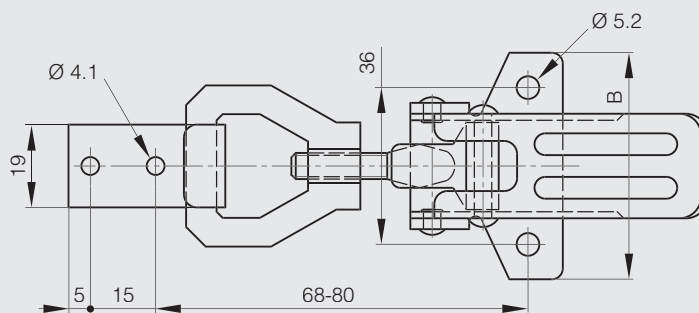
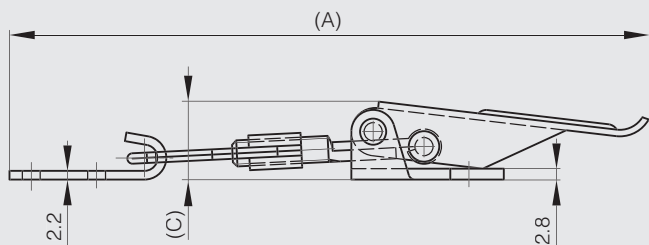



Toggles latches

Adjustable toggle latch with secondary lock without strike

Dimension A is adjustable from 115 mm to 122 mm.



Part number	Material	Finish	A	B	C	Note	Weight (g)
16-1-4231	304 stainless steel	raw	115	52	22	115<A<122	85

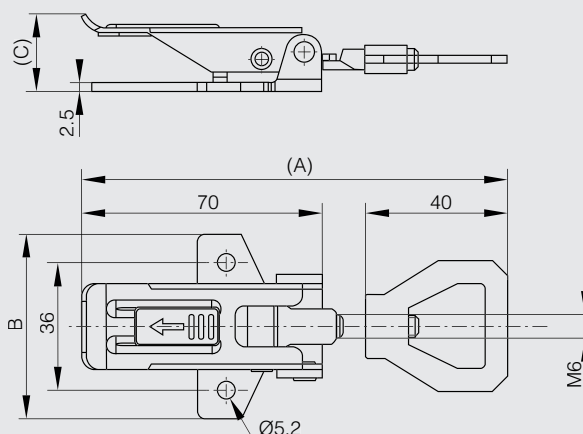

Strike for part number 16-1-4231



Part number	Material	Finish	A	B	Weight (g)
16-1-4236	304 stainless steel	raw	67	57.9	35

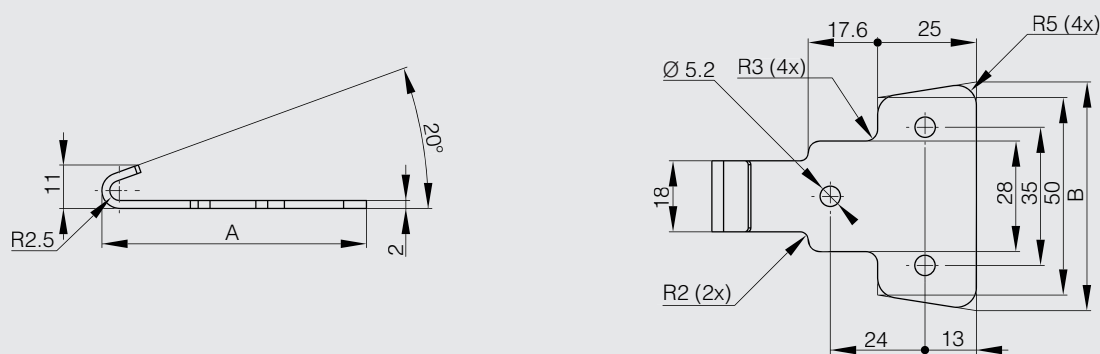



Toggles latches

Other strikes for part number 16-1-4231



Part number	Material	Finish	A	B	Note	Weight (g)
16-7-3751	304 stainless steel	raw	36	40	undrilled	20
16-7-3754	304 stainless steel	raw	36	40	drilled	20

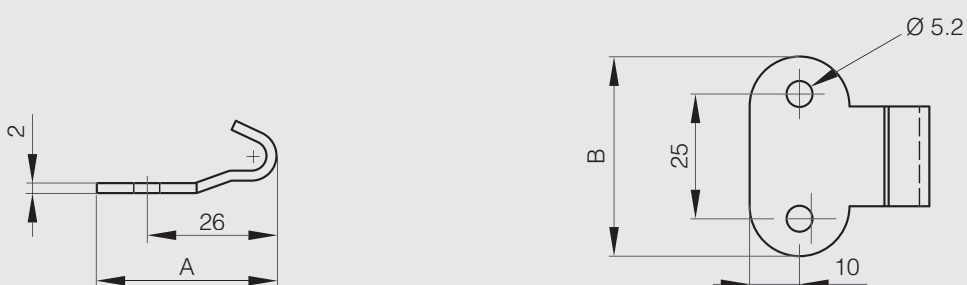

Toggle latch without strike 62.5 mm



Part number	Material	Finish	A	B	C	Weight (g)
16-7-3900	304 stainless steel	raw	62.5	24.4	13.5	27

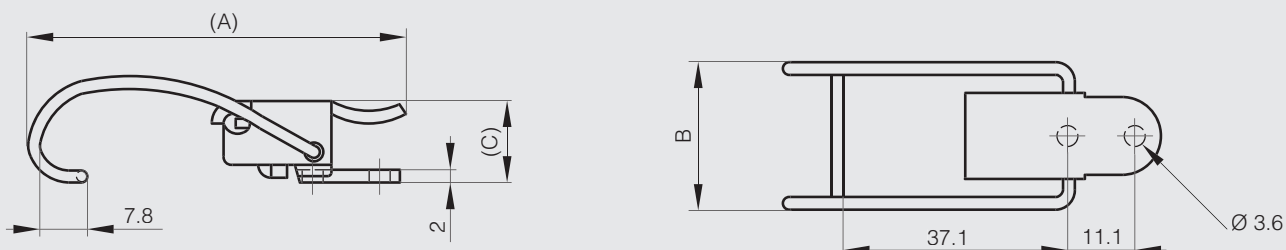



Toggles latches

Toggle latch without strike - 64 mm



Part number	Material	Finish	A	B	C	Weight (g)
16-7-3948	stainless steel	raw	64	28.7	14	45

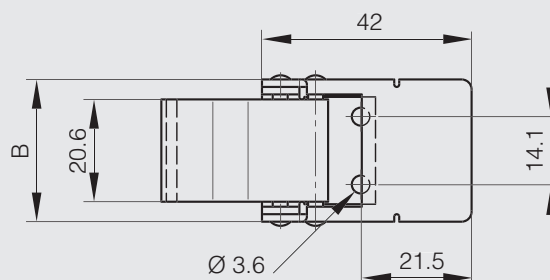
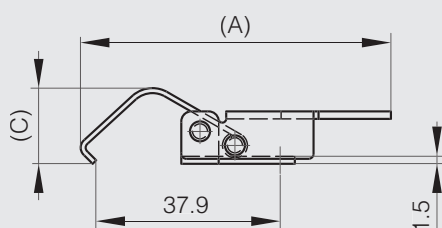

Toggle latch without strike - 67.6 mm



Part number	Material	Finish	A	B	C	Weight (g)
16-7-3902	304 stainless steel	raw	67.6	25.4	13.7	32

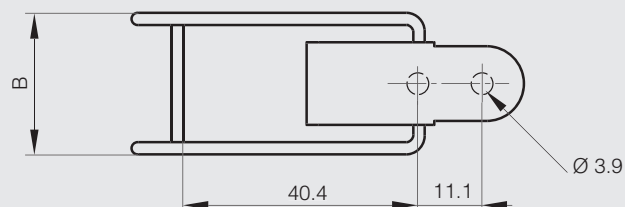
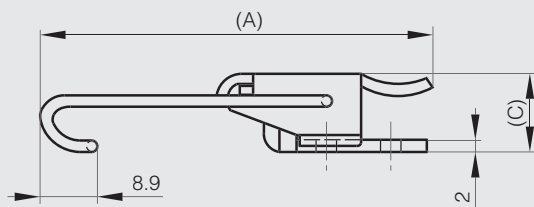



Toggles latches

Toggle latch without strike - 93.2 mm



Part number	Material	Finish	A	B	C	Weight (g)
16-7-3903	304 stainless steel	raw	93.2	25.4	13.7	32

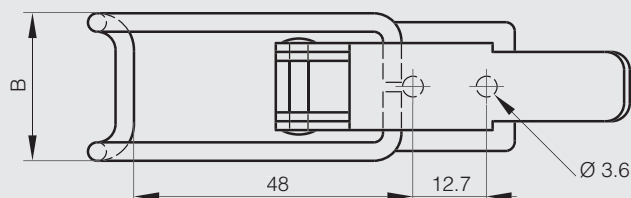
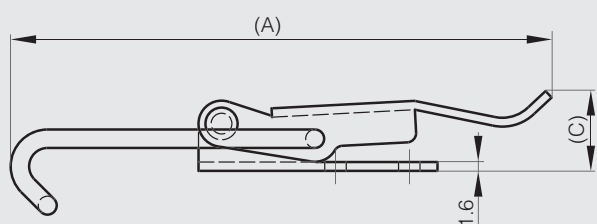

Hooked toggle latch without strike



Part number	Material	Finish	A	B	C	Note	Weight (g)
NEW 16-1-4261	304 stainless steel	raw	80	27	32.1	80<A<107	82

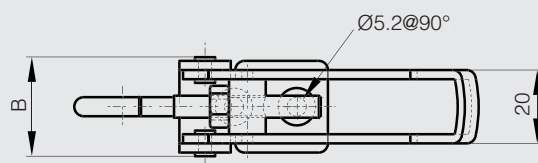
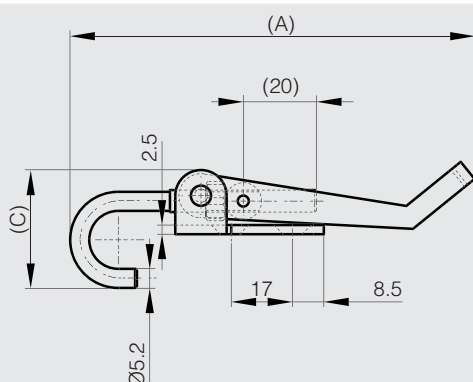



Alternative strike for toggle latches

STAINLESS
STEEL



Part number	Material	Finish	A	B	Weight (g)
16-7-3872	304 stainless steel	raw	21.4	22.4	9

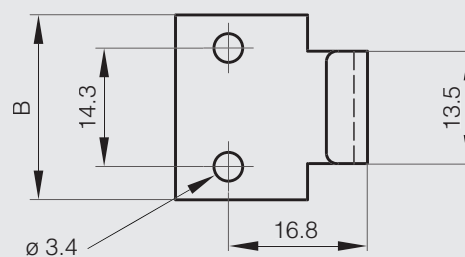
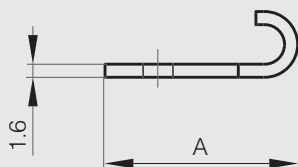



Grab handles

Front mounted grab handle 88 mm

Complete with wood screws.



Part number	Material	Finish	A	B	F	Weight (g)
19-7-3693	304 stainless steel	mirror polished	88	25	100	68.5

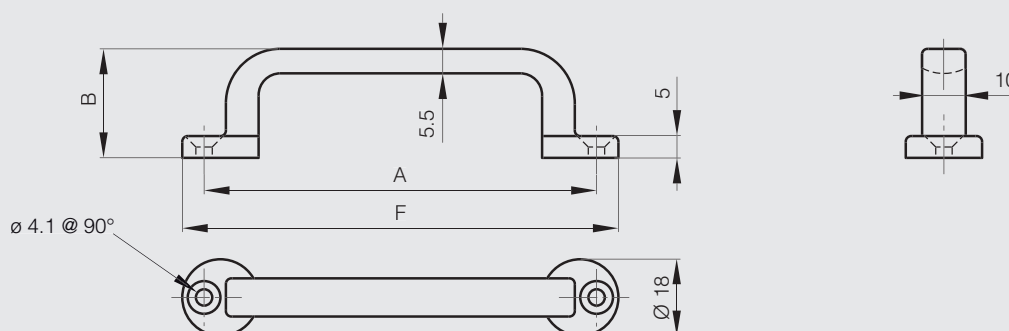

Front mounted grab handles 107 mm in steel or stainless steel



Part number	Material	Finish	A	B	C	F	Weight (g)
19-1-3797	304 stainless steel	deburred	107	21	15	120	32





Grab handles

Front mounted grab handles 106 and 126 mm

Complete with wood screws.



Part number	Material	Finish	A	B	C	D	E	F	G	H	S	Weight (g)
19-7-3694	304 stainless steel	mirror polished	106	27	24	7	5	120	24	12	4.1	131
19-7-3695	304 stainless steel	mirror polished	126	33	30	8	6	150	30	15	5.3	242

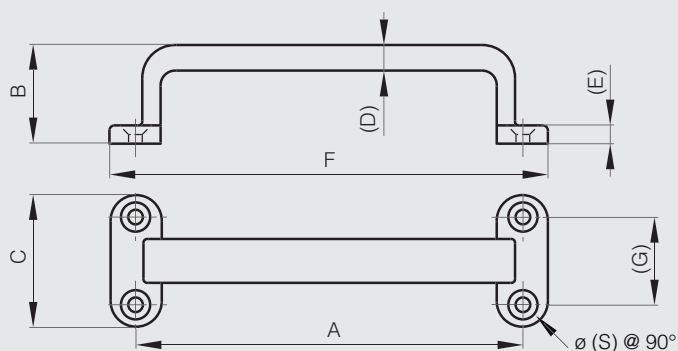

Rear mounted grab handles 110 mm



Part number	Material	Finish	A	B	D	L	M	Weight (g)
19-1-3424	304 stainless steel	polished	110	35	8	11	5	61

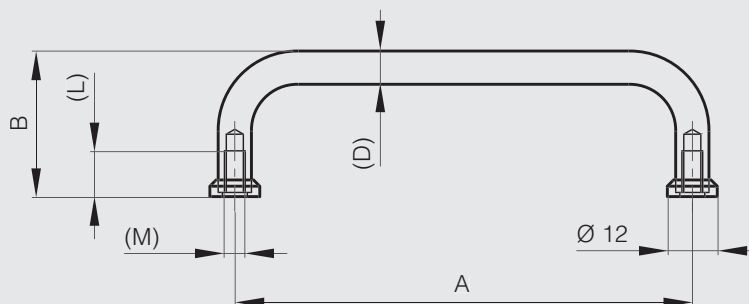



Rear mounted grab handles 95 to 150 mm

For use with M4 screws.

STAINLESS
STEEL

Part number	Material	Finish	A	B	D	L	M	Weight (g)
19-7-3701	304 stainless steel	mirror polished	95	28	9	8	4	76
19-7-3700	304 stainless steel	mirror polished	120	28	9	8	4	88
19-7-3699	304 stainless steel	mirror polished	150	28	9	8	4	103

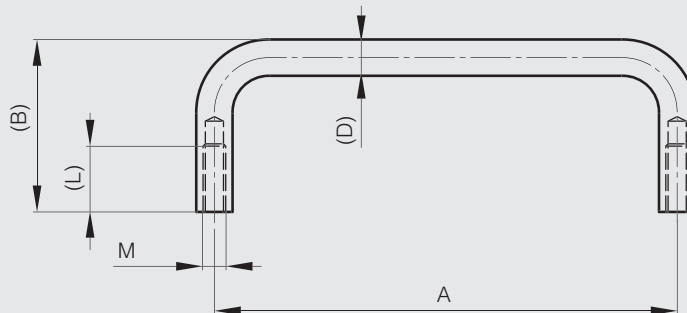

Rear mounted grab handles 92 to 200 mm

Complete with M5 screws for 304 stainless steel version.

STAINLESS
STEEL

Part number	Material	Finish	A	B	C	D	L	Weight (g)
19-1-3833	316 stainless steel	mirror polished	92	32	14.8	7.8	10	120
19-7-3696	304 stainless steel	mirror polished	100	40	14	8	11	120
19-1-3834	316 stainless steel	mirror polished	110	32	14.8	7.8	10	120
19-7-3697	304 stainless steel	mirror polished	150	50	14	8	11	174
19-7-3698	304 stainless steel	mirror polished	200	50	14	8	11	210

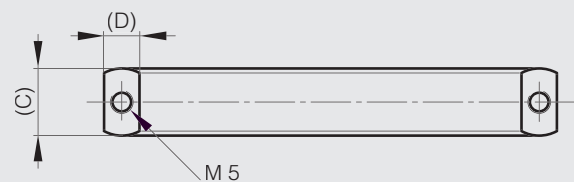
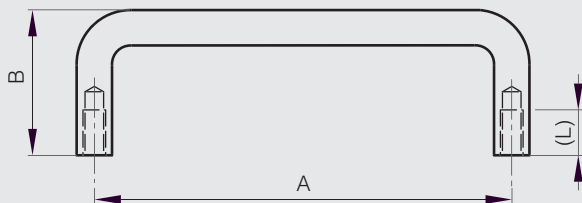



Drop handles

Drop handle with chamfredded angles - load 35 kg

With 90° stop.



Part number	Material	Finish	A	B	C	D	E	S	Note	Weight (g)
19-7-3690	304 stainless steel	raw	158	54	130	89	7	5.2	load: 35 kg / chamfredded angles	120

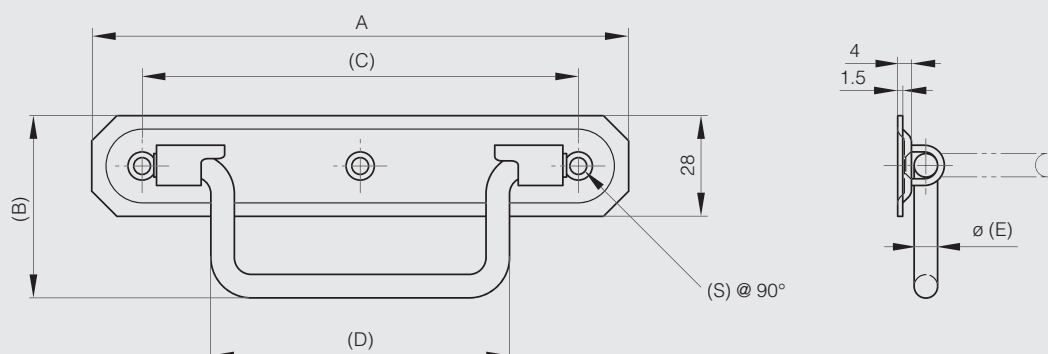

Spring loaded handles - load 34 kg - 180° opening

Maximum load: 34 kg.

With 180° stop.

Rubber grip in EPDM.



Part number	Material	Finish	A	B	C	Weight (g)
19-7-3711	stainless steel	passivated	130	75.4	46	227

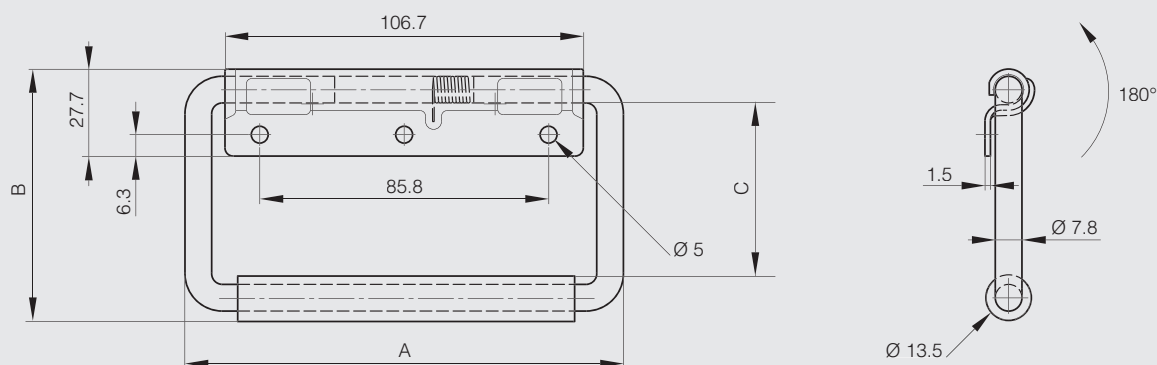



Drop handles

Spring loaded handles 130.3 mm - load 45 kg

Maximum load: 45 kg.
 With 90° stop.
 Rubber grip.

STAINLESS STEEL

Part number	Material	Finish	A	B	C	E	Weight (g)
19-7-3746	stainless steel	raw	130.3	82.6	38.1	41.9	272
19-7-3741	stainless steel	raw	130.3	104.1	60.4	41.9	272

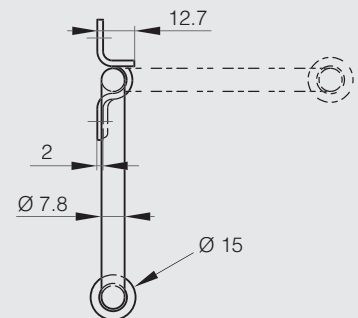
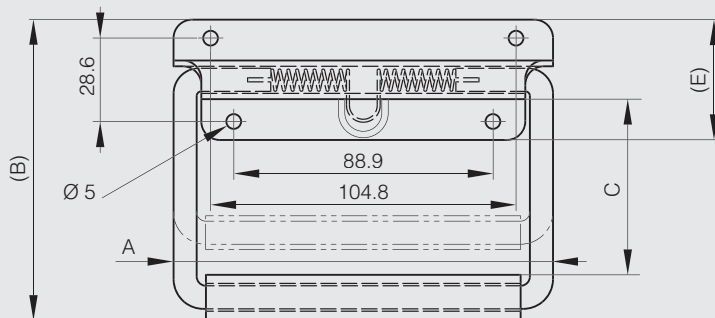

Spring loaded handle 130 mm - load 54 kg

Maximum load: 54 kg.
 With 90° stop.

STAINLESS STEEL RoHS

A special aluminium sleeve located between the rubber grip and the bail assures the grip will not ride up on the bail during lifting. Adds comfort and durability.
 Fungus resistant neoprene.
 Meets military specifications MIL.T.945, MIL.C.4150.

Part number	Material	Finish	A	B	C	Weight (g)
19-7-3725	stainless steel	raw	130	112.7	50.8	317

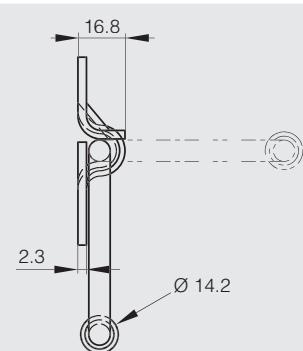
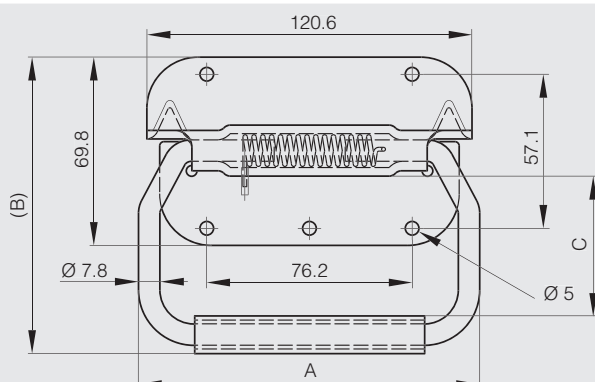



Flush handles

Retractable flush handles in stainless steel



Part number	Material	Finish	A	B	C	D	E	F	Weight (g)
NEW 19-7-3813	304 stainless steel	satin	76	36	24	60	18	90	46
19-7-3814	304 stainless steel	satin	94	42	24	72	18	110	55

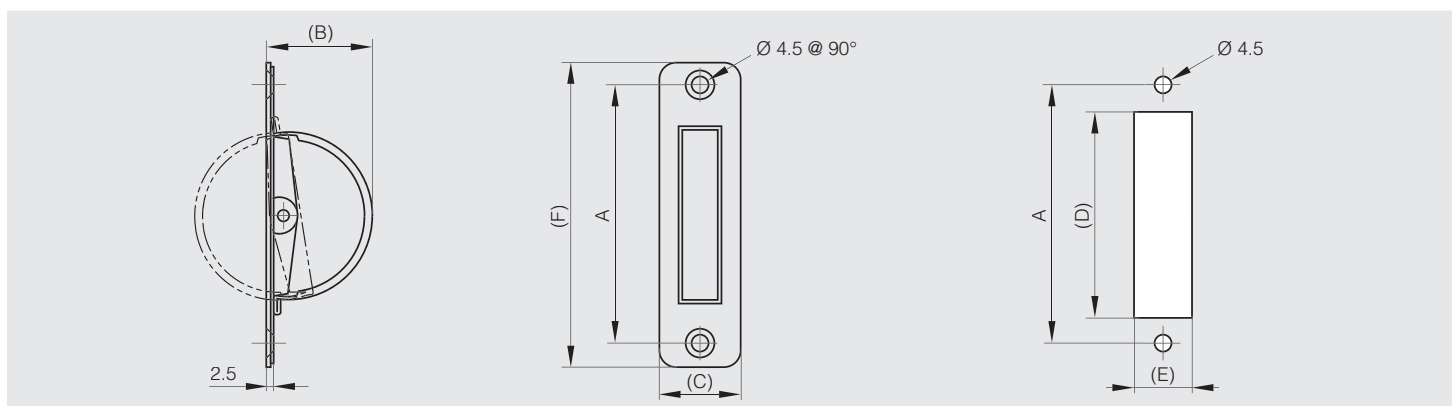

Bolt-on flush handle 120 x 60 mm



Part number	Material	Finish	A	B	C	Weight (g)
19-7-3831	304 stainless steel	satin	120	60	15	54

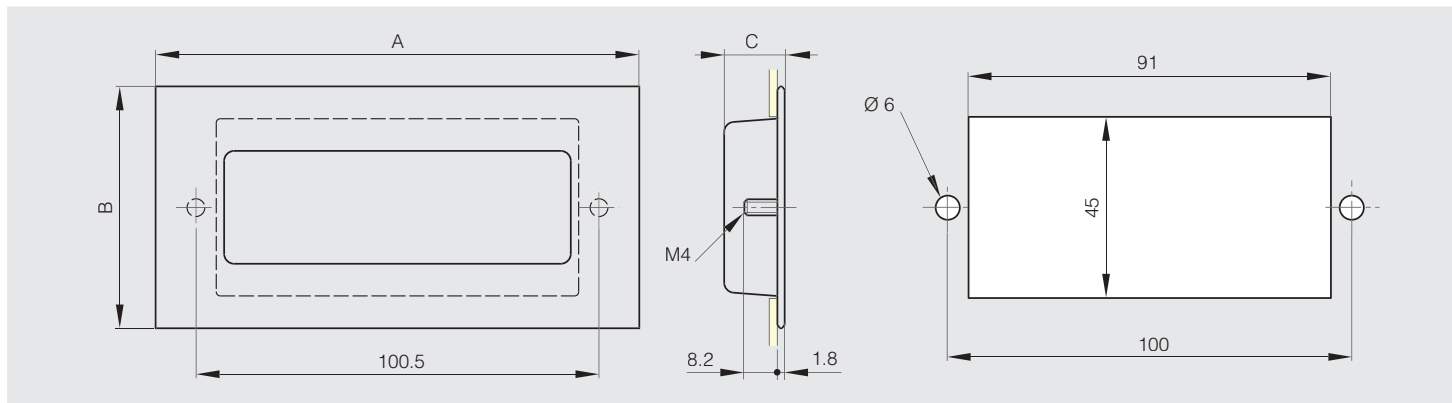



Flush handles

Bolt-on flush handle 120 x 62 mm

Bolt in copper plated steel.

STAINLESS STEEL

Part number	Material	Finish	A	B	C	Weight (g)
19-7-3832	304 stainless steel	satin	120	62	16	60

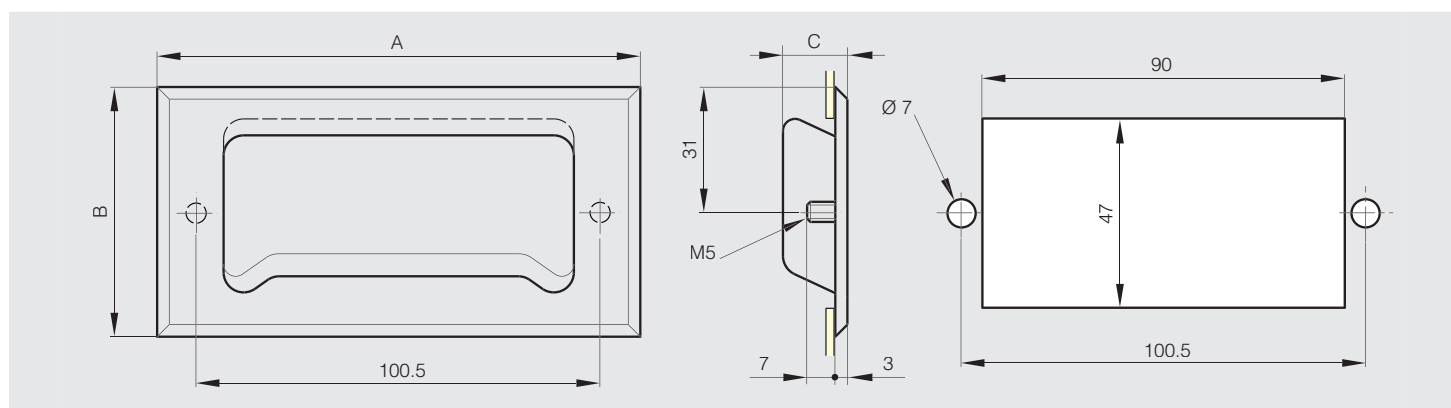

Bolt-on flush handle 138 x 88 mm

Stud in 304 stainless steel.



STAINLESS STEEL RoHS

Part number	Material	Finish	A	B	C	Weight (g)
NEW 19-7-3845	304 stainless steel	satin	138	88	26	170

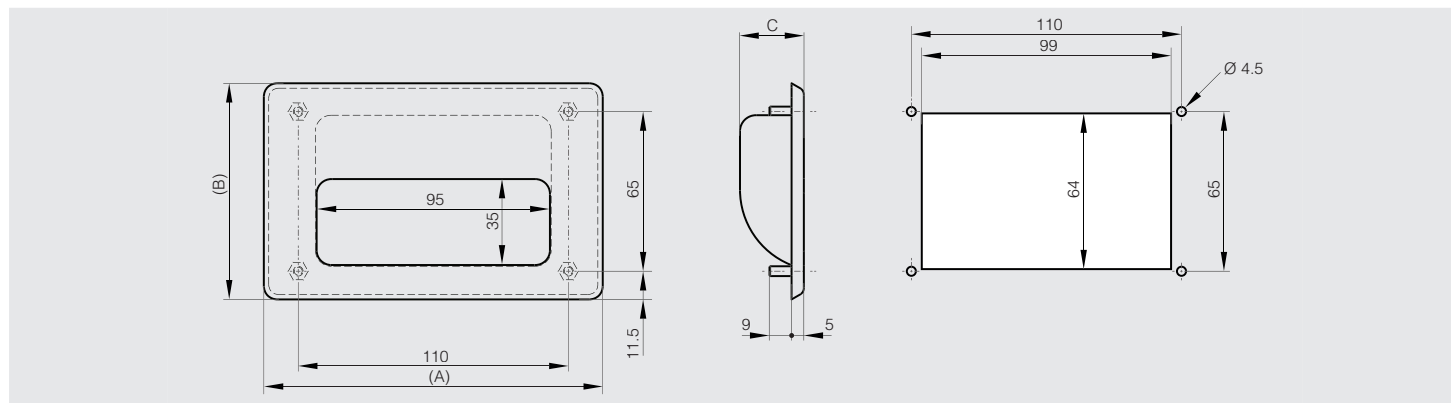



Support stays

Support stays with automatic release - small size

Load capacity: 6 kg.



Part number	Material	Finish	A	B	C	D	K	Weight (g)
24-7-3577	304 stainless steel	raw	67	100	15.4	8.8	32	10
24-7-3571	304 stainless steel	raw	88	140	15.4	8.8	52	40

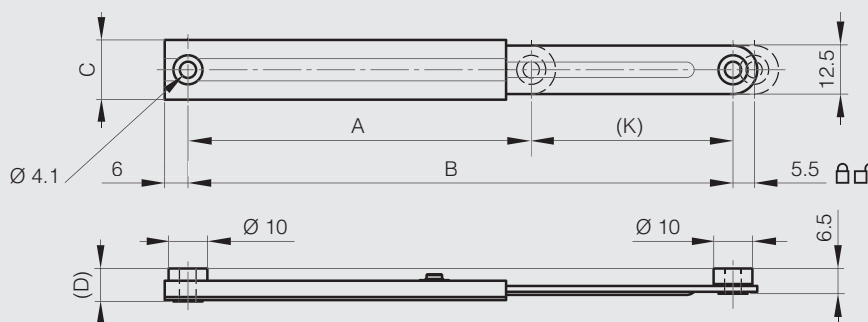

Support stays with automatic release in stainless steel

Load capacity: 15 kg.



Part number	Material	Finish	A	B	Weight (g)
24-7-3552	304 stainless steel	satin	133	195	125
24-7-3553	304 stainless steel	satin	170	270	150

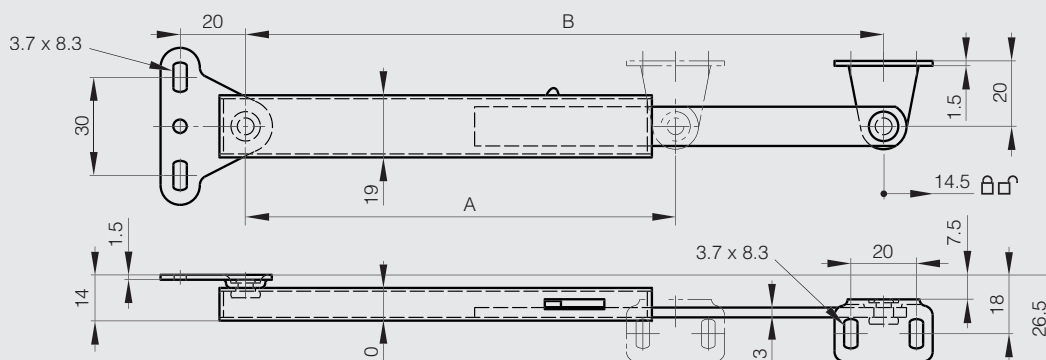



Support stays

Support stays with manual release



A = closed dimension.

B = extended dimension.

Load capacity: 50 kg.

Push button release.

Part number	Material	Finish	A	B	Weight (g)
24-1-3558	304 stainless steel	raw	125	175	101
24-1-3559	304 stainless steel	raw	150	225	125
24-1-3560	304 stainless steel	raw	175	275	145

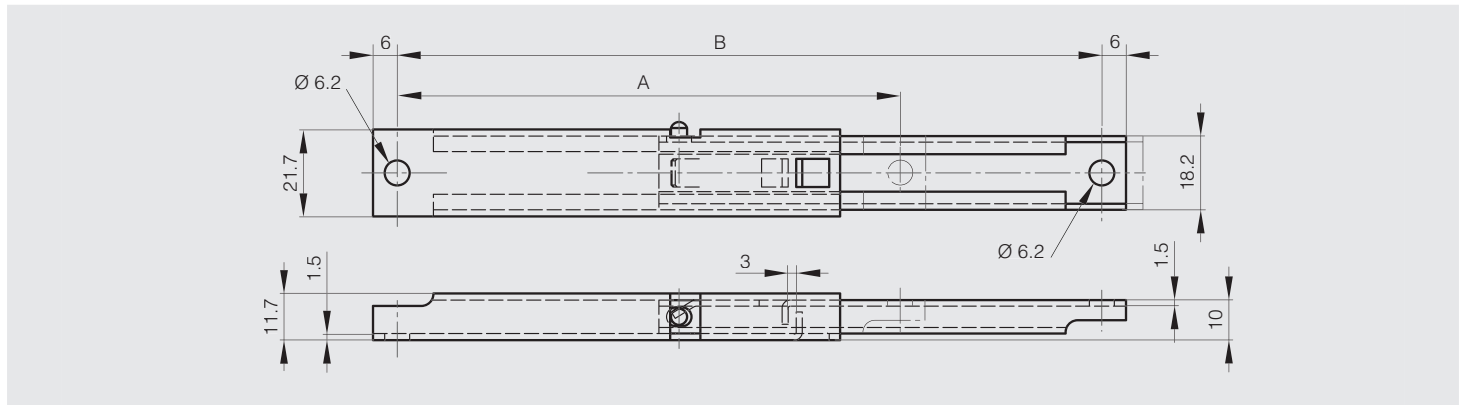

Bracket



Complete with M6 screw, M6 nut and 3 mm thick washer.

For part numbers 24-1-3558, 24-1-3559 and 24-1-3560.

Part number	Material	Finish	A	B	Weight (g)
99-1-3558	stainless steel	raw	50	26	54

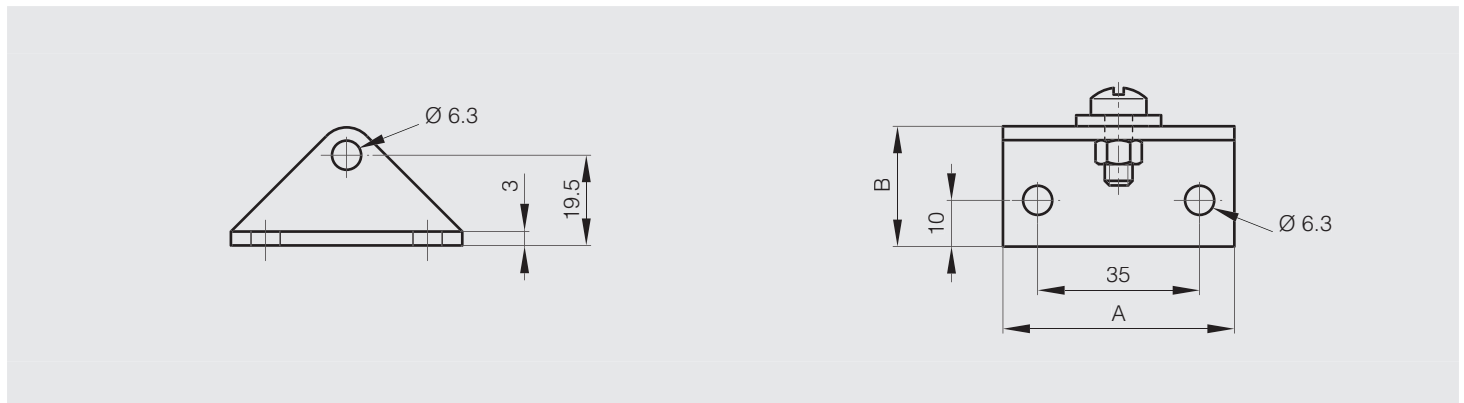



Support stays

Multi-angle lid stay with lock

Locks lid in multiple positions by manually sliding lock lever.
 Slide back lever to lock / unlock.
 Ideal for vibration or shock applications.
 Can be installed individually or in pairs.
 Non-handed: can be installed on left or right side.
 Compression load: max. 290 N.

STAINLESS STEEL



Part number	Material	Finish	A	B	Weight (g)
24-7-3580	304 stainless steel	satin	224	350	325

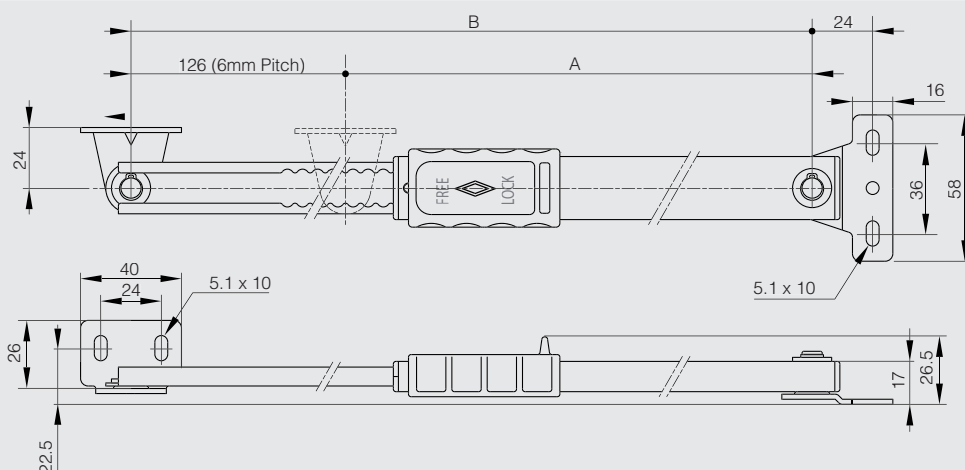

Support stay

For holding lids or panels in open position (vertical to horizontal).

STAINLESS STEEL RoHS

Part number	Material	Finish	A	B	Weight (g)
24-7-3546	304 stainless steel	satin	210	180	89.5
24-7-3547	304 stainless steel	satin	240	210	94.5
24-7-3548	304 stainless steel	satin	270	240	106.5

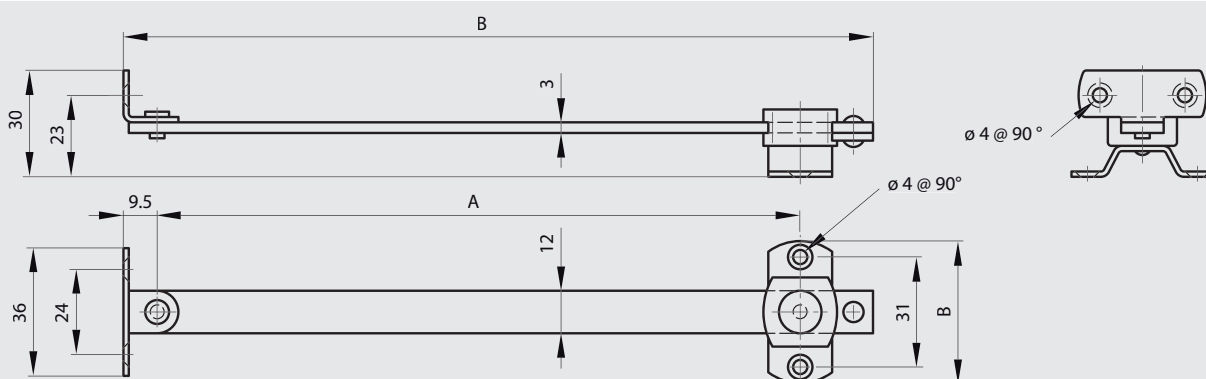



Lid stays

Heavy duty spring loaded stay



- Spring mechanism assists in lifting door and holds in open position (10° to 80°).
- Can be installed individually or in pairs.
- Non-handed: can be installed on left or right side.
- Torque calculation:

Torque (N.m) = H(m) x 1/2 x W (kg) x 9.8 with:

- H = door height (m).
- W = door weight (kg).



Part number	Material	Finish	A	Torque	Weight (g)
24-7-3579	430 stainless steel	raw	94.2	8.8 - 11.8 N.m	195

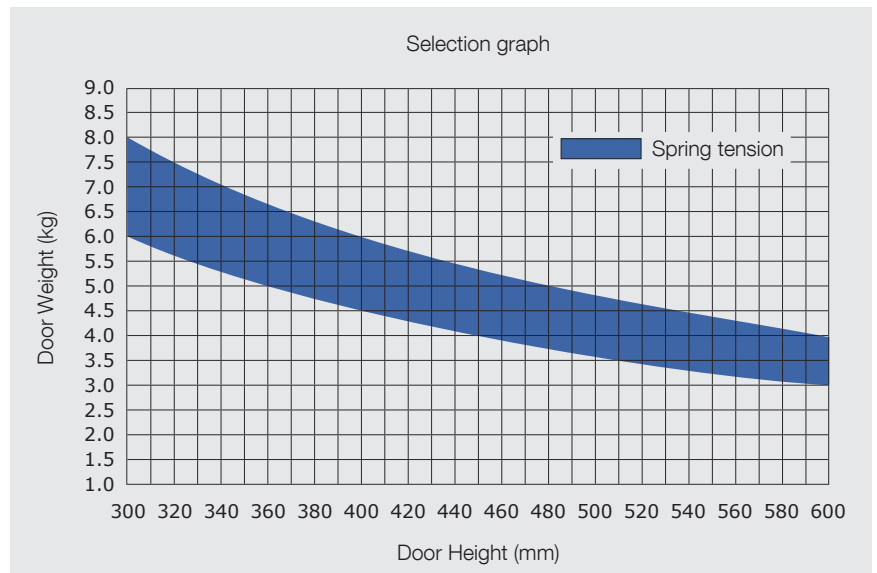
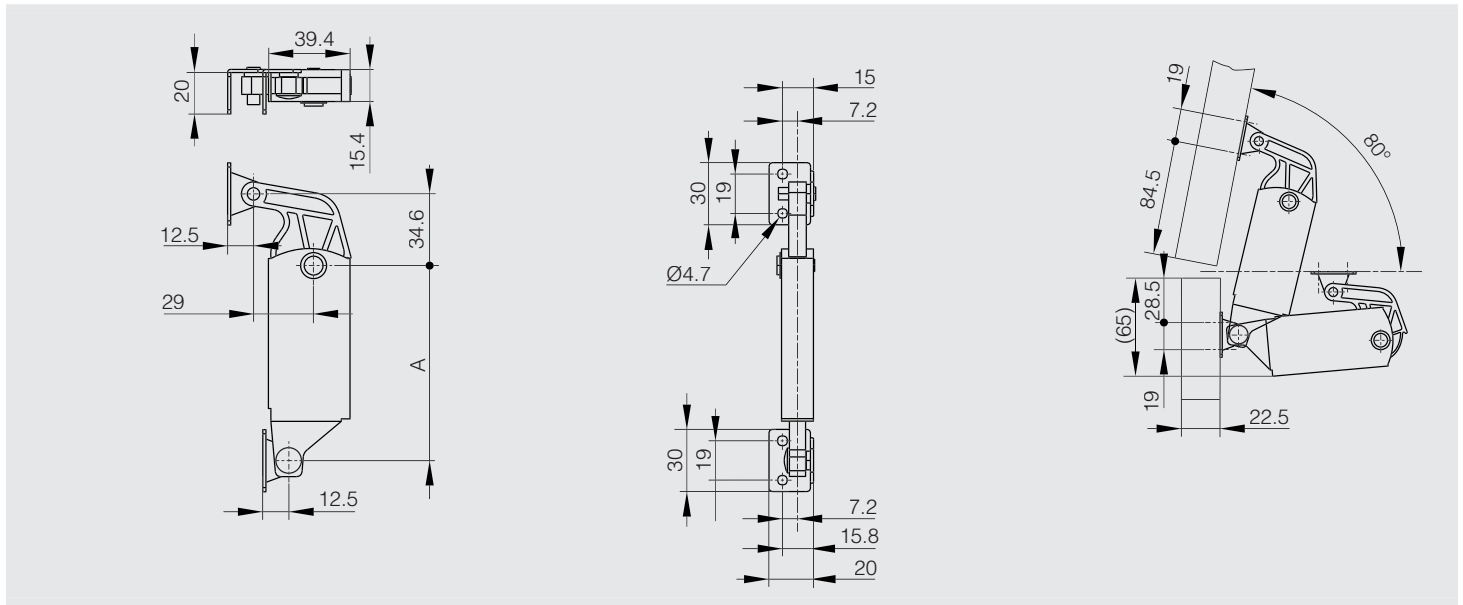



Lid stays

Stay with safety stop

STAINLESS STEEL RoHS

Part number	Material	Finish	A	B	Weight (g)
24-1-9000	304 stainless steel	raw	139	151	148
24-1-9001	304 stainless steel	raw	139	151	148

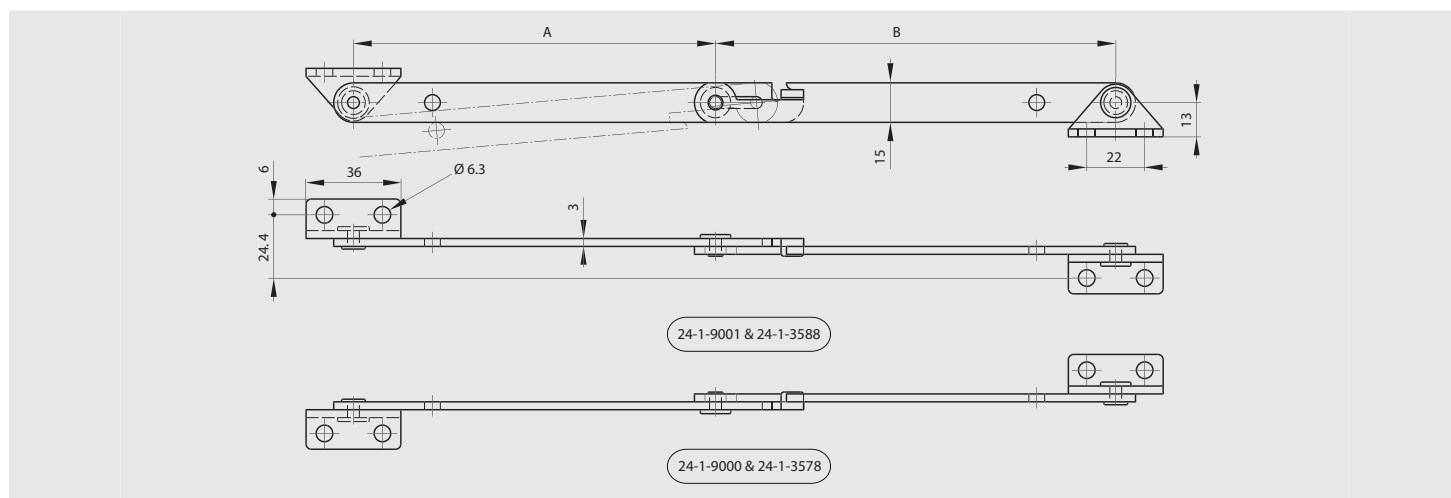

Stays without bracket

STAINLESS STEEL RoHS

Part number	Material	Finish	A	Weight (g)
24-1-0247	304 stainless steel	polished	102	35
24-1-0248	304 stainless steel	polished	102	35

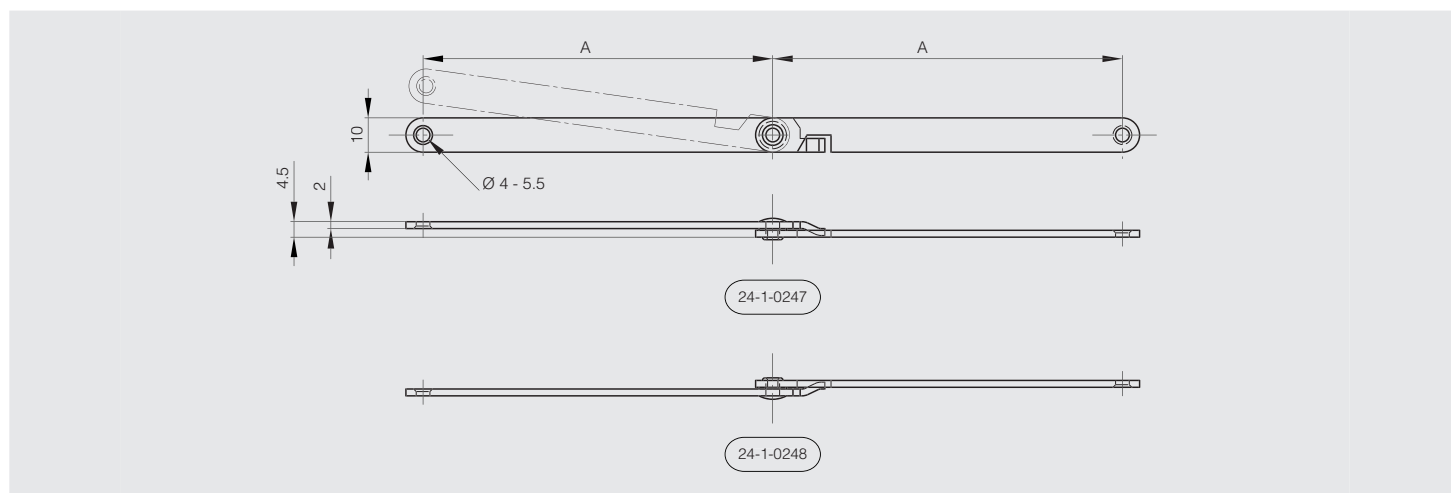



Lid stays

Folding bracket

Automatically locks when flap is in opened position.

Press lever to release the lock.

Bracket with hinge function in one unit.

Load capacity: 150 kg.



	Part number	Material	Finish	A	B	C	Weight (g)
NEW	24-7-3587	304 stainless steel	polished	305.5	165	29	515

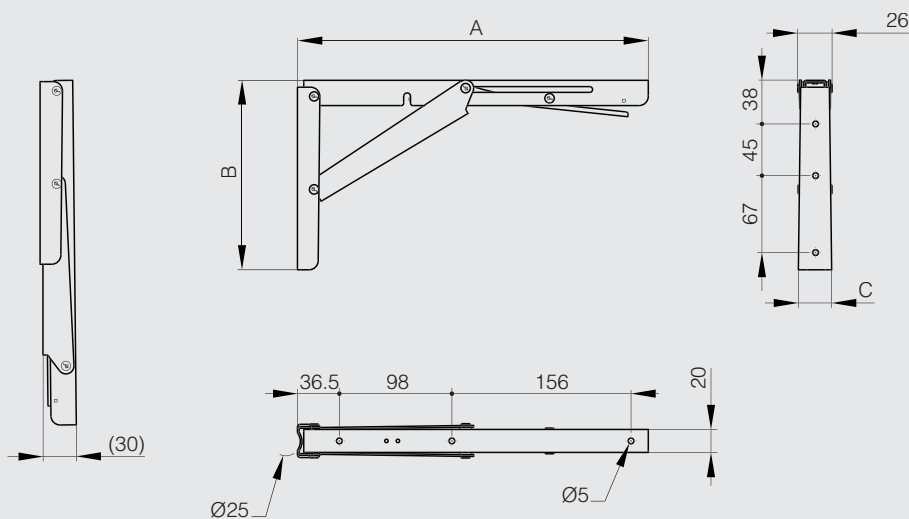



Door holder

Door holders

Automatically locks door when fully opened. Slide the locking lever to release the lock.

Tensile force: Max 1500 N.

Compression load: Max 600 N.

Handed: specific left and right hand mounting.

STAINLESS
STEEL

Part number	Material	Finish	A	Weight (g)
22-7-3547	304 stainless steel	polished	200	630
22-7-3548	304 stainless steel	polished	200	630

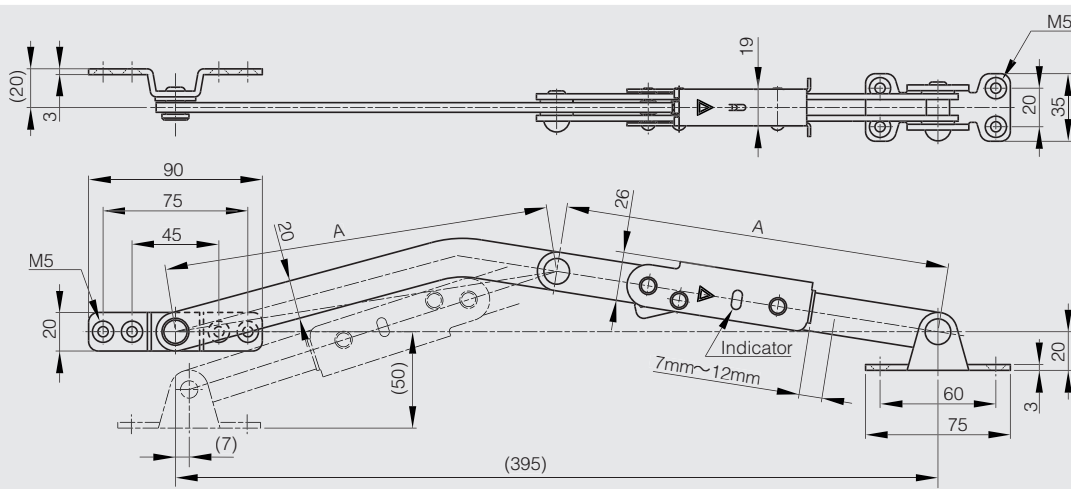

22-7-3547

22-7-3548



Telescopic slides

3/4 extension ball-bearing slide (2 pieces), front disconnect



LG = slide length.

K = travel length.

CN = load rating (kg/pair).



Part number	Material	Finish	K	LG	A	B	C	D	E	F	G	CN	Weight (g)
21-7-3576	304 stainless steel	raw	228.6	304.8	-	149.2	260.3	273	-	152.4	254	49	300
21-7-3577	304 stainless steel	raw	279.4	355.6	-	200	311.1	323.8	-	203.2	304.8	47	360
21-7-3562	304 stainless steel	raw	304.8	406.4	-	250.8	361.9	374.6	-	254	359.6	43	420
21-7-3563	304 stainless steel	raw	330.2	457.2	212.7	301.6	412.7	425.4	203.2	304.8	406.4	41	460
21-7-3564	304 stainless steel	raw	382	508	238.1	352.4	463.5	476.2	228.6	355.6	457.2	37	490
21-7-3565	304 stainless steel	raw	406.4	558.8	263.5	403.2	514.3	527	254	406.4	508	34	560
21-7-3566	304 stainless steel	raw	432.8	609.6	288.9	454	565.1	577.8	279.4	457.2	558.8	30	590
21-7-3567	304 stainless steel	raw	482.6	660.4	314.3	504.8	615.9	628.6	304.8	508	609.6	27	660
21-7-3568	304 stainless steel	raw	508	711.2	339.7	555.6	666.7	679.4	330.2	558.8	660.4	25	690

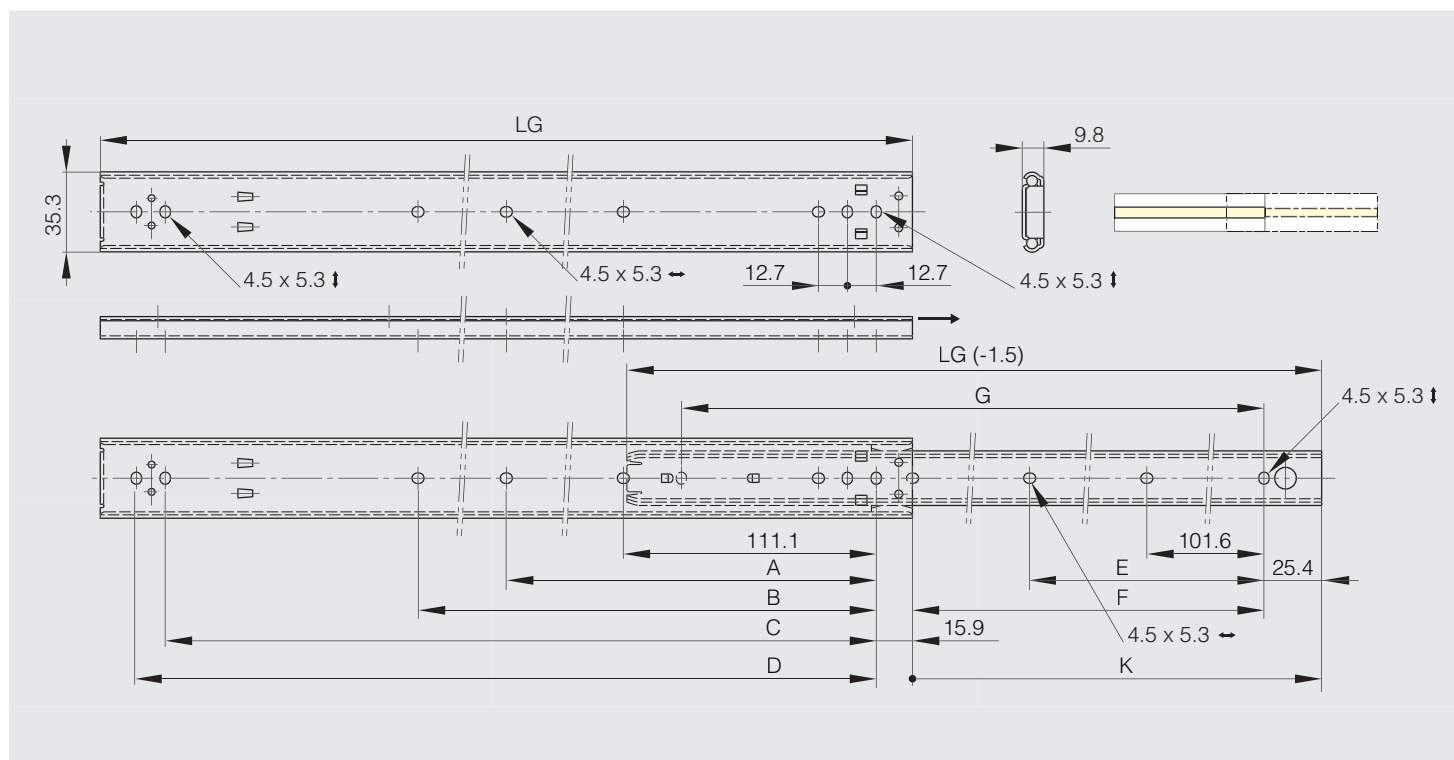



Telescopic slides

Full extension ball-bearing slide (3 pieces), front disconnect and positive lock



LG = slide length.

K = travel length.

CN = load rating (kg/pair).



Part number	Material	Finish	K	LG	A	B	C	D	E	F	G	H	CN	Weight (g)
21-7-3569	304 stainless steel	raw	421.7	406.4	250.8	361.9	374.6	-	-	349.2	361.9	374.6	57	840
21-7-3570	304 stainless steel	raw	472.5	457.2	301.6	412.7	425.4	212.7	-	400	412.7	425.4	53	950
21-7-3571	304 stainless steel	raw	523.3	508	352.4	463.5	476.2	238.1	-	450.8	463.5	476.2	49	1030
21-7-3572	304 stainless steel	raw	574.1	558.8	403.2	514.3	527	263.5	415.9	501.6	514.3	527	45	1150
21-7-3573	304 stainless steel	raw	624.9	609.6	454	565.1	577.8	288.9	466.7	552.4	565.1	577.8	42	1280
21-7-3574	304 stainless steel	raw	675.7	660.4	504.8	615.9	628.6	314.3	517.5	603.2	615.9	628.6	39	1400
21-7-3575	304 stainless steel	raw	726.5	711.2	555.6	666.7	679.4	339.7	568.3	654	666.7	679.4	36	1500

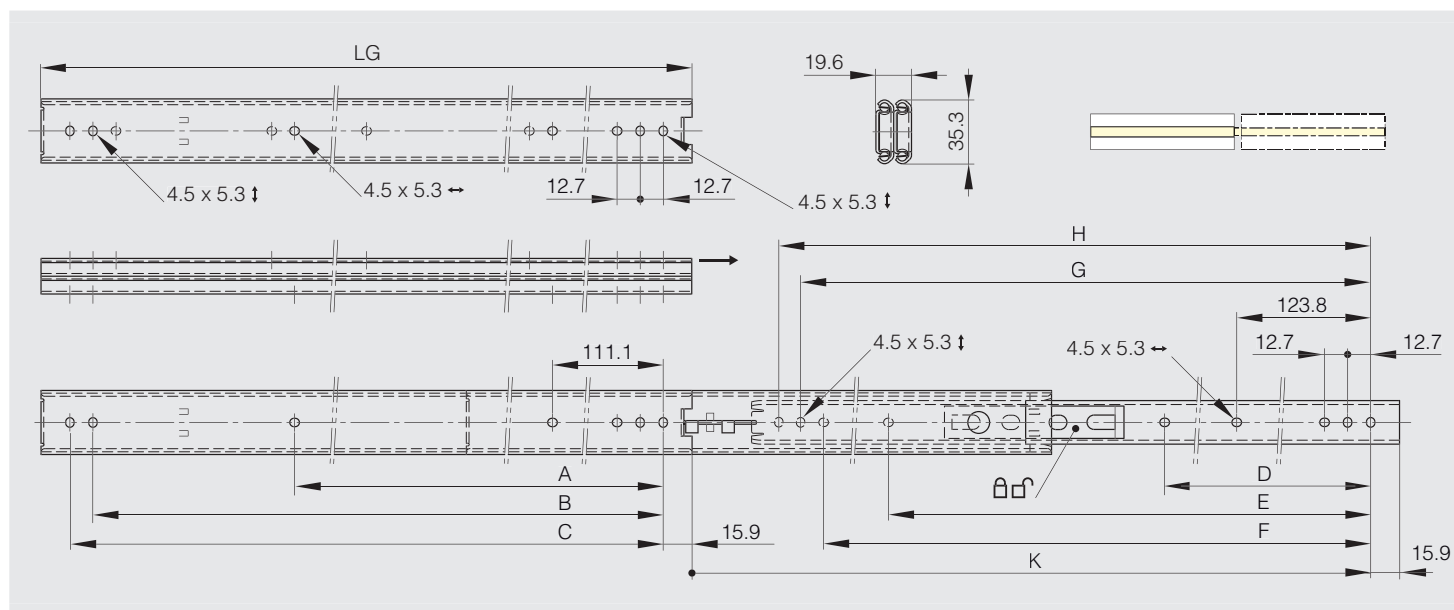



Telescopic slides

Full extension ball-bearing slide (3 pieces), front disconnect and positive stop



LG = slide length.

K = travel length.

CN = load rating (kg/pair).



Part number	Material	Finish	K	LG	A	B	C	D	CN	Weight (g)
21-7-3578	304 stainless steel	raw	327.2	304.8	-	149.2	260.3	273	60	620
21-7-3579	304 stainless steel	raw	378	355.6	-	200	311.1	323.8	59	720
21-7-3555	304 stainless steel	raw	428.4	406.4	-	250.8	361.9	374.6	57	820
21-7-3556	304 stainless steel	raw	479.2	457.2	212.7	301.6	412.7	425.4	56	920
21-7-3557	304 stainless steel	raw	530	508	238.1	352.4	463.5	476.2	54	1025
21-7-3558	304 stainless steel	raw	580.8	558.8	263.5	403.2	514.3	527	51	1125
21-7-3559	304 stainless steel	raw	631.6	609.6	288.9	454	565.1	577.8	49	1225
21-7-3560	304 stainless steel	raw	682.4	660.4	314.3	504.8	615.9	628.6	47	1325
21-7-3561	304 stainless steel	raw	733.2	711.2	339.7	555.6	666.7	679.4	45	1425

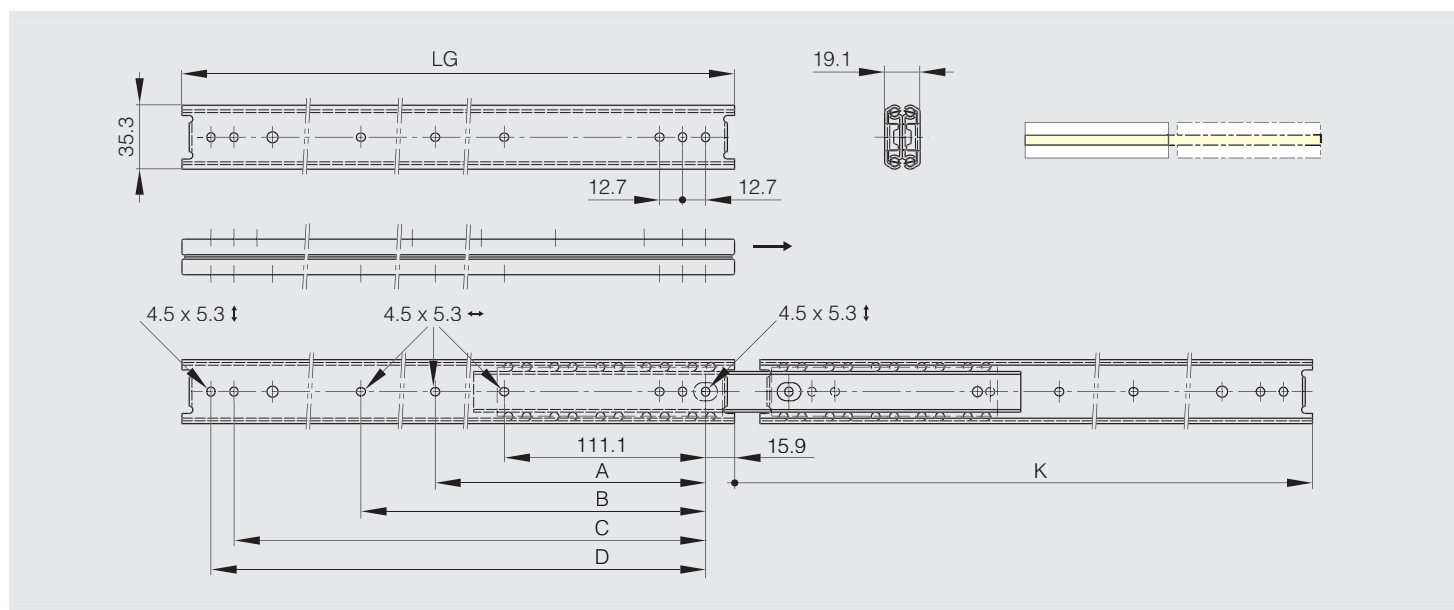



Telescopic slides

Heavy duty, full extension ball-bearing slide (3 pieces), front disconnect and positive stop

LG = slide length.

K = travel length.

CN = load rating (kg/pair).



Part number	Material	Finish	K	LG	A	B	C	CN	Weight (g)
21-7-3548	304 stainless steel	raw	420.6	406.6	-	250.8	374.6	259	2340
21-7-3549	304 stainless steel	raw	471.4	457.4	212.7	301.6	425.4	250	2500
21-7-3550	304 stainless steel	raw	522.2	508.2	238.1	352.4	476.2	241	2840
21-7-3551	304 stainless steel	raw	573	559	263.5	403.2	527	229	3250
21-7-3552	304 stainless steel	raw	623.8	609.8	288.9	454	577.8	216	3500
21-7-3553	304 stainless steel	raw	674.6	660.6	314.3	504.8	628.6	200	3840
21-7-3554	304 stainless steel	raw	725.4	711.4	339.7	555.6	679.4	182	4170

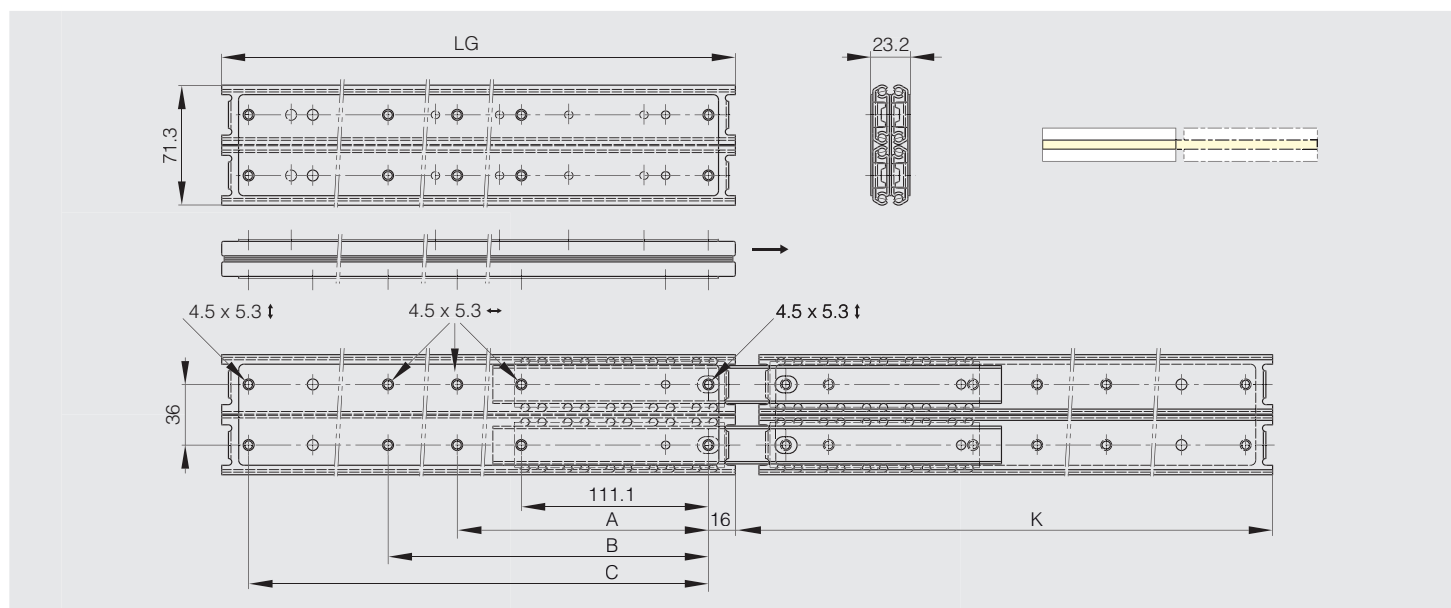



Telescopic slides

Full extension ball-bearing slide (3 pieces), soft-closing



LG = slide length.
 K = travel length.
 CN = load rating (kg/pair).

Soft-close slide.

The drawer can be detached by pushing the lever while pulling the drawer out.

Soft-closes at 20 mm distance from closed position (LG = 300-350 mm) or 36 mm distance from closed position (LG = 400-700 mm).

The maximum width of the drawer is the slide length (LG) + 200 mm.

Sold in pairs.



Part number	Material	Finish	K	LG	A	B	C	D	E	F	G	H	CN	Weight (g)
NEW 21-7-3584	304 stainless steel	raw	265	300	145	-	-	-	-	-	-	174	16	390
NEW 21-7-3585	304 stainless steel	raw	340	350	151	-	-	-	-	-	-	224	16	465
NEW 21-7-3586	304 stainless steel	raw	400	400	167	-	-	-	96	-	-	256	20	535
NEW 21-7-3587	304 stainless steel	raw	450	450	119	215	-	-	128	-	-	306	30	605
NEW 21-7-3588	304 stainless steel	raw	500	500	119	279	-	-	96	160	-	344	35	680
NEW 21-7-3589	304 stainless steel	raw	550	550	119	215	311	-	96	160	-	394	35	730
NEW 21-7-3590	304 stainless steel	raw	600	600	119	247	375	-	128	192	-	444	35	830
NEW 21-7-3591	304 stainless steel	raw	650	650	119	215	311	407	128	224	416	494	35	905
NEW 21-7-3592	304 stainless steel	raw	700	700	119	215	343	471	128	224	480	544	35	980

